

ORANGERIE



Version 2019_1

HANDLEIDING

MOUNTING INSTRUCTIONS

INSTRUCTIONS DE MONTAGE

AUFBAUANLEITUNG

MONTAGE-VEJEDNING

MONTERINGSVEILEDNINGEN

ISTRUZIONI DI MONTAGGIO

PRODUCTINFORMATIE

Geachte klant,

U heeft met de aanschaf van deze aluminium serre een juiste keuze gemaakt waarmee wij u veel plezier wensen.

OPMERKINGEN

Deze handleiding is vooreerst opgesteld om aanwijzingen te geven en standaardoplossingen te tonen. De constructie is – in tegenstelling tot andere producten in ons gamma - GEEN bouw pakket en dient te worden gemonteerd door ervaren monteurs met enige productkennis!

Deze serre heeft het kweken van planten en bloemen tot doel en wordt slechts betreden voor het gebruik door een hiervoor bevoegde persoon. Kleine ondichtheden en condensatiewater in deze constructies zijn dan ook toelaatbaar! Mogelijke zwarte plekken op de profielen zijn eenvoudig met een aluminiumreinigingsmiddel af te nemen, het betreft geen productiefouten. De serre dient geplaatst te worden op een voldoende draagkrachtige betonfundering die voorzien is tot op vaste vorstvrije grond. Het dak van de serre dient in de winter van sneeuw bevrijd te worden, of op een gepaste manier ondersteund worden. De serre moet op een van de wind afgeschermden plaat opgebouwd worden. Tijdens de montage dient men gepaste beschermende kledij te dragen (b.v. veiligheidshandschoenen) om kwetsuren te vermijden. Men dient steeds de lokaal gebruikelijke bouwverordeningen in acht te nemen.

VOLGORDE VAN DE MONTAGE

Opbouw en montagevolgorde is voor alle modellen hetzelfde.

- Uitsorteren van aluminium profielen volgens modelgrootte.
- Montage en opbouw van gehele constructie.
- Horizontaal en waterpas stellen van de constructie.
- Verankering van de constructie.
- Beglazing.

BENODIGD GEREEDSCHAP

Schroefsleutel Nr. 10, schroevendraaier, waterpas, boorapparaat en boortje Ø4.2, metaalzaag, werkhandschoenen, schaar (voor het snijden van rubber).

Constructiewijzigingen onder voorbehoud.

PRODUCT INFORMATION

Dear customer

Thank you for buying a high-quality aluminium greenhouse.

REMARKS

This manual is intended to be a guidance, showing all kind of standard-solutions that can be useful during mounting.

Unlike the other models in our range, this type of house is NOT designed to be a build-it-yourself-kit, it has to be mounted by experienced builders who are familiar with these products and their assembly!

This greenhouse is designed for cultivation of plants/flowers. Therefore leakage, water drops and condensation inside the building are allowed. The building may only be entered by competent persons during cultivation or maintenance. Aluminium profiles that are not painted may show black stains, these stains are not a production error: they can be easily removed with a aluminium cleaner available at every good drugstore. The rubber strips have been treated with oil/silicone on the interior to facilitate the assembly. The building should be mounted on a solid concrete foundation deep enough to get a solid and frost-free ground. During winter the roof has to be cleared of snow or supported in a suitable way. The greenhouse should be built in a location protected from strong winds. Protective gear (such as protective gloves) should be used during mounting in order to avoid injuries. One should at all times pay attention to the local building regulations.

ASSEMBLY ORDER

The assembly procedure is the same for all our greenhouses.

- Sorting of the profiles according the model.
- Mounting of the complete aluminium construction.
- Leveling of the construction using a waterlevel.
- Securing the building to the ground
- Glazing.

REQUIRED TOOLS

Socket wrench nr. 10 or spanner nr. 10, water-level, screwdriver, drilling machine + drill 4.2 mm, scissors (to cut the rubber).

We reserve the right to change the construction without prior notice!

INFORMATION SUR LE PRODUIT

Cher client,

Nous vous félicitons à l'achat de la serre en aluminium.

REMARQUES

Ce manuel vous explique plusieurs détails standard qui peuvent être intéressants à consulter pendant le montage de la serre. Par contre, ce modèle de serre n'est PAS un kit de montage ! Ce modèle doit être monté par une équipe professionnelle qui est connue avec le système de profilés.

La serre est une verrière pour cultiver des plantes et des légumes: des petites fuites et de l'eau de condensation sont autorisées.

Les couvercles noirs en caoutchouc sont, à l'intérieur, traités à l'huile. Ceci garantit un montage simple et rapide. Si les profilés en alu montrent des taches noires, il ne s'agit pas d'un défaut de production. Ces taches peuvent facilement être enlevées au moyen de nettoyeurs pour aluminium, qui sont disponibles sur le marché. Une fondation à l'abri du gel et portance suffisante est nécessaire. Pendant l'hiver il faut enlever la neige de la toiture ou étancher le toit. Il faut construire la serre dans un endroit protégé du vent. Afin d'éviter des blessures lors de la montage, il faut porter des vêtements de travail, qui pourront vous protéger (p.ex. des gants de sécurité). En tout cas il faut respecter les règles urbanistiques locales.

DÉROULEMENT DU MONTAGE

L'ordre de montage est identique pour tous les modèles:

- Triage des profilés en alu en fonction des dimensions du modèle.
- Assemblage des profilés et montage de la structure.
- Alignement vertical et horizontal de la construction.
- Pose du vitrage.

OUTILLAGE NÉCESSAIRE

Clef N° 10, tournevis, niveau à bulle, perceuse et foret Ø4.2mm, scie à métaux, gants de travail, ciseaux (pour la mise à longueur du joint en caoutchouc).

Sous réserve de tout changement.

PRODUKT INFORMATION

Sehr geehrter Kunde,

Wir möchten Ihnen zum Kauf des Gewächshauses gratulieren.

ANMERKUNGEN

Die Aufbauanleitung bezieht sich zunächst auf Details und Abbildungen, es sind Beispielen und Hinweisen für die Montage des Gewächshauses. In gegen unsere Standardmodellen ist diese Konstruktion KEIN selbstbau-Paket aber nur zu montieren durch professionelle Montageteams, bekannt mit das Profilsystem und der Montageablauf!

Das Gewächshaus sollte in einer windgeschützten Lage montiert werden. Während des Winters sollte das Dach von Schnee befreit werden oder durch geeignete Maßnahmen abgestützt werden! Alle Konstruktionen sind nach baurechtlichen Vorschriften am Boden zu befestigen. In jedem Fall muss ein frostfreies Betonfundament vorhanden sein. Unlackierte Alu-Profile können schwarze Flecken aufweisen, hierbei handelt es sich nicht um einen Produktionsfehler. Mit einem handelsüblichen Alu-Reiniger lassen sich diese weitestgehend entfernen. Die Gewächshäuser dienen der Kultur von Pflanzen und werden durch gärtnerische tätige oder entsprechend autorisierte Personen oder nur in deren Begleitung betreten. Kleine Undichtigkeiten, Wassertropfen und Kondensat sind zulässig. Das mitgelieferte Dichtungsgummi ist an der Innenseite mit Talg behandelt, was zu einer schnelleren und einfacheren Montage beiträgt. Bei der Montage muss man Schutzausrüstung tragen z.B. Sicherheitshandschuhe, um Verletzungen zu vermeiden. In jedem Fall muss die landesübliche Bauordnung beachtet werden!

MONTAGEABLAUF

Der Montagevorgang ist bei allen Modellen gleich:

- Auslegen der Alu-Profile gemäß Modellgröße.
- Aufbau der Alu-Konstruktion.
- Horizontale und vertikale Ausrichtung der Konstruktion.
- Verankerung der Konstruktion.
- Verglasung.

BENÖTIGTES WERKZEUG

Schraubenschlüssel Nr. 10, Schraubenzieher, Wasserwaage, Bohrmaschine und Bohrer (4.2 mm) Metallsäge, Schere (für das Zuschneiden der Gummidichtung).

Konstruktionsänderungen behalten wir uns vor.

Carrousel / Pagode

Funderingsplan – Plan de Fondation – Fundamentenplan – Foundation drawing

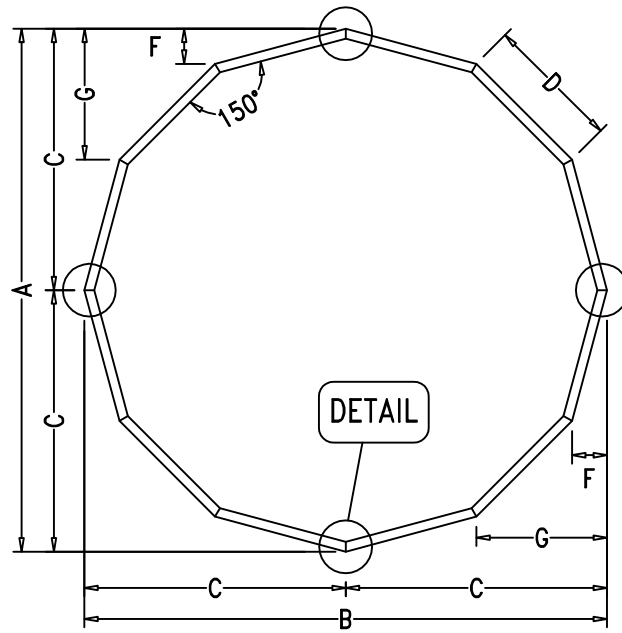
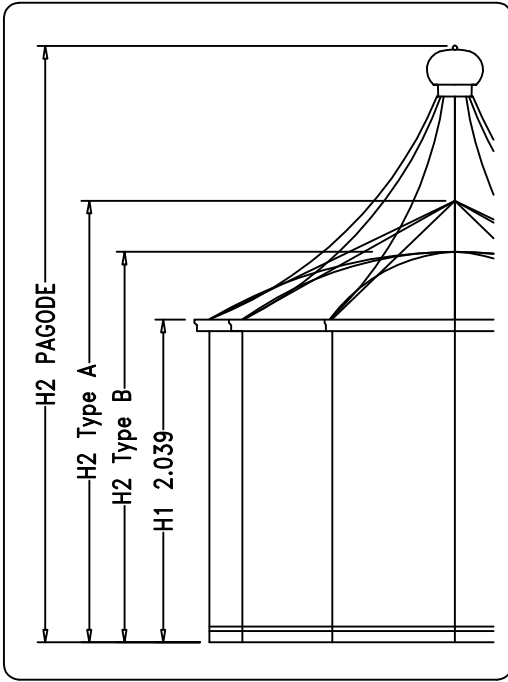

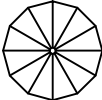
Model	ø3.100 (=A)	ø3.776 (=A)
Carrousel A	C = 1.542	C = 1.880
Carrousel B	D=802 (D=794)	D=977 (D=969)
Pagode	F = 205 G = 773	F = 253 G = 941
	B = 3.100 A = B	B = 3.776 A = B

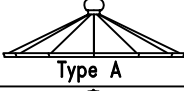
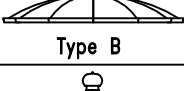
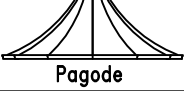
Model	DIA (A)	H1	H2 (max)
 Type A	3.100 3.776	2.039 2.039	3.070 3.110
 Type B	3.100 3.776	2.039 2.039	2.766 3.002
 Pagode	3.100 3.776	2.039 2.039	3.765 4.067

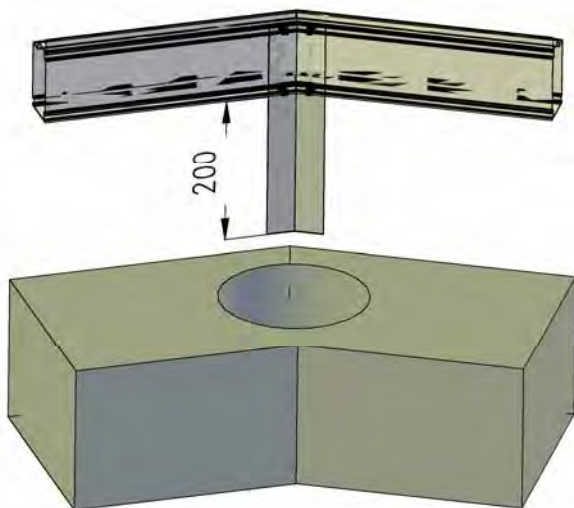
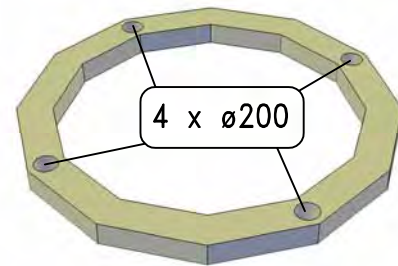

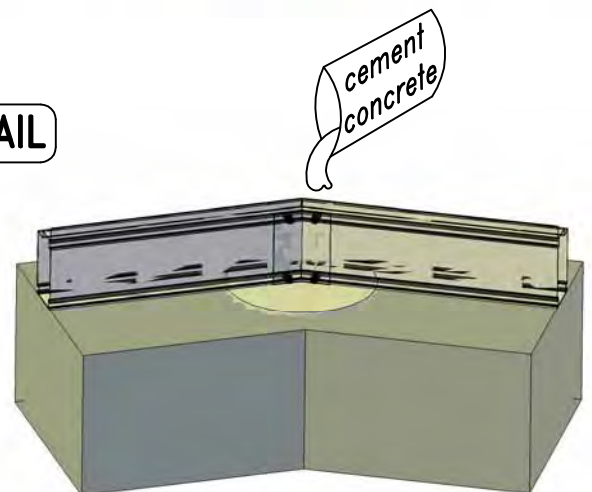

DETAIL

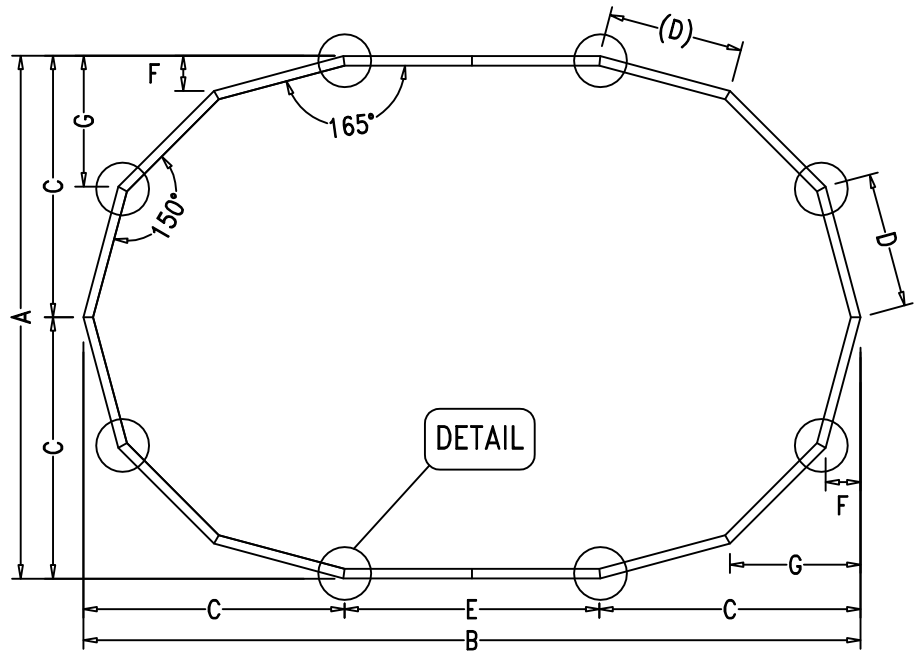
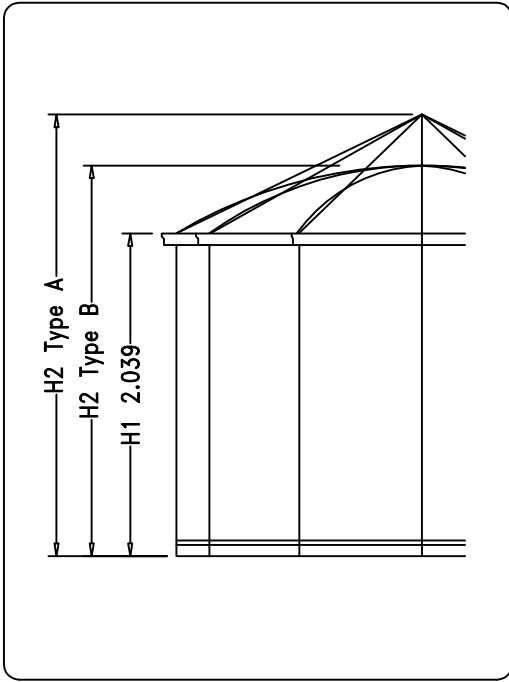

Funderingsplan – Plan de Fondation – Fundamentenplan – Foundation drawing

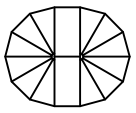
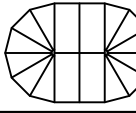
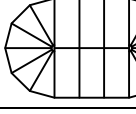
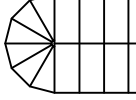

Model	ø3.100 (=A)	ø3.776 (=A)
Carrousel A	C = 1.542	C = 1.880
Carrousel B	D=802 (D=794)	D=977 (D=969)
	F = 205	F = 253
	G = 773	G = 941
 1xE	B = 3.871 E = 786	B = 4.547 E = 786
 2xE	B = 4.608 E = 1.524	B = 5.285 E = 1.524
 3xE	B = 5.346 E = 2.262	B = 6.023 E = 2.262
 4xE	B = 6.085 E = 3.000	B = 6.761 E = 3.000

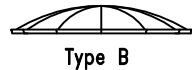
Model	DIA (A)	H1	H2 (max)
 Type A	3.100 3.776	2.039 2.039	2.770 2.910
 Type B	3.100 3.776	2.039 2.039	2.466 2.702

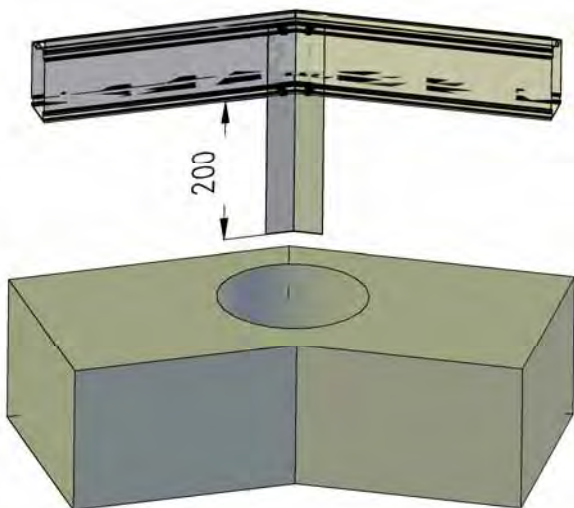
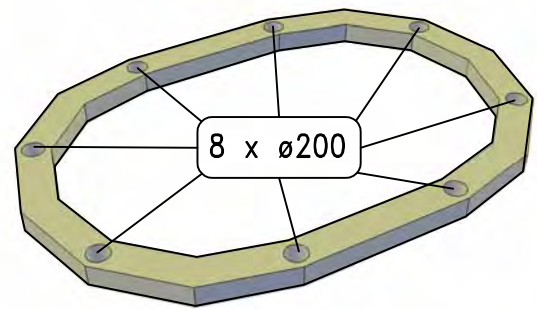

DETAIL

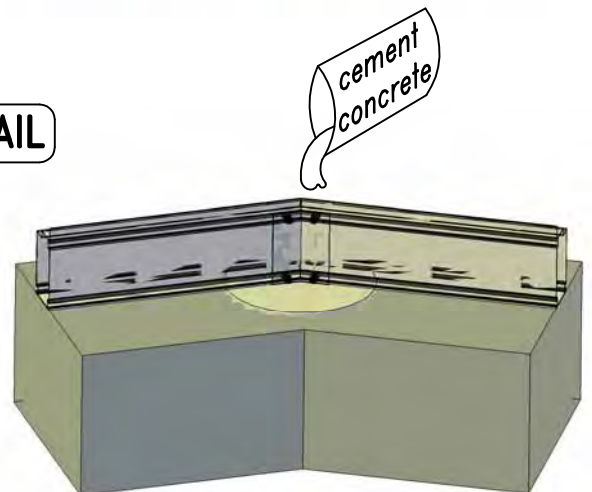

Funderingsplan – Plan de Fondation – Fundamentenplan – Foundation drawing

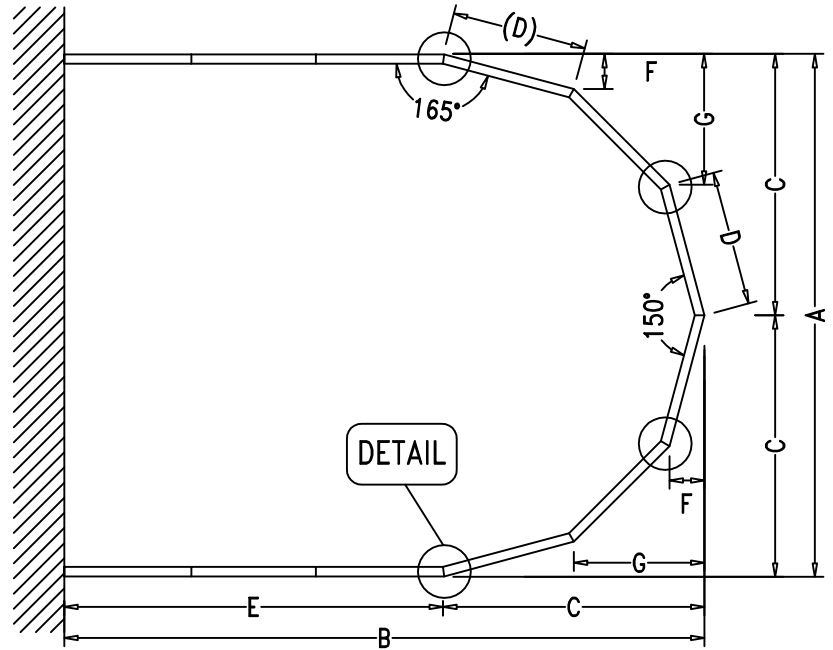
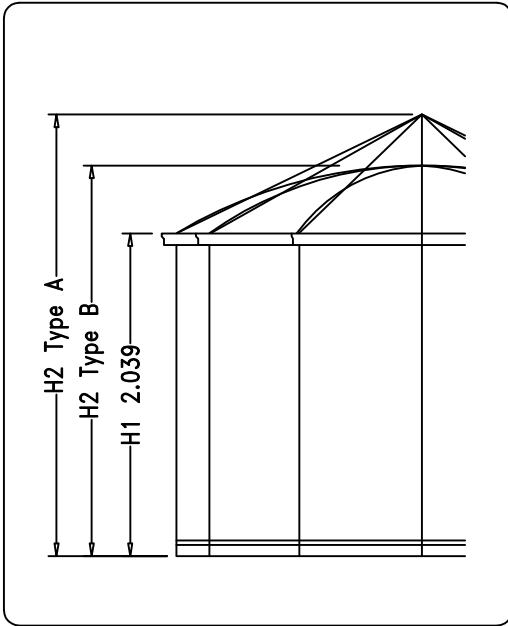

Model	ø3.100 (=A)	ø3.776 (=A)
Carrousel A Carrousel B	C = 1.542 D=802 (D=794) F = 205 G = 773	C = 1.880 D=977 (D=969) F = 253 G = 941
	B = 1.584 E = 42	B = 1.922 E = 42
	B = 2.322 E = 780	B = 2.660 E = 780
	B = 3.060 E = 1.518	B = 3.398 E = 1.518
	B = 3.798 E = 2.256	B = 4.136 E = 2.256
	B = 4.536 E = 2.994	B = 4.874 E = 2.994

Model	DIA (A)	H1	H2 (max)
	3.100 3.776	2.039	2.770 2.910
	3.100 3.776	2.039	2.466 2.702

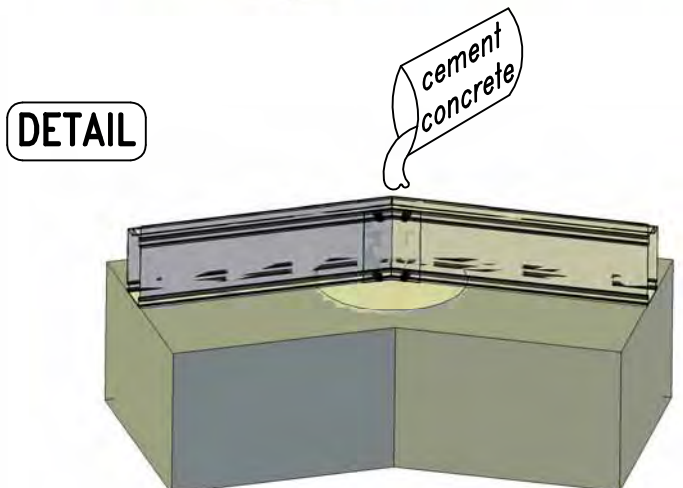
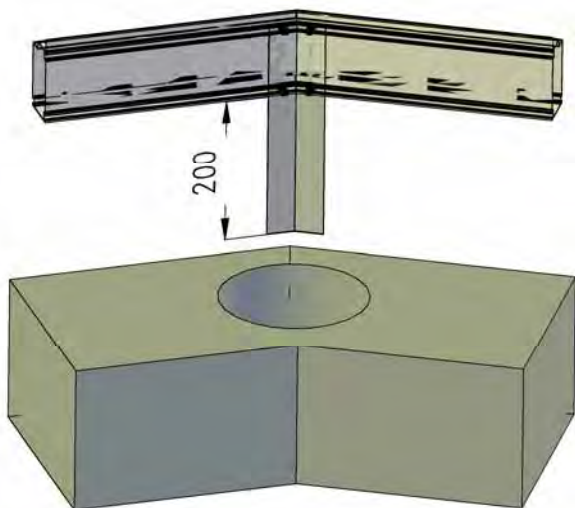
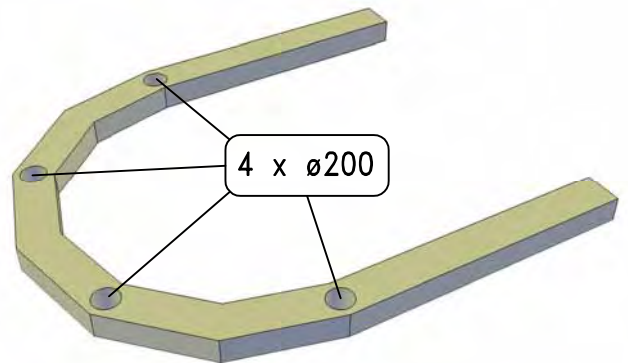

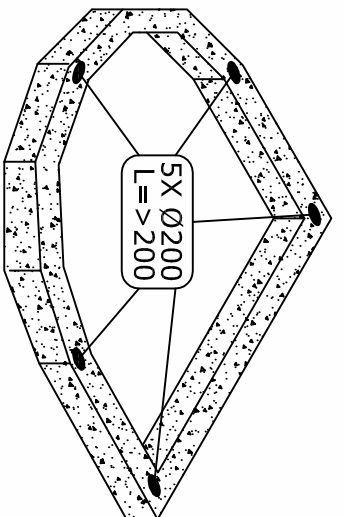
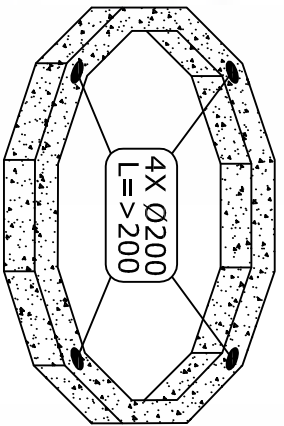
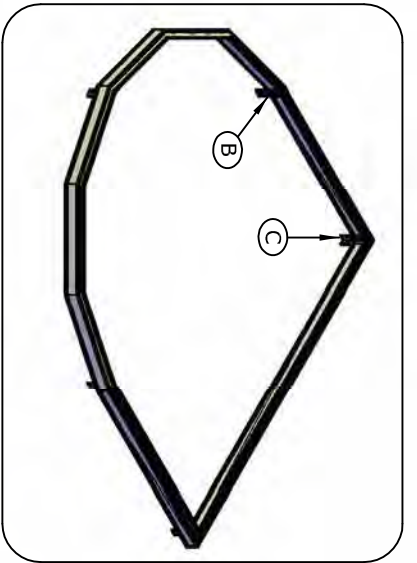
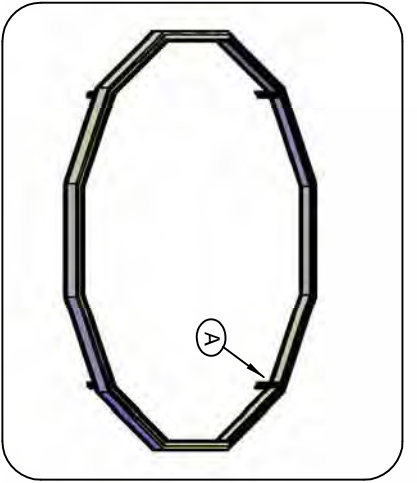

A

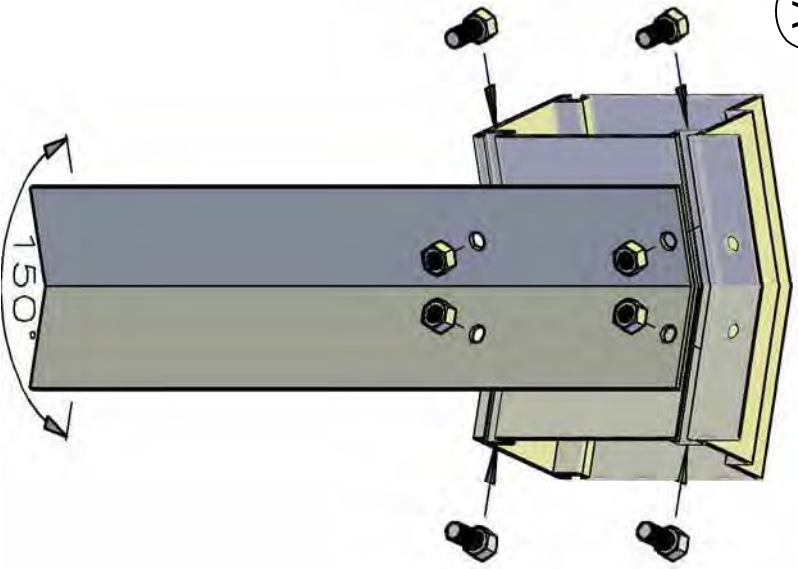

B

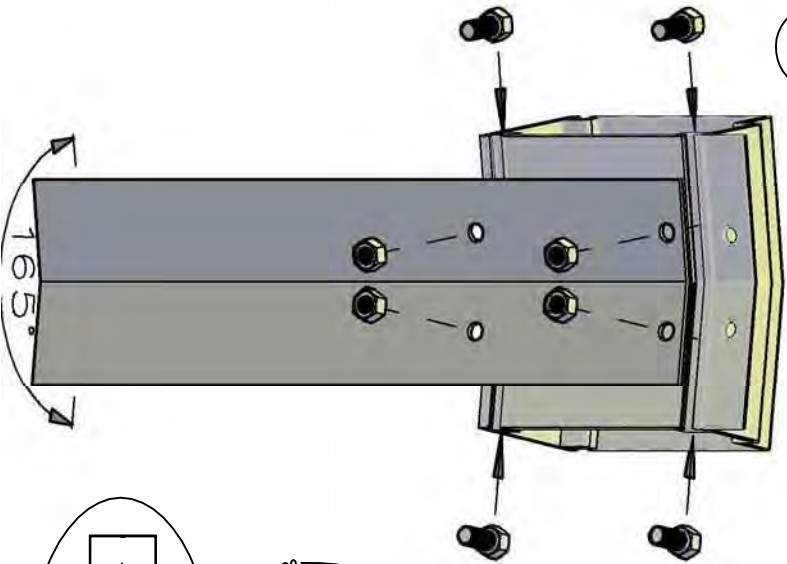

C

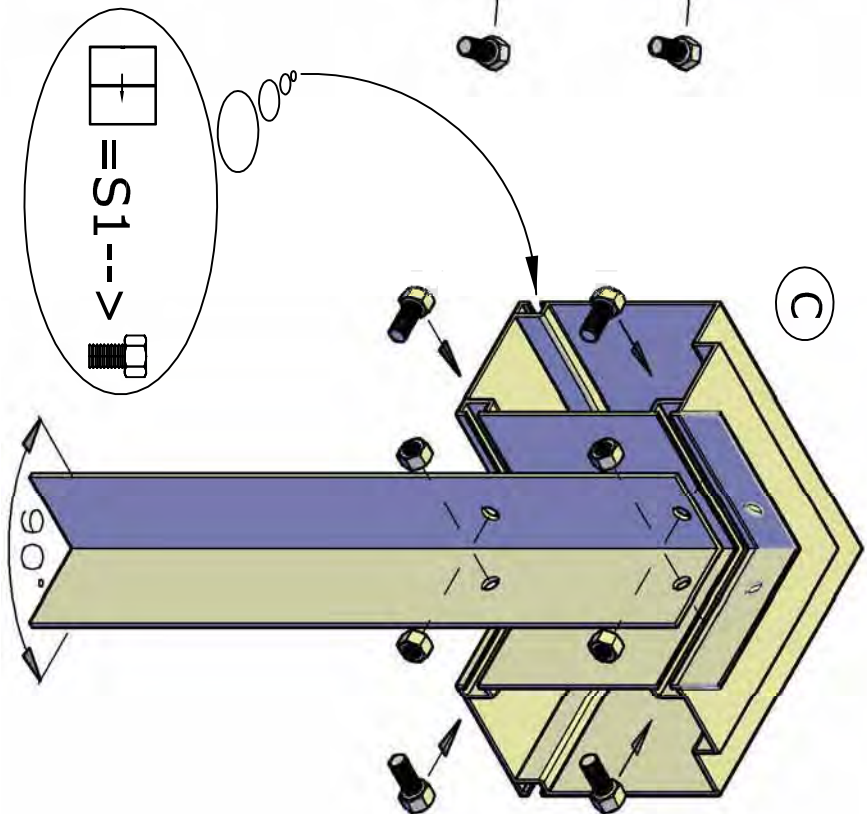

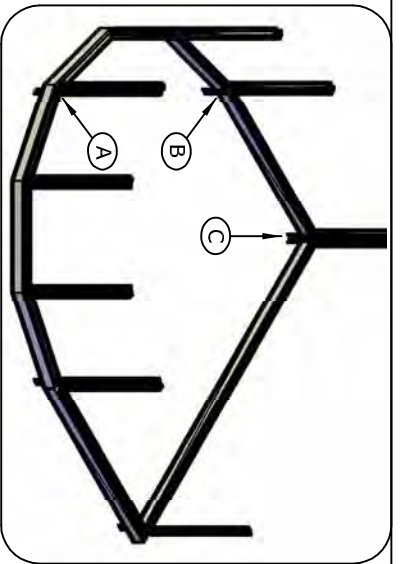

A

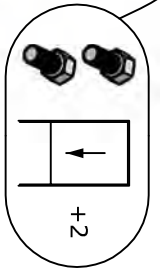
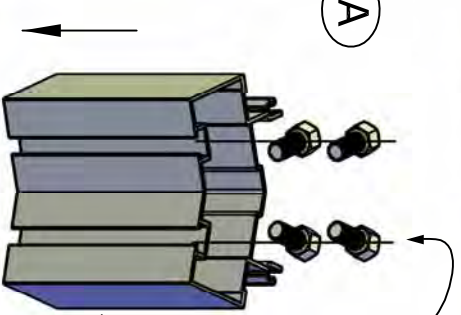

B

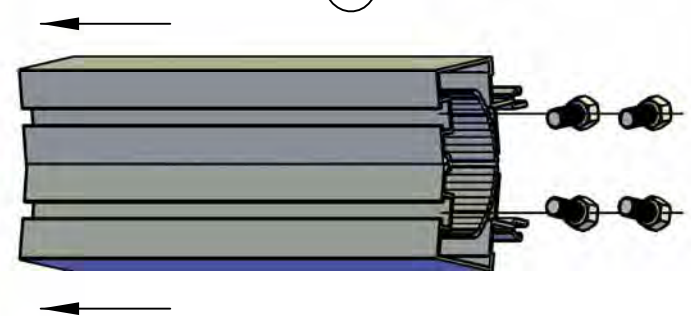

C

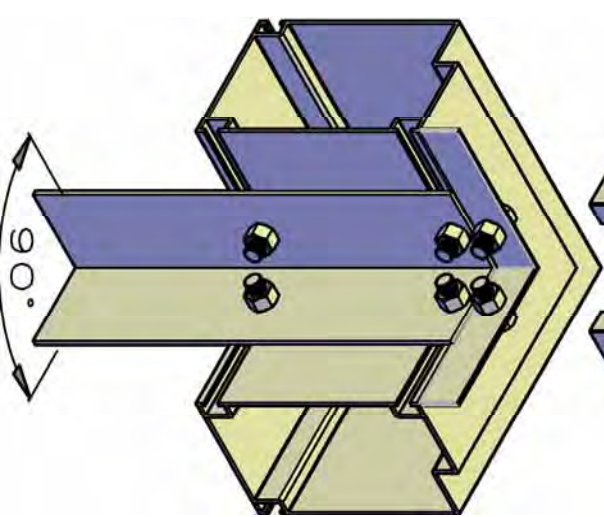
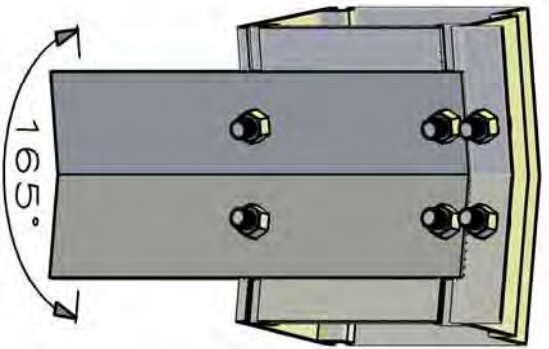
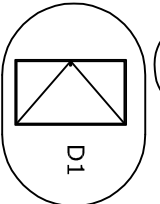
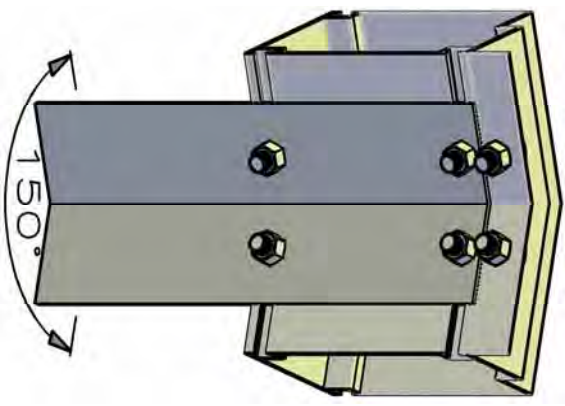
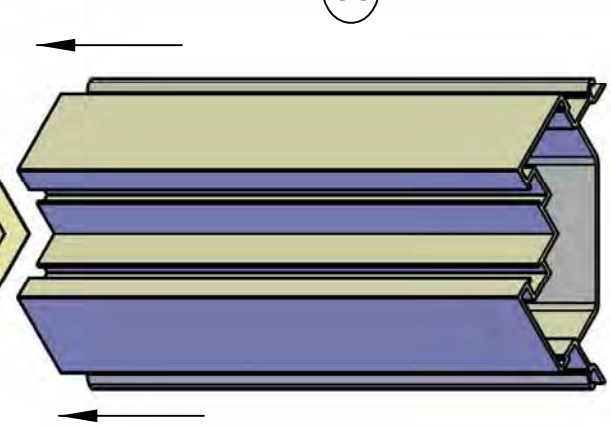

C2

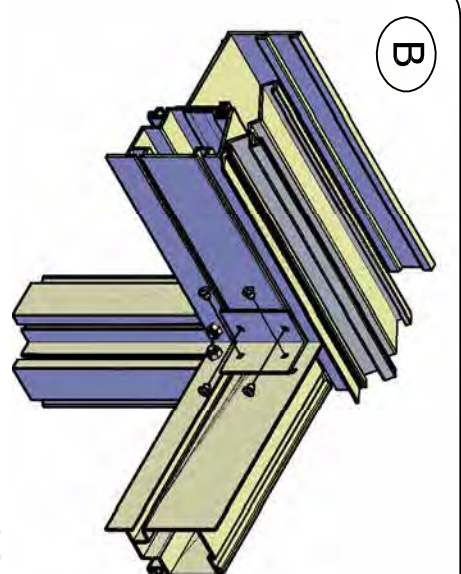
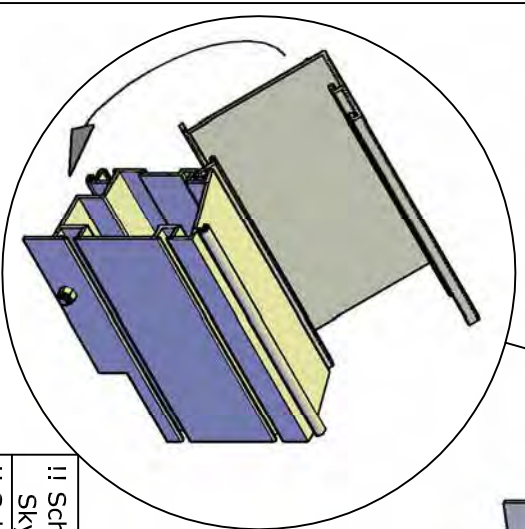
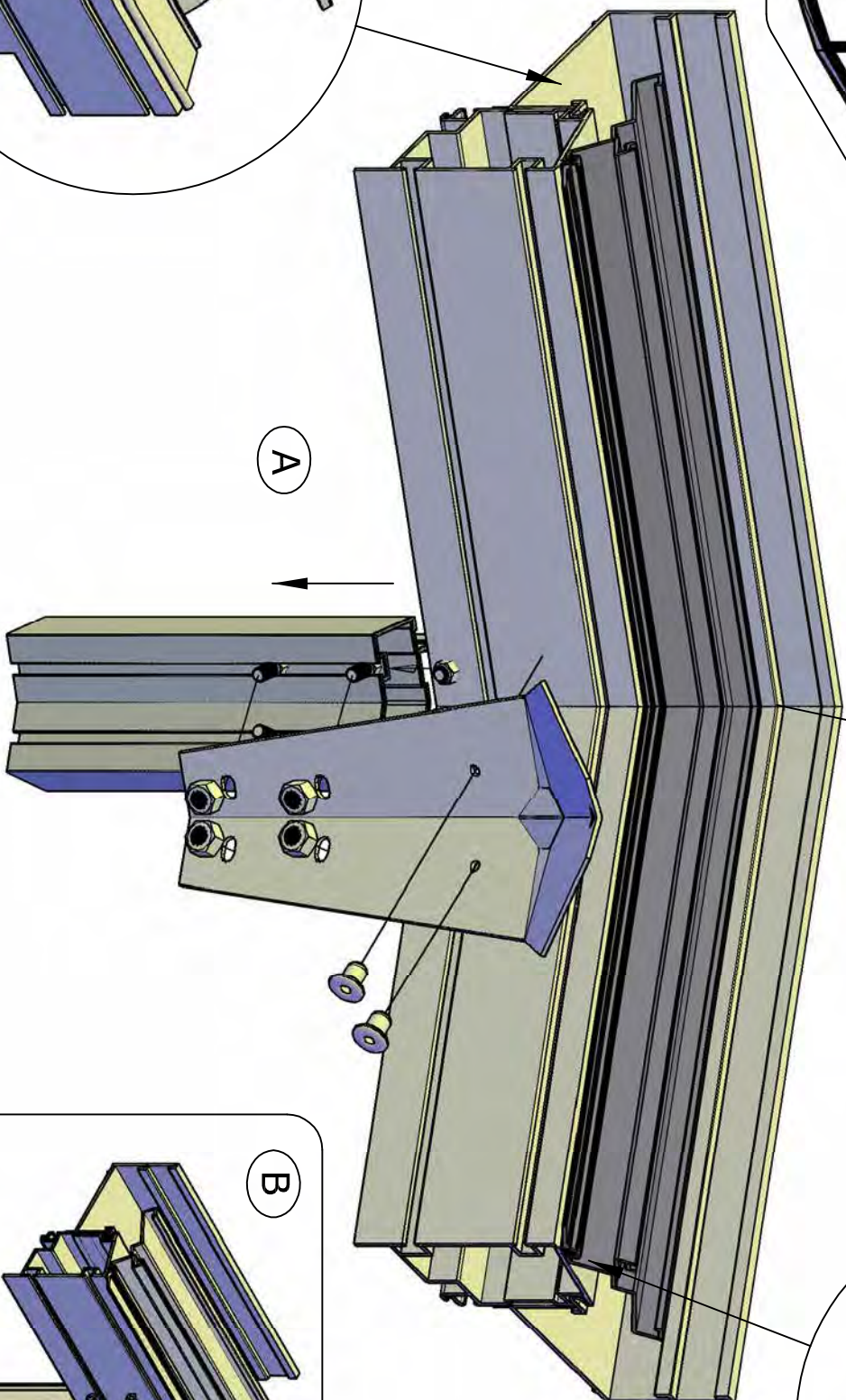
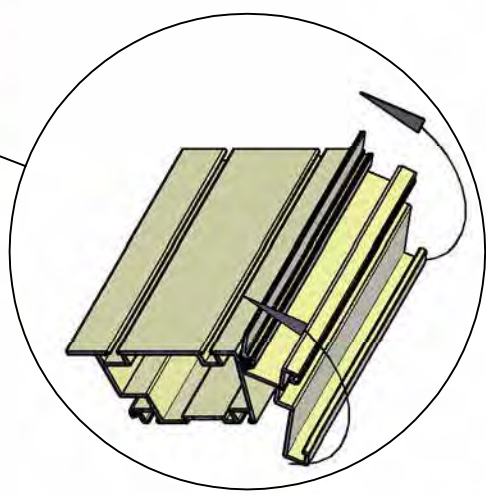
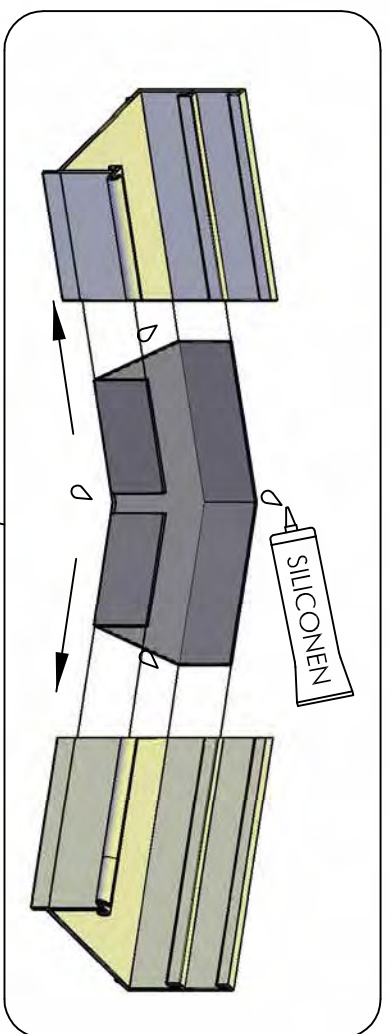
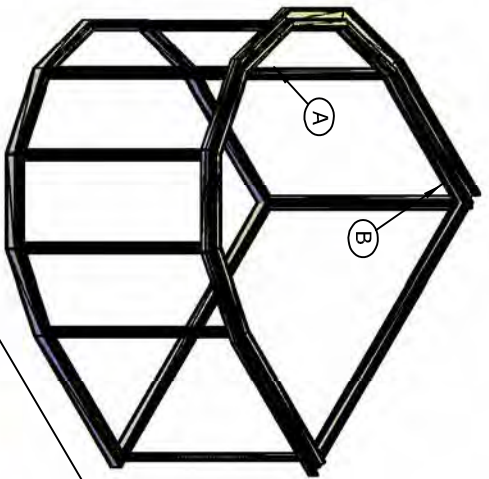

ii Schuifdeur-Porte Couliissante-Schiebetür-Sliding door =S1
 ii Skydedør-Skyvedør-Skugvæv-Porta scorrevole
 ii Schuifraam-Fenêtre Couliissante-Schiebefenster-Sliding window =SR1
 ii Skydevindue-Skyvefönster-Skugvindue-Finestra scorrevole

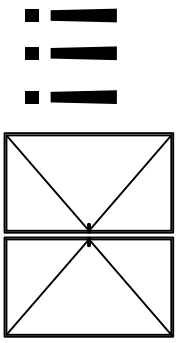

Dubbele draaideur in ronding!
Döppel Drehtür in Rundung!
Double turning door in rounding!
Double porte tournante dans l'arrondi!

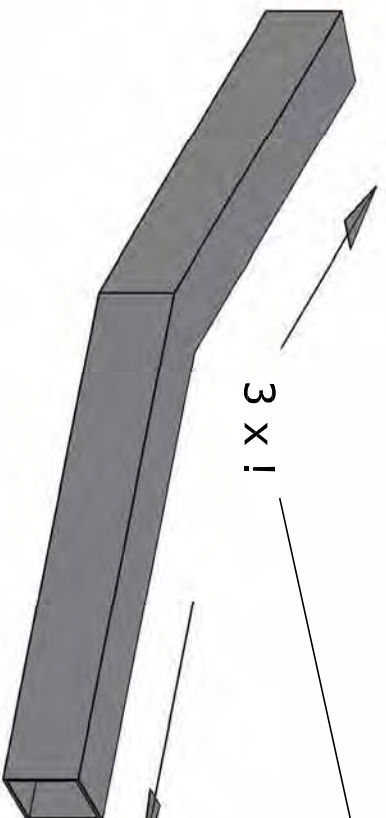
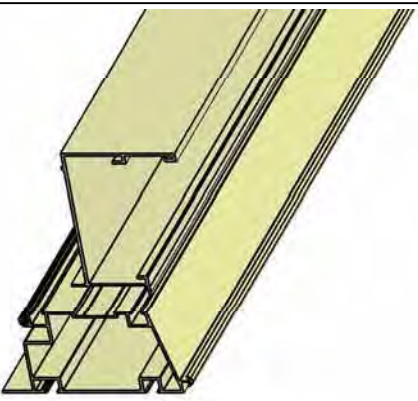

3 x 1

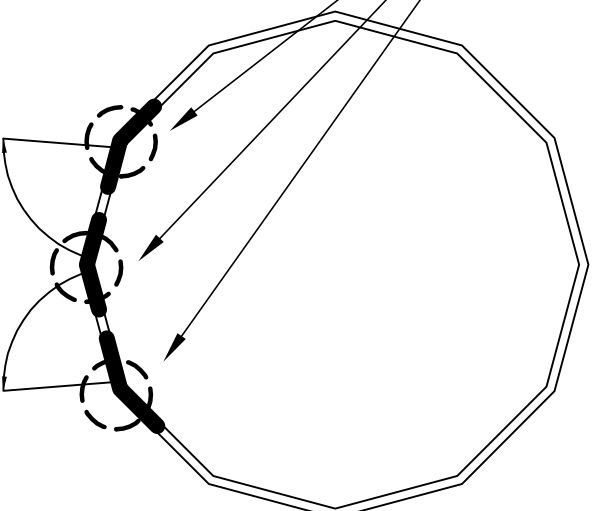
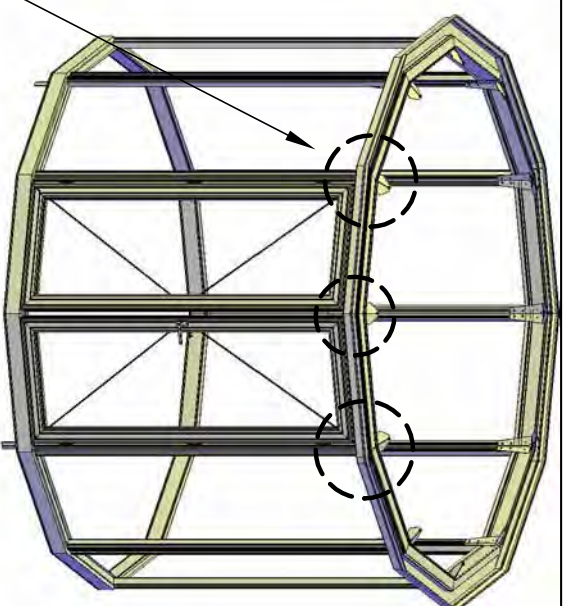

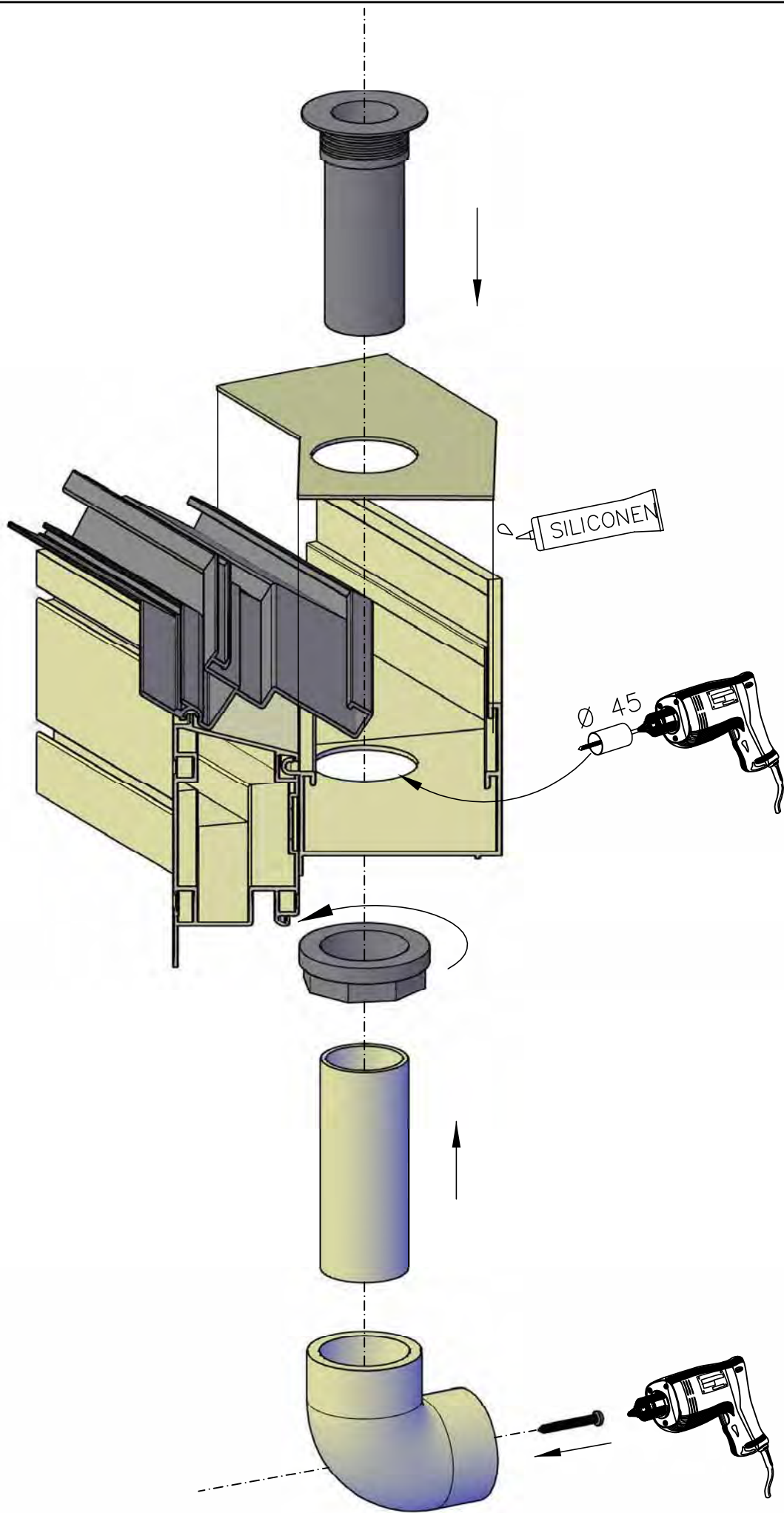

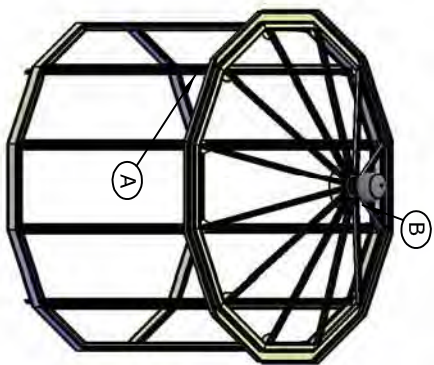

A

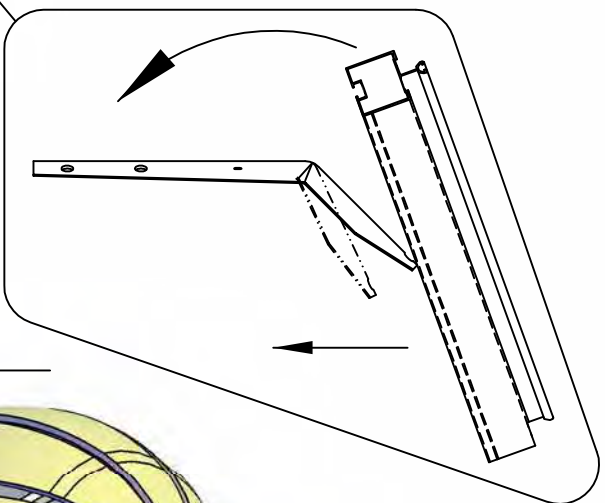
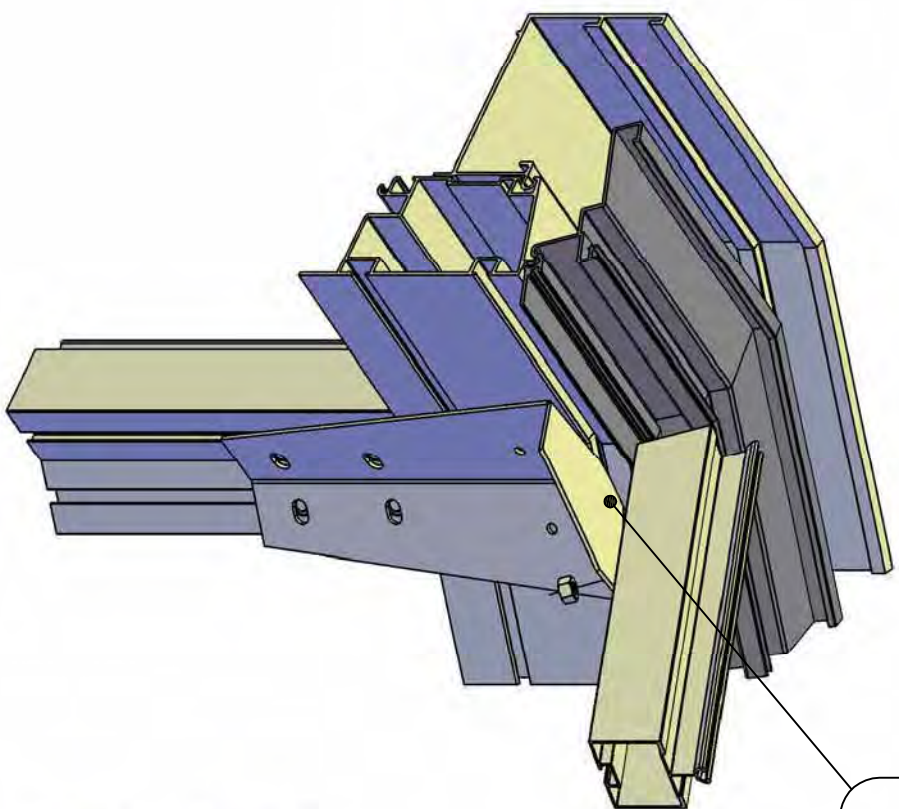

B

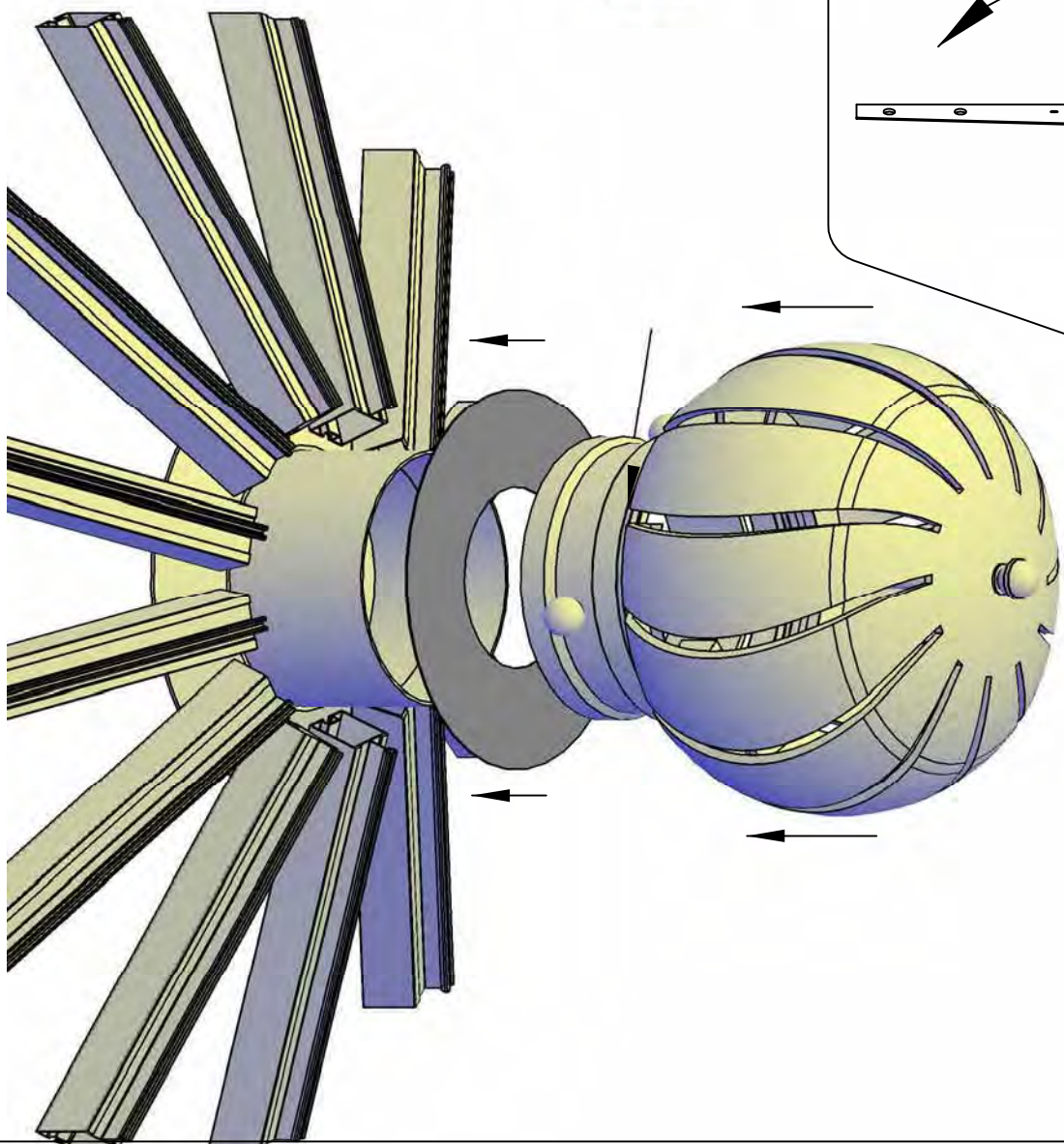

C5

PAGODE

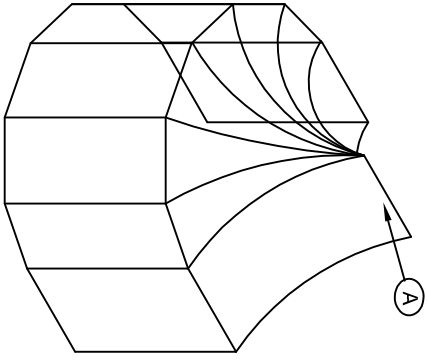

TYPE A

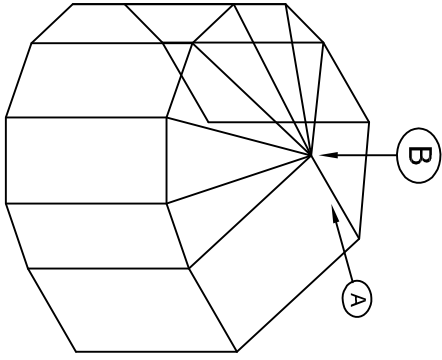

TYPE B

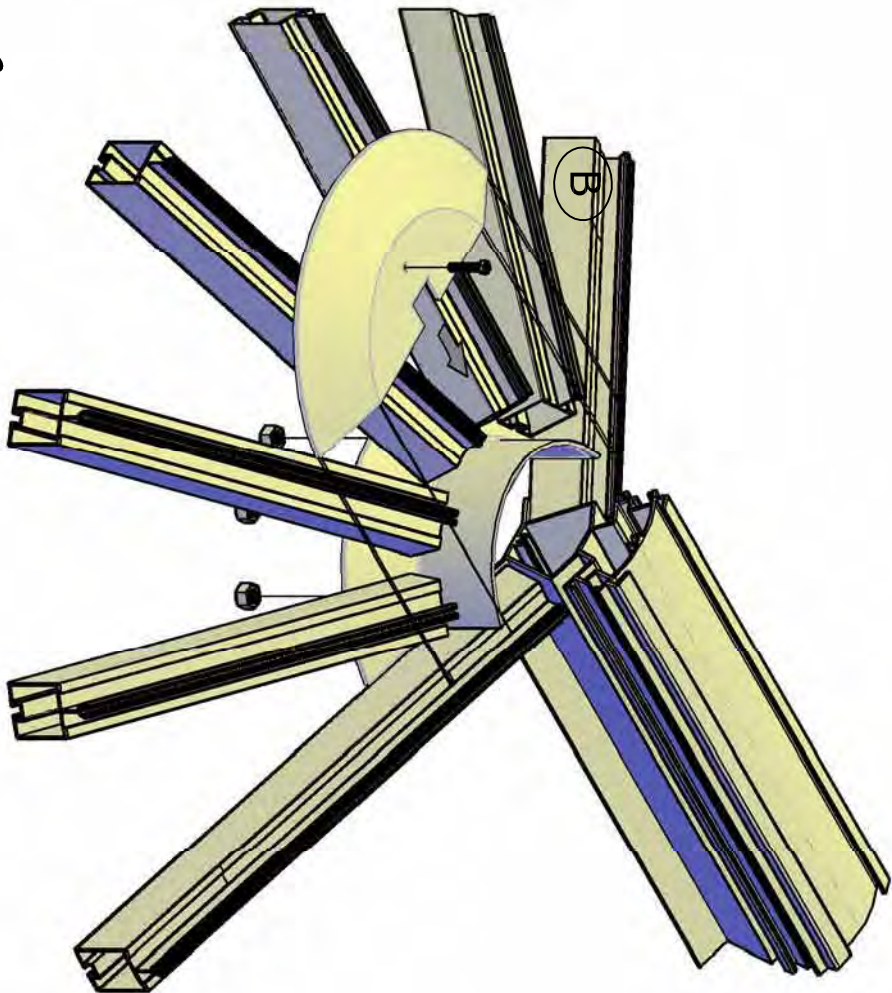
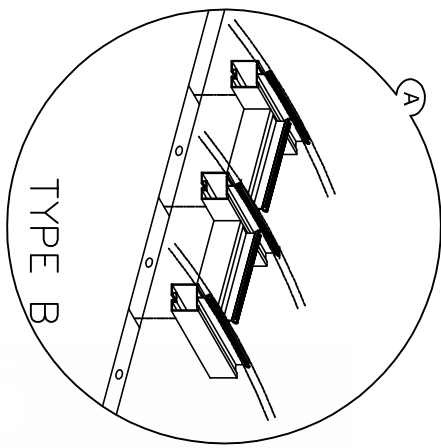
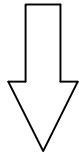
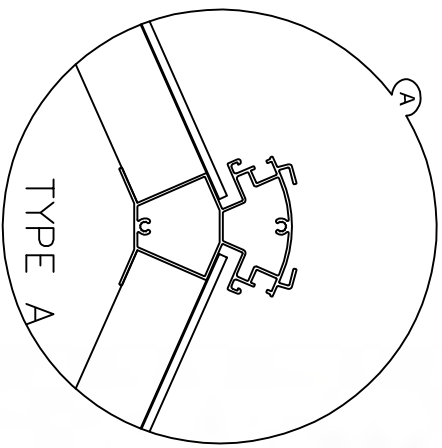
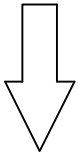
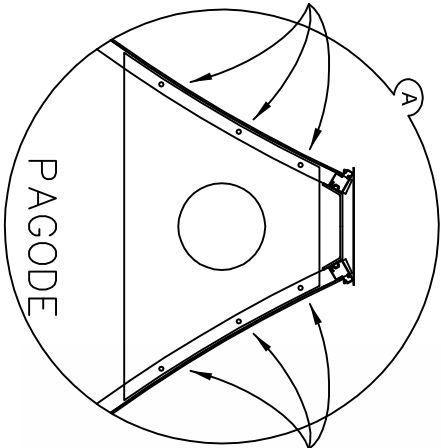
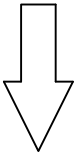
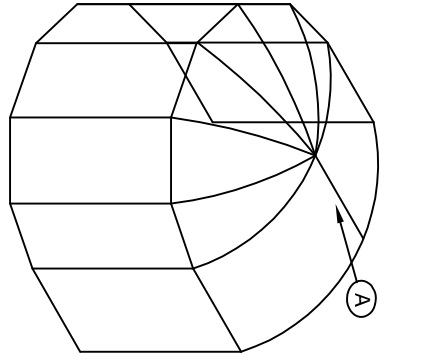

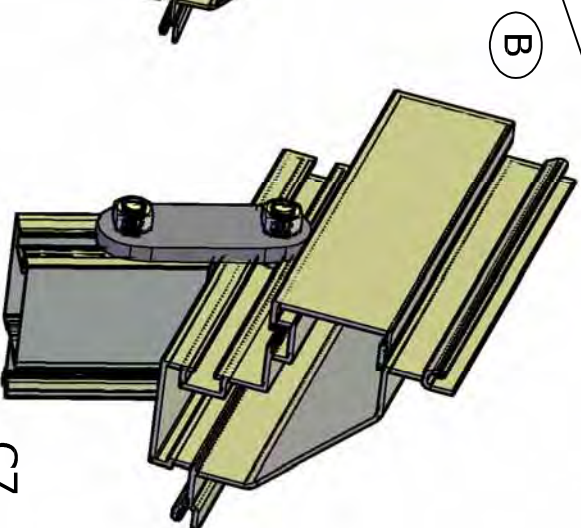
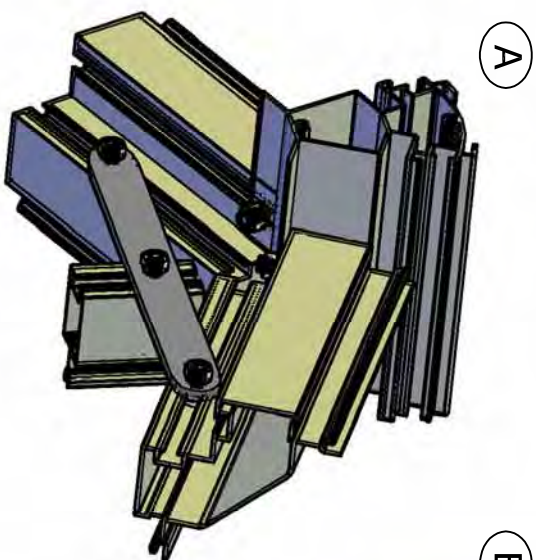
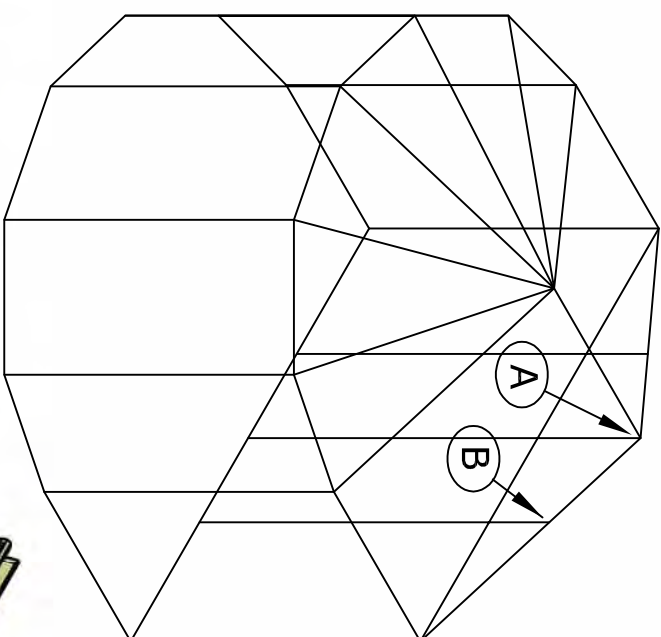
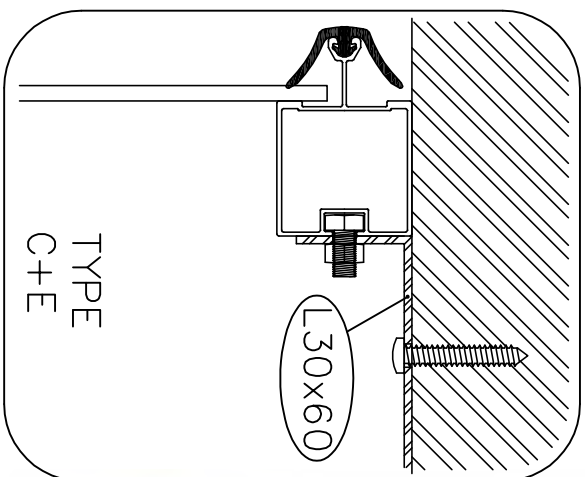
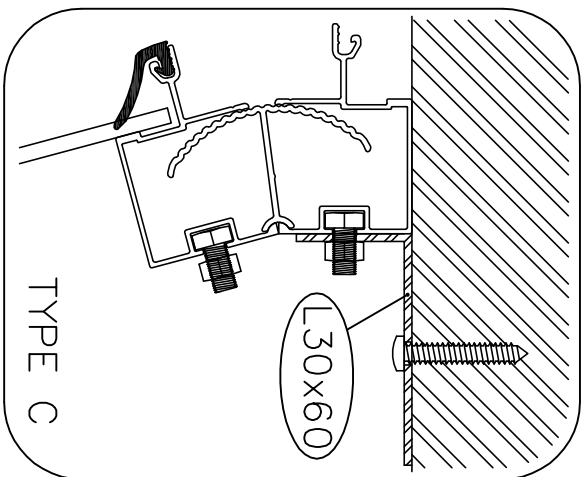
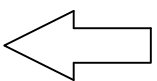
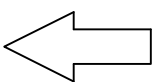
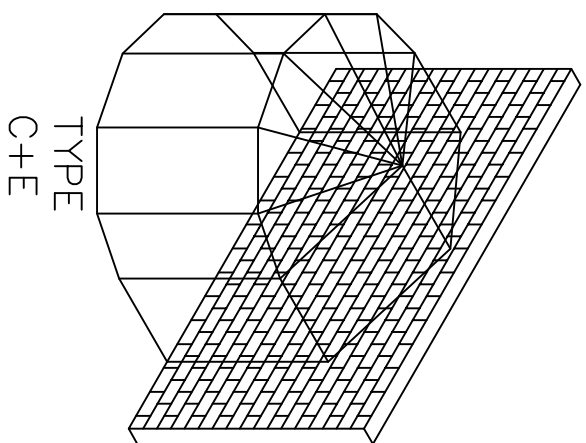
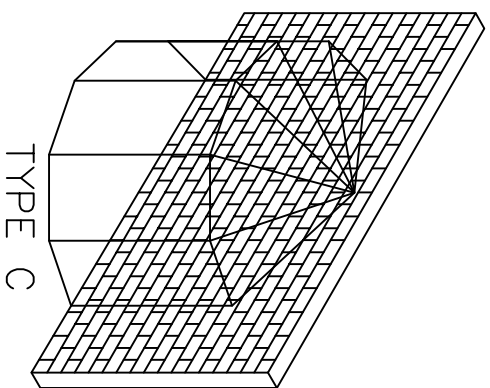

C7

Helios > 5m40 / Carrousel / Pagode / Orangerie

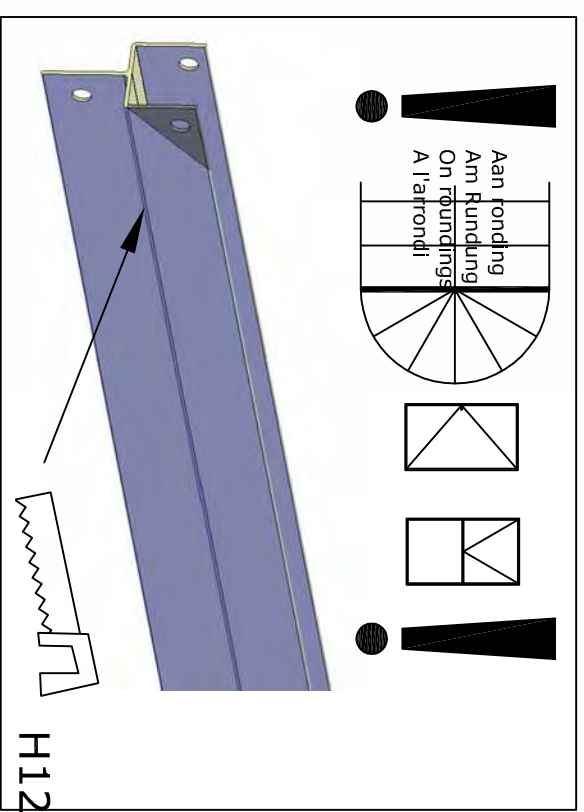
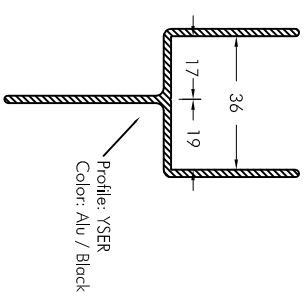
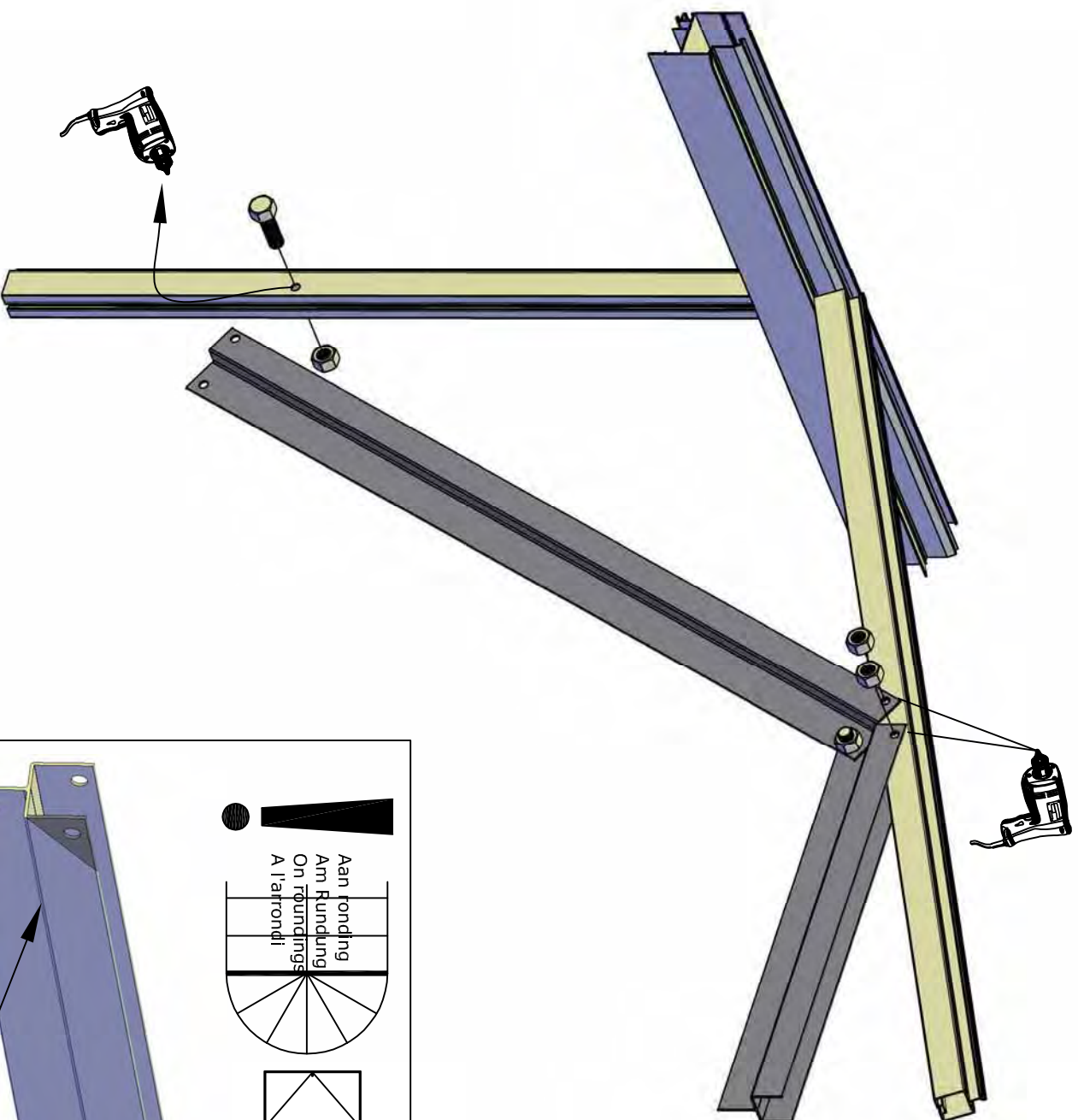
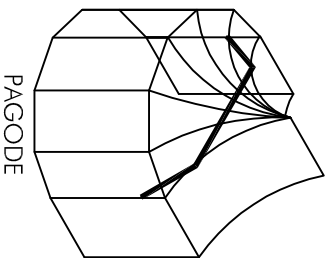
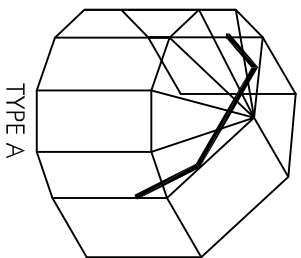
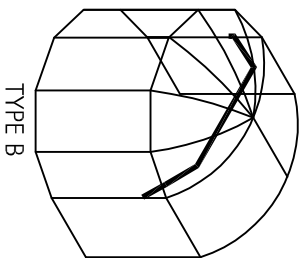
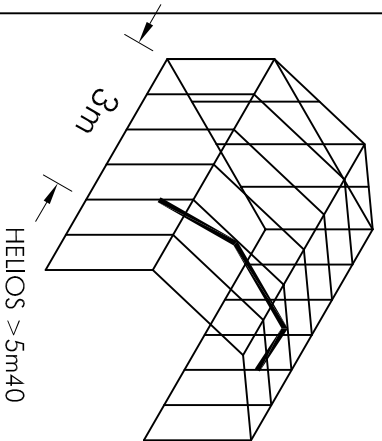

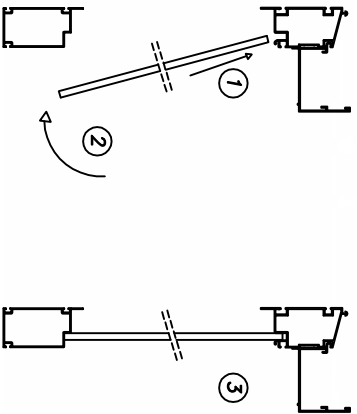
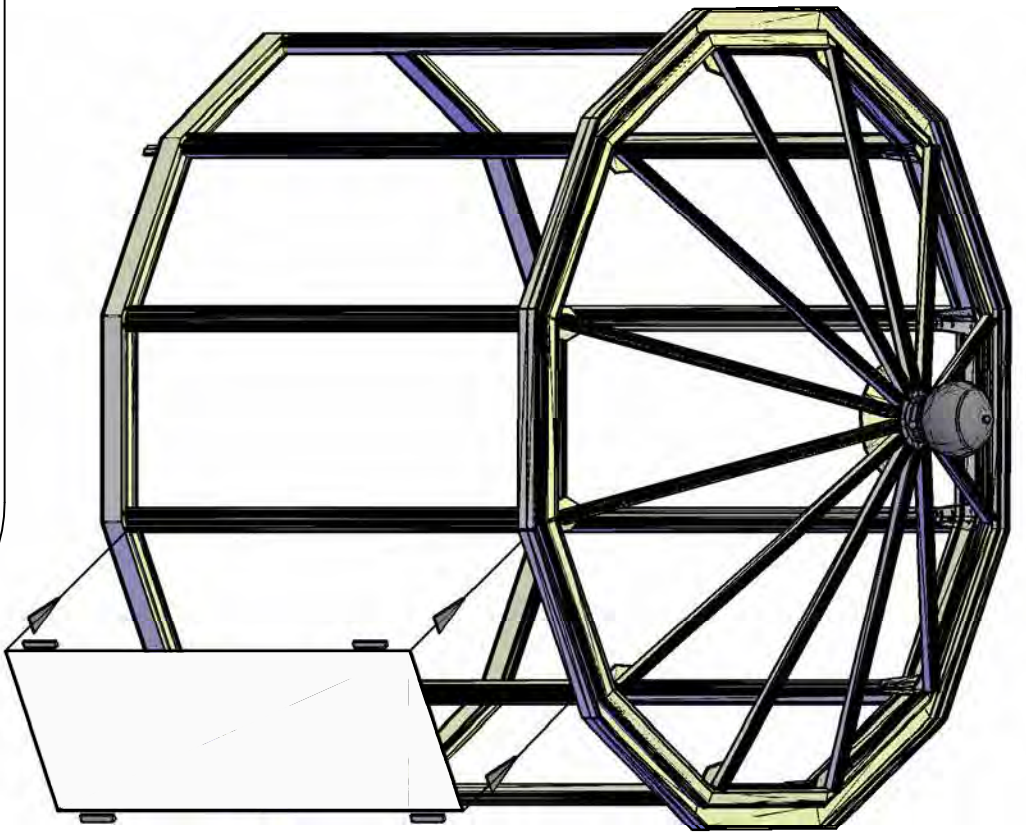

!!! K-glas: ● =Inside / Innerseite / Intérieur

SILICONEN

100 mm

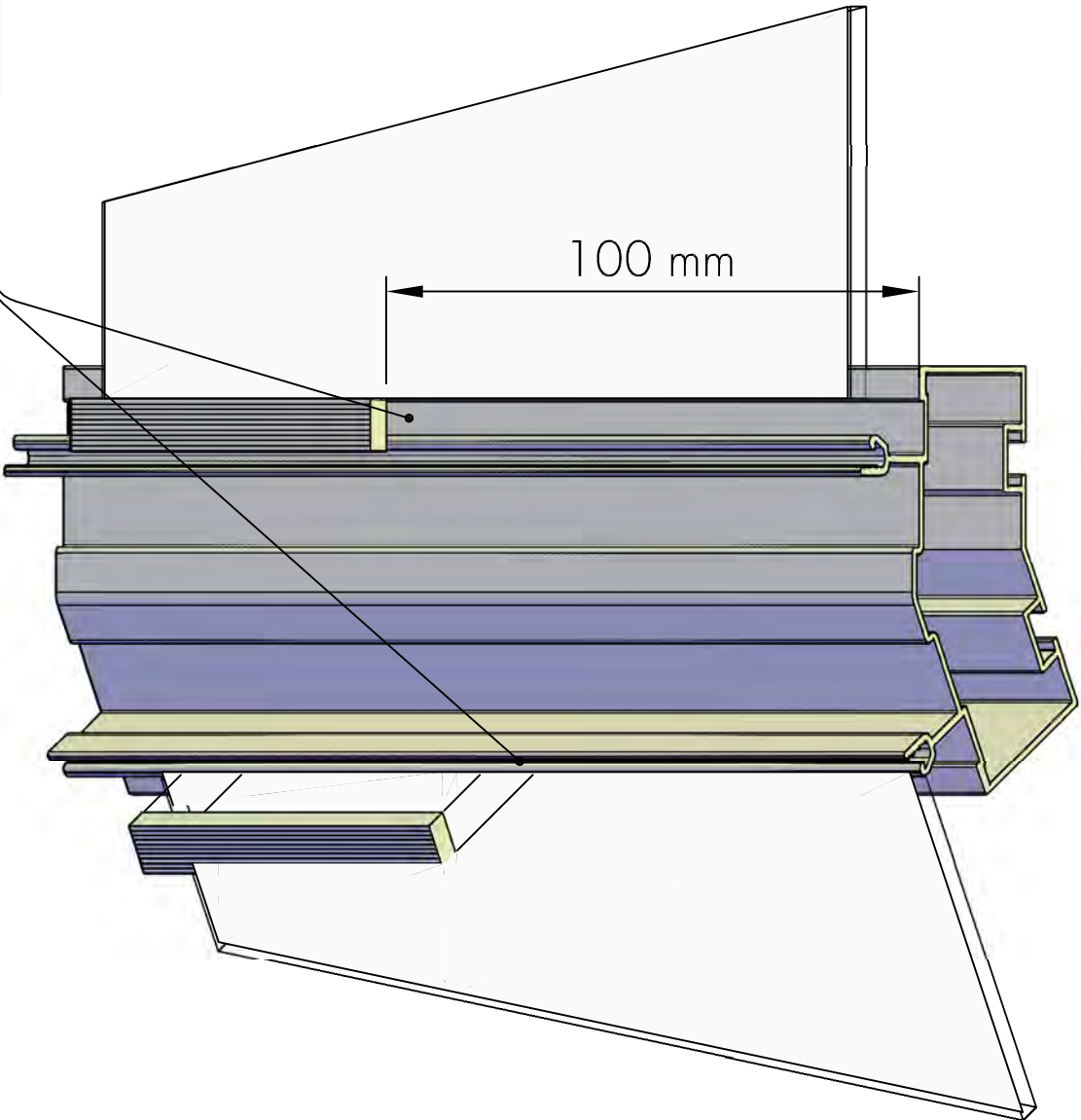

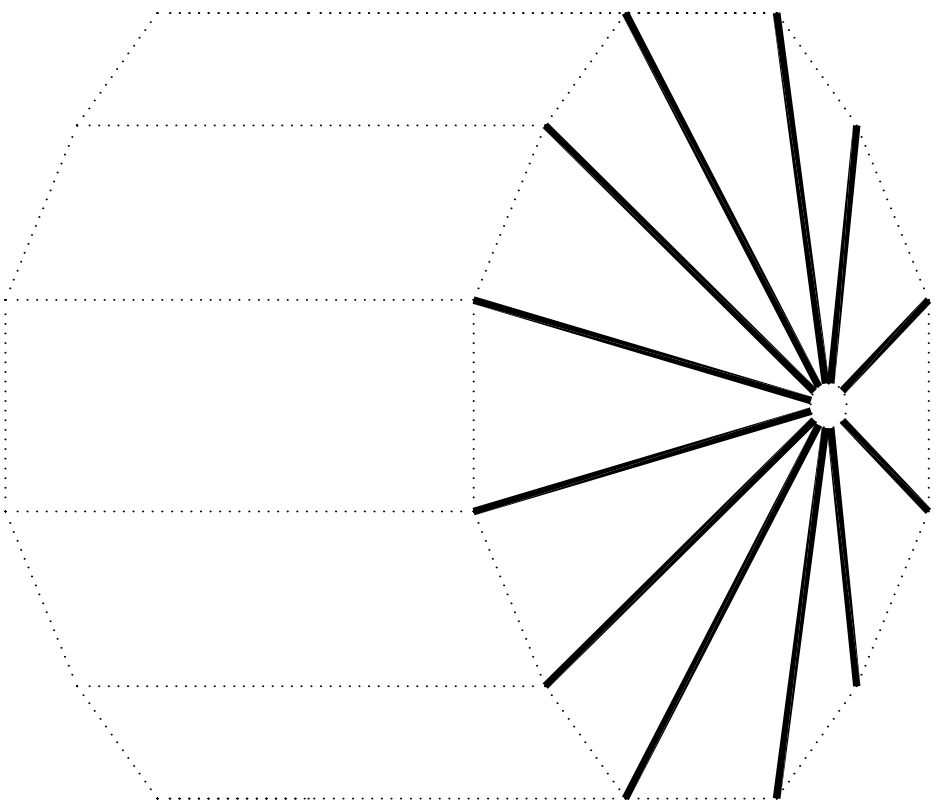
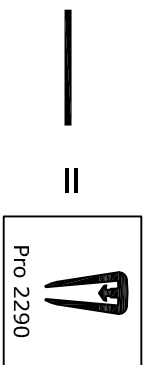
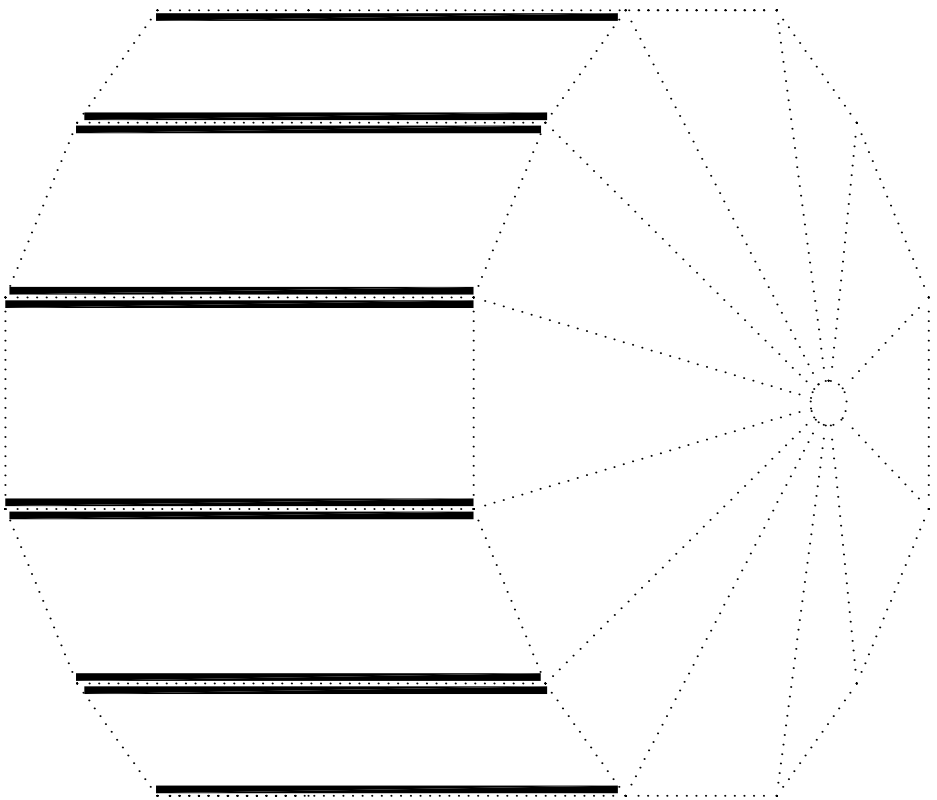
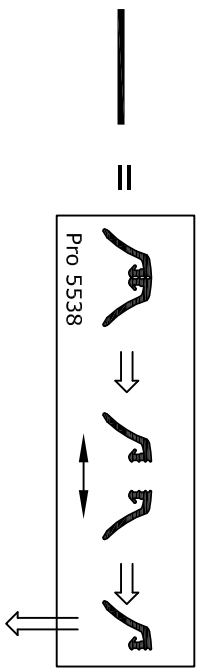

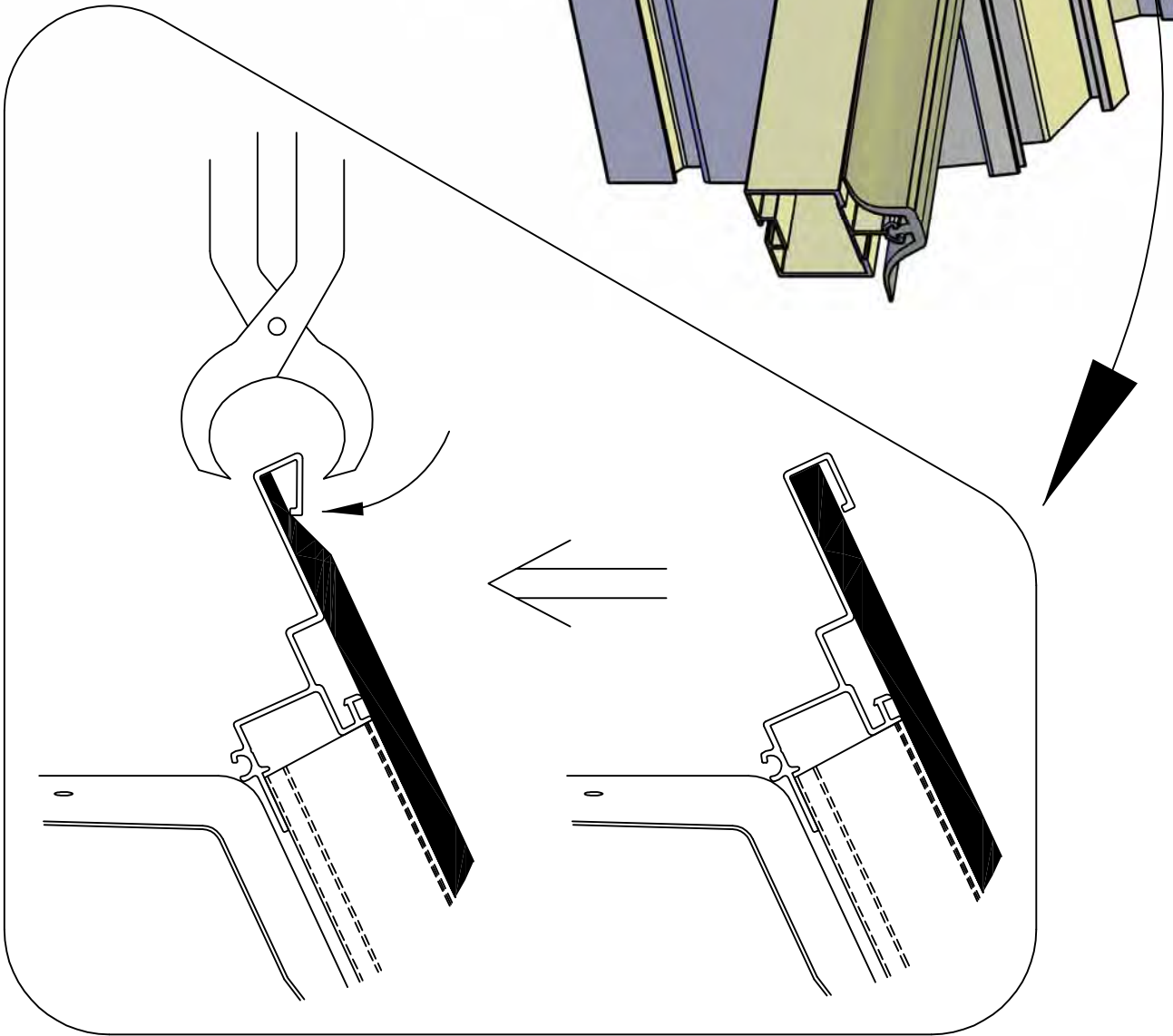
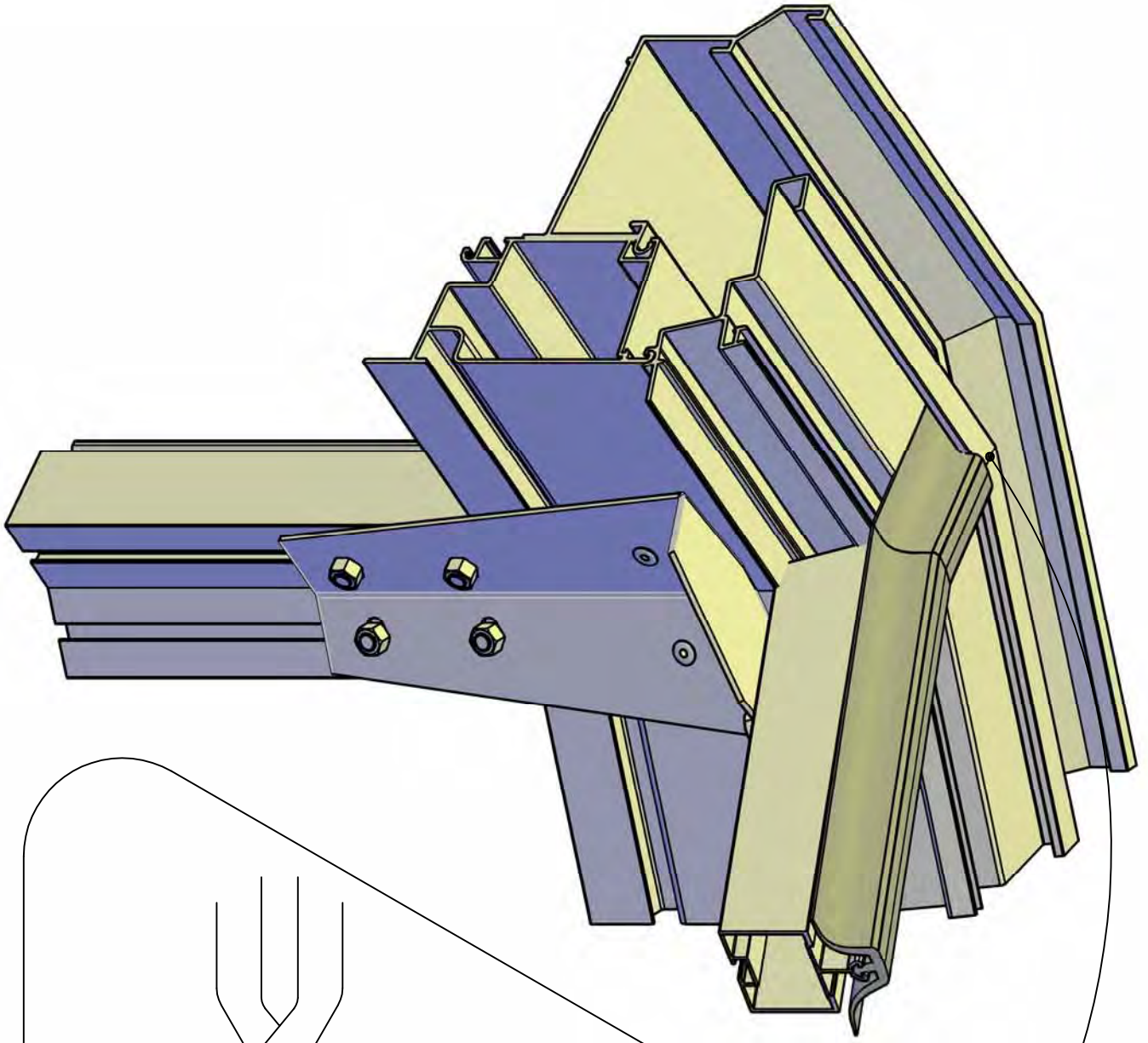

Lammelenraam - Lamellenfenster - Lamellenwindow

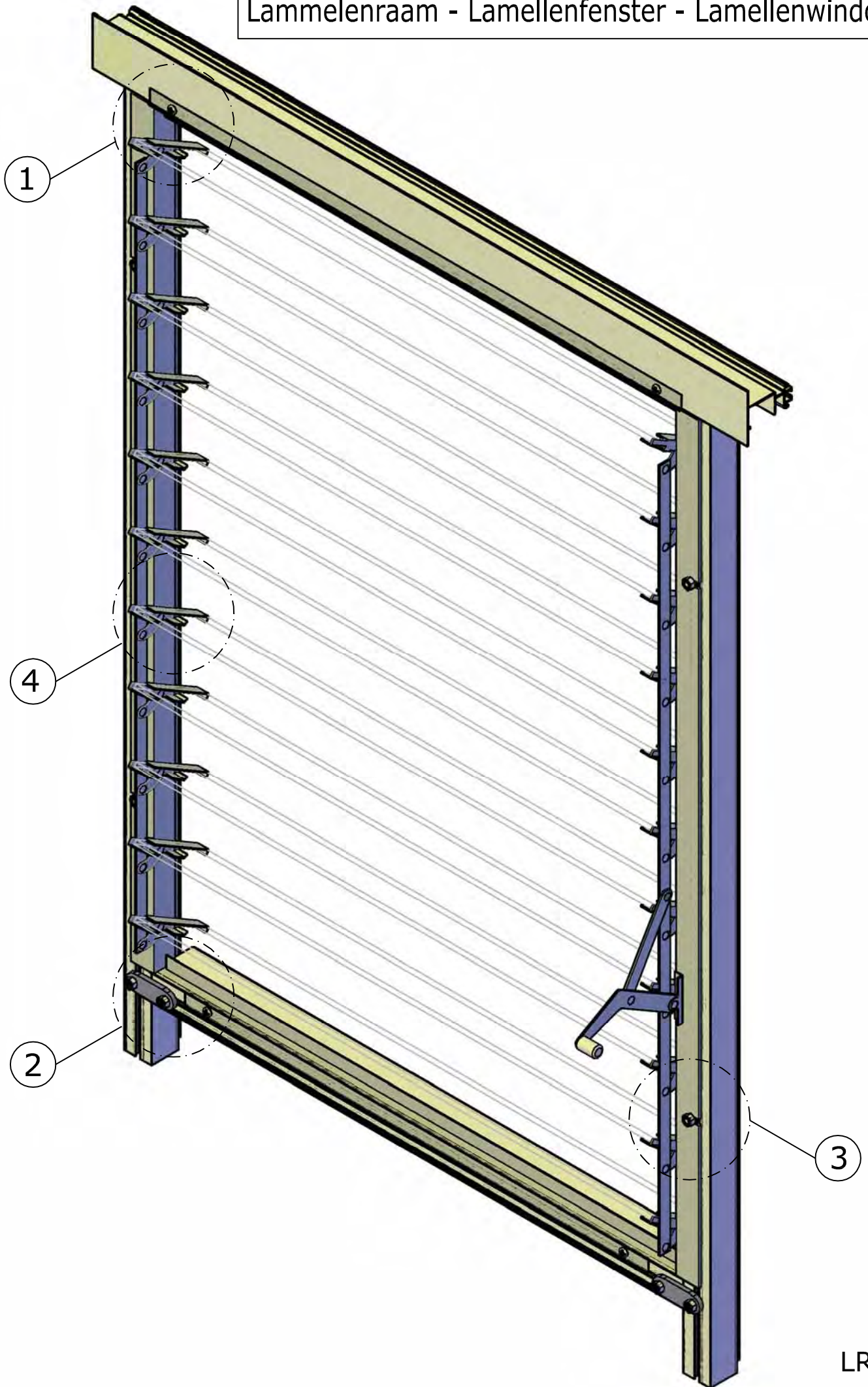

Lammelenraam - Lamellenfenster - Lamellenwindow

1

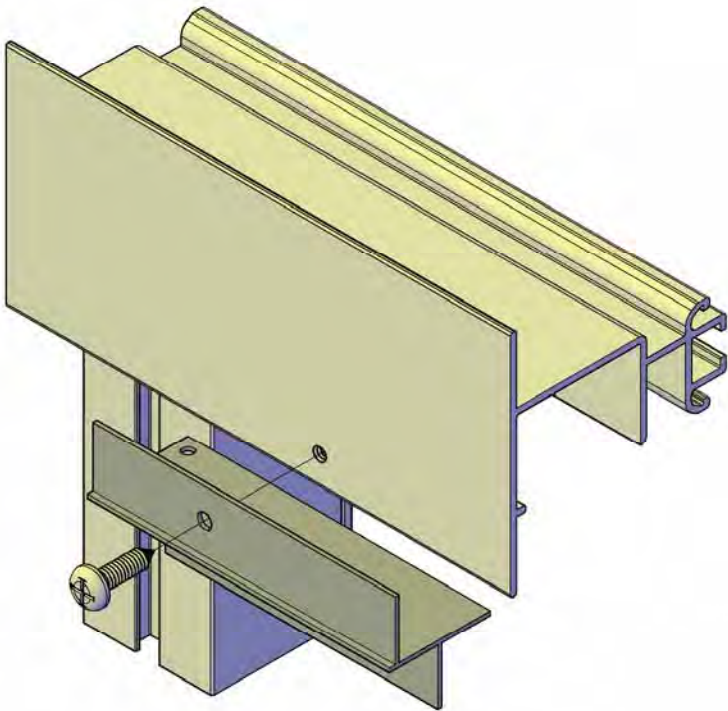

2

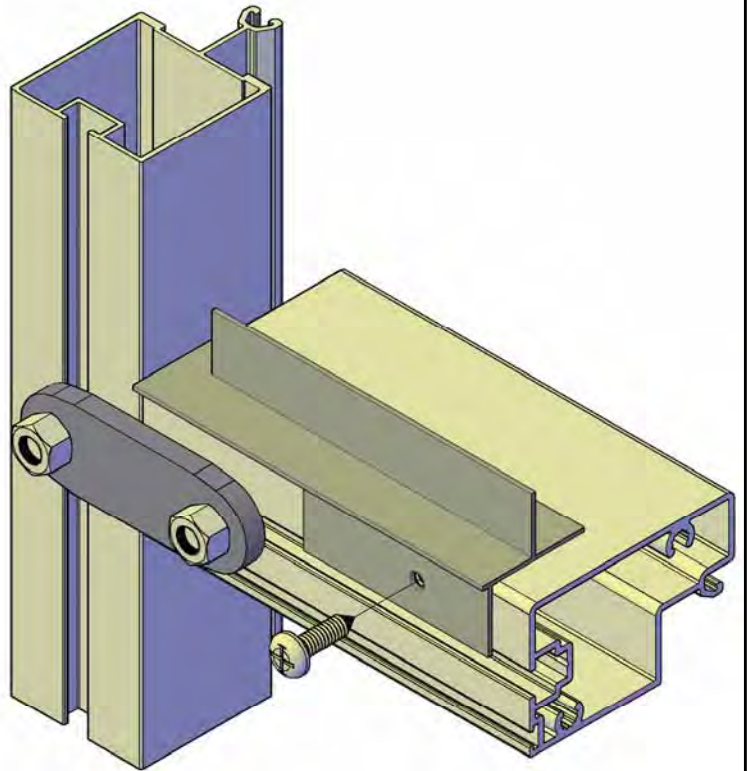

3

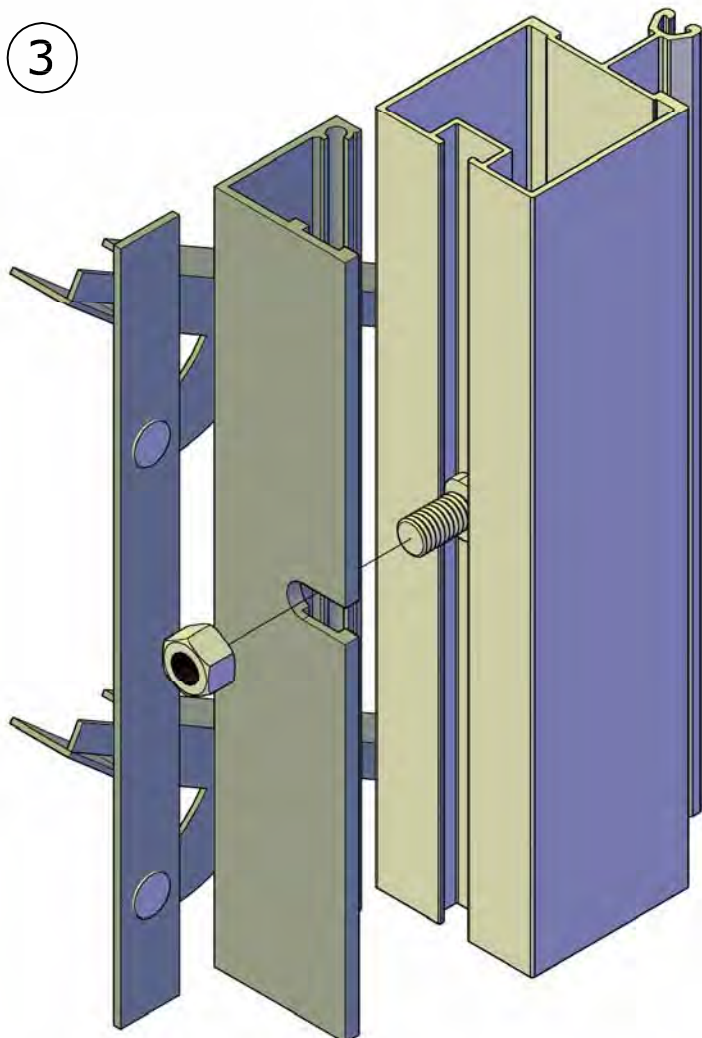

4

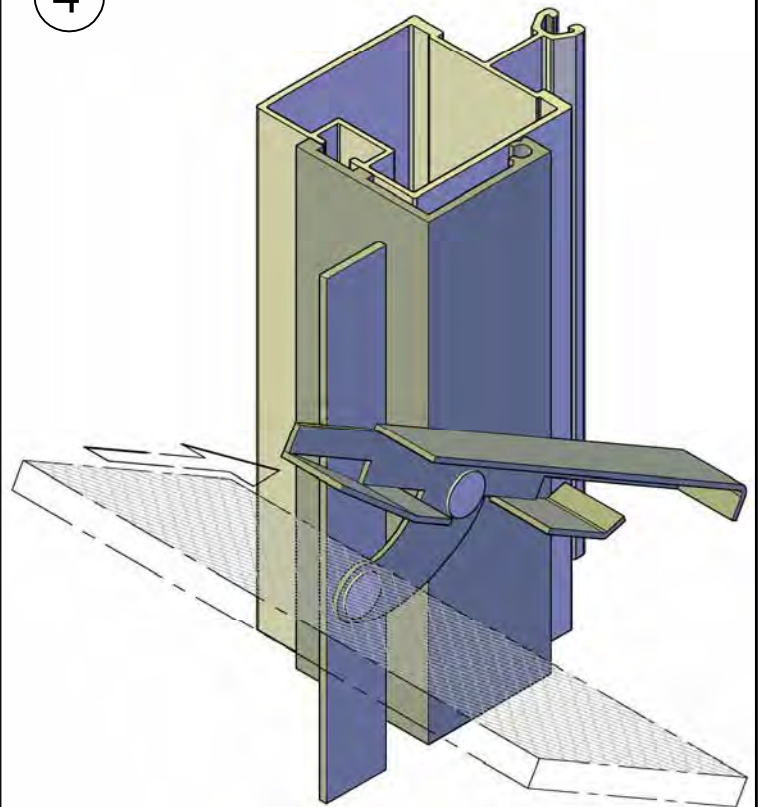

Schuifraam-Fenêtre Coulissante-Schiebefenster-Sliding window
Skydevindue-Skyvefönster-Skuggvindue-Finestra scorrevole

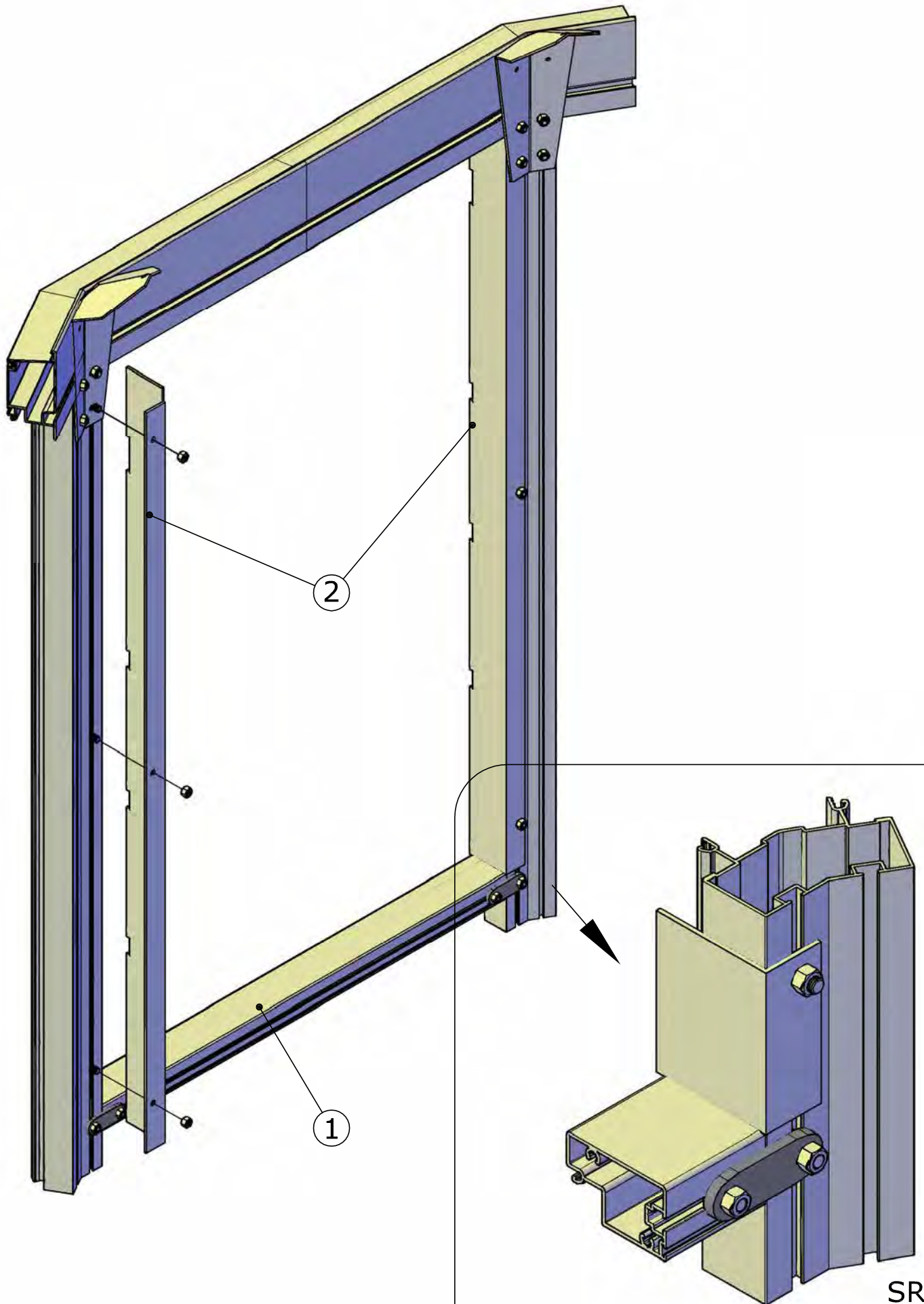

SR1

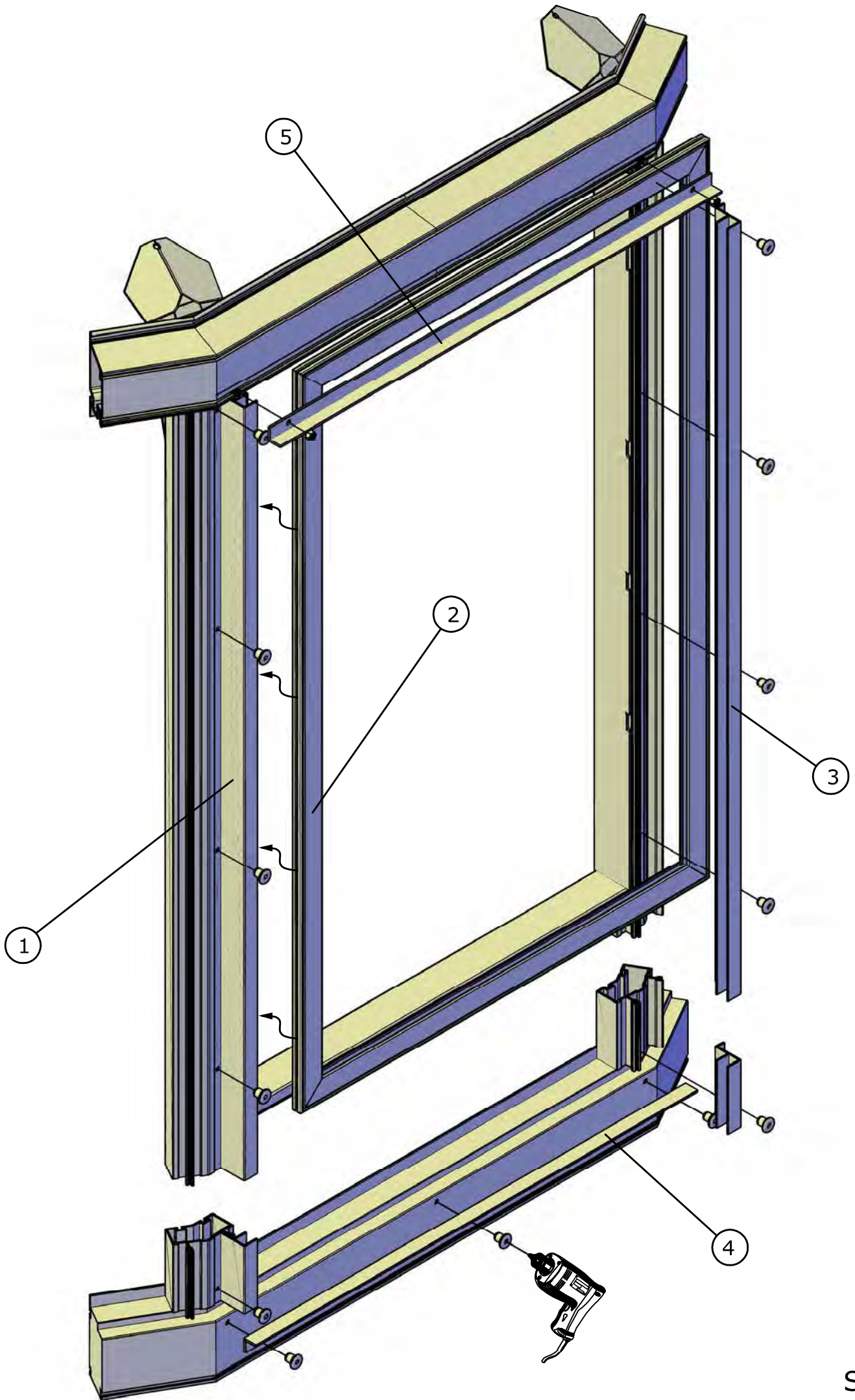

PYRAMIDE

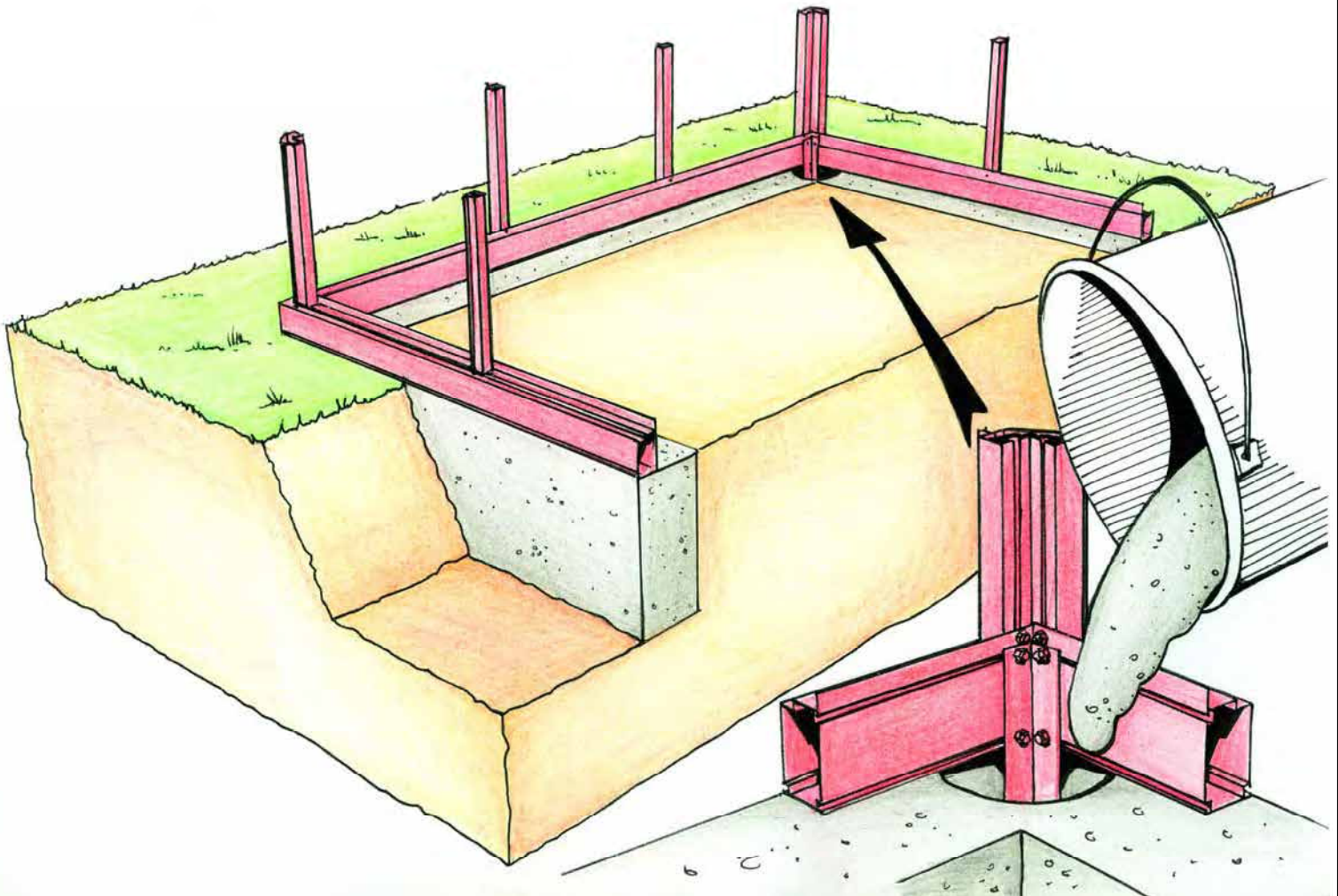
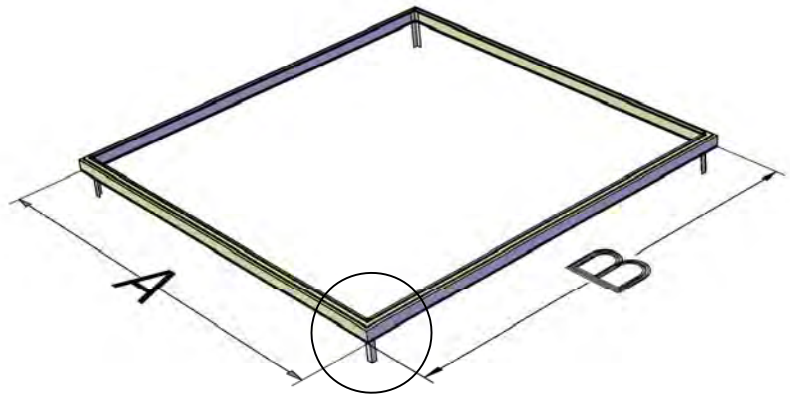

" PYRAMIDE "

A	X	B
3.100mm		3.100mm
3.800mm		3.800mm

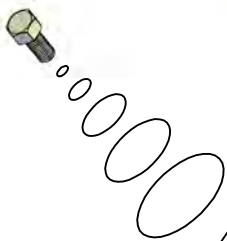
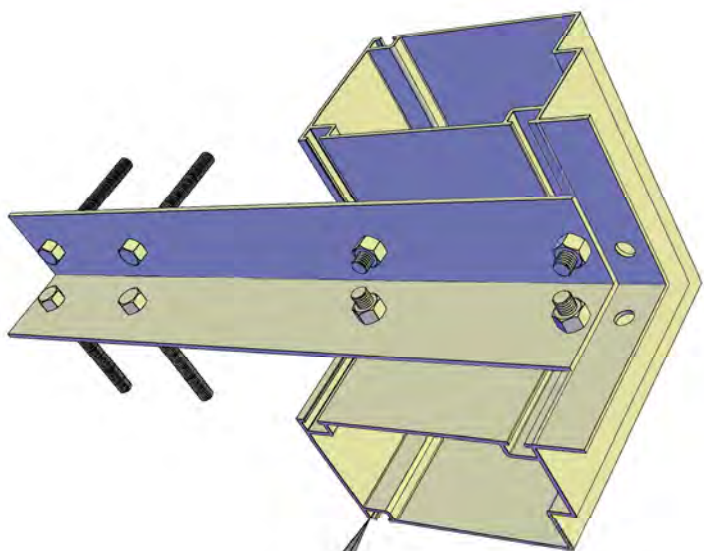
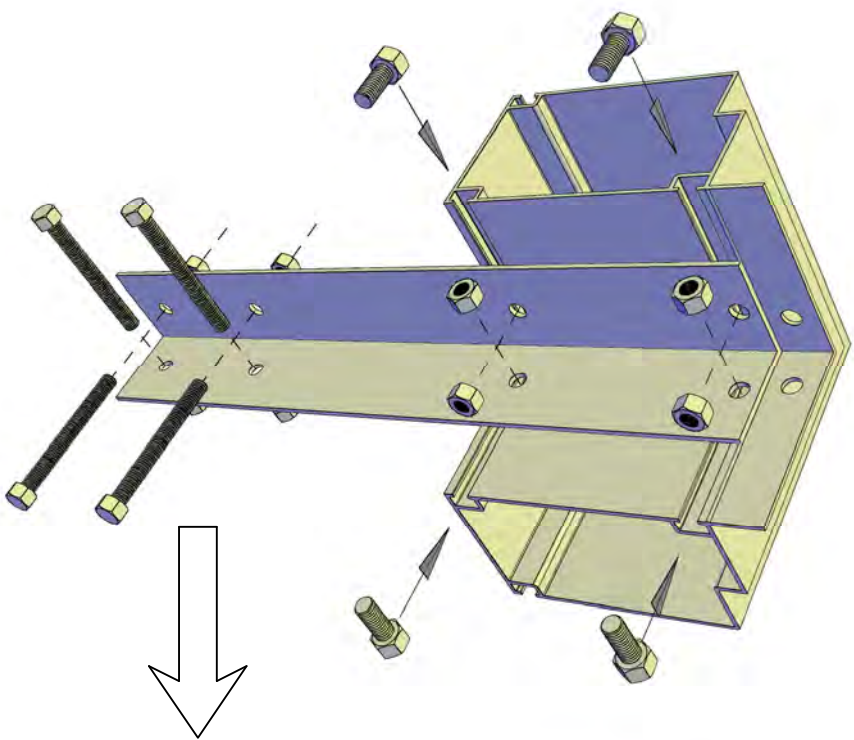

A



 = S1 -->  3x

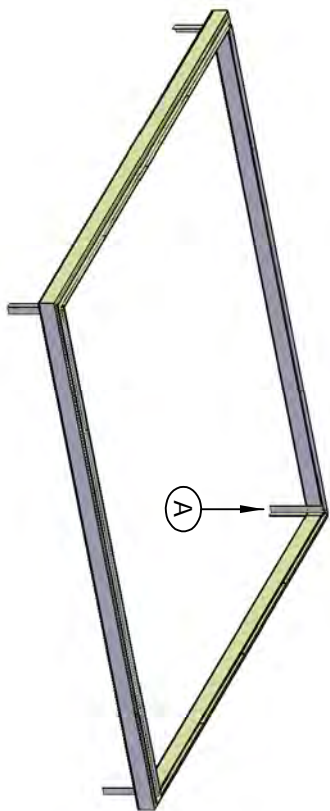

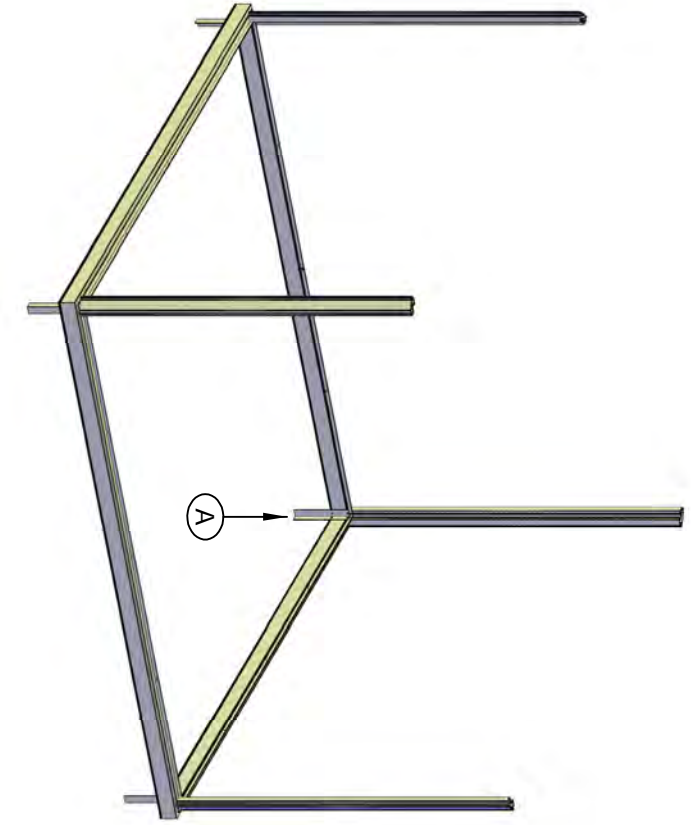

A

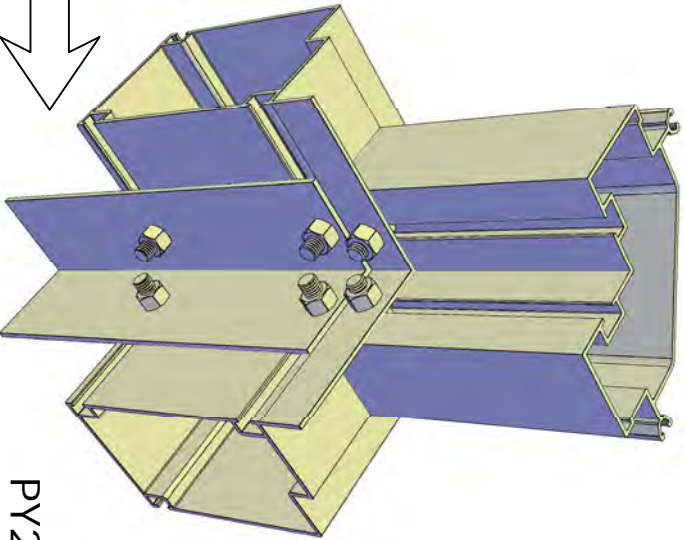
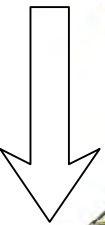
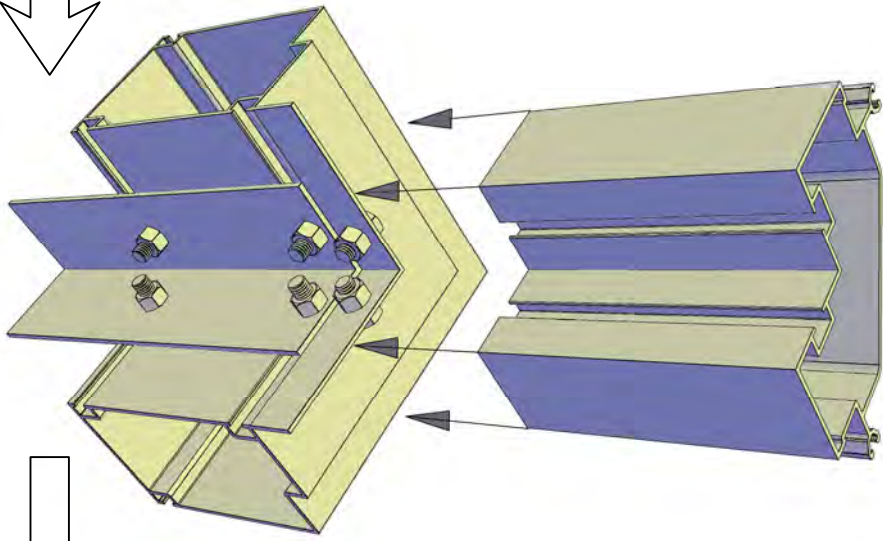
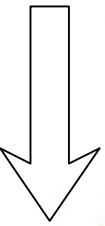
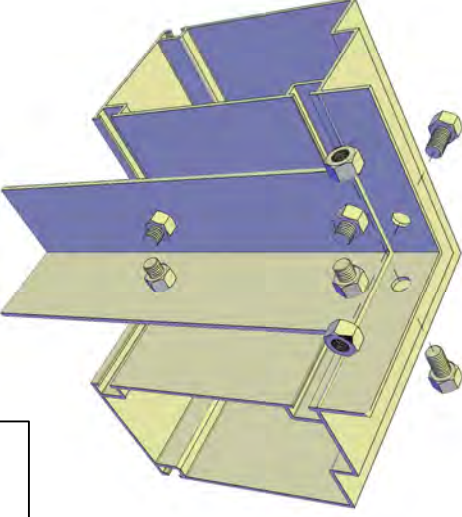

PY2

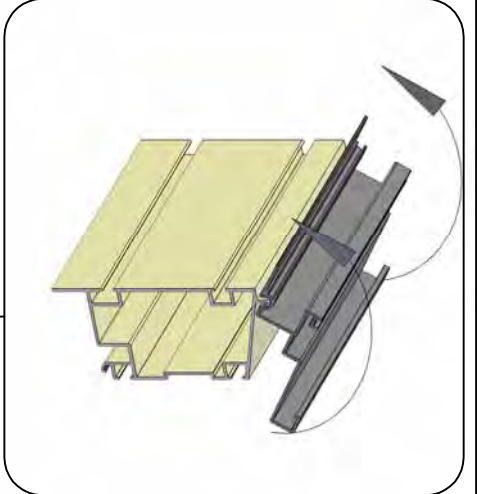
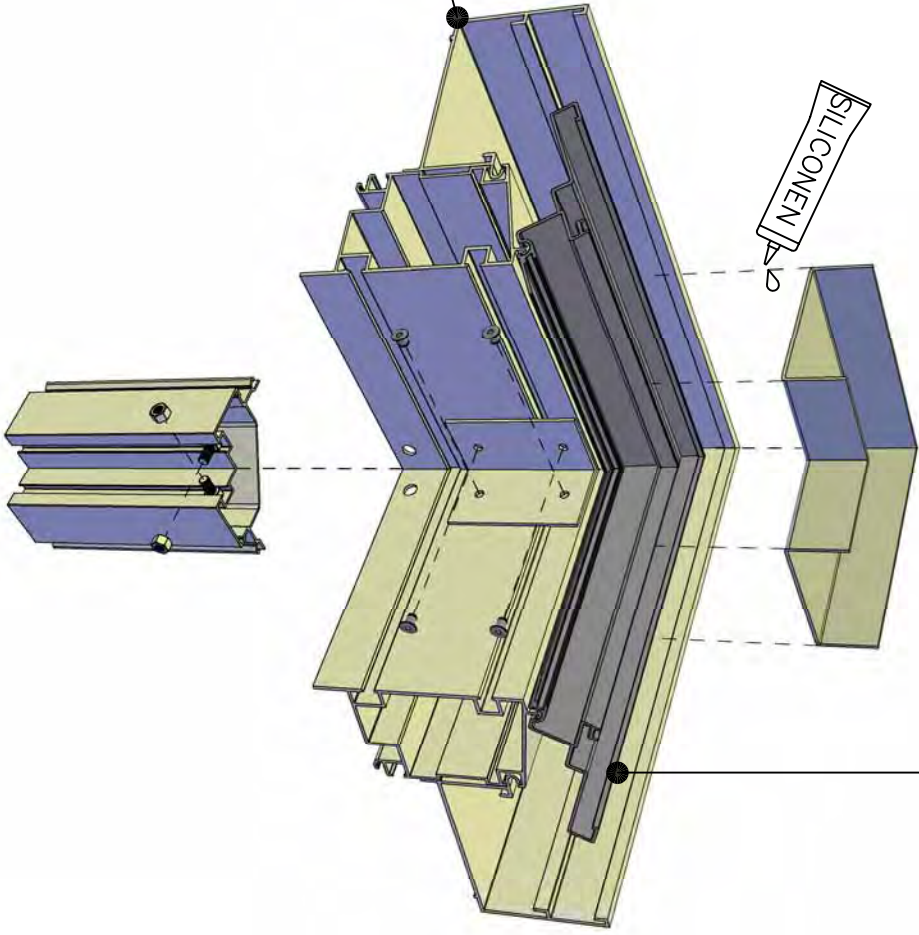
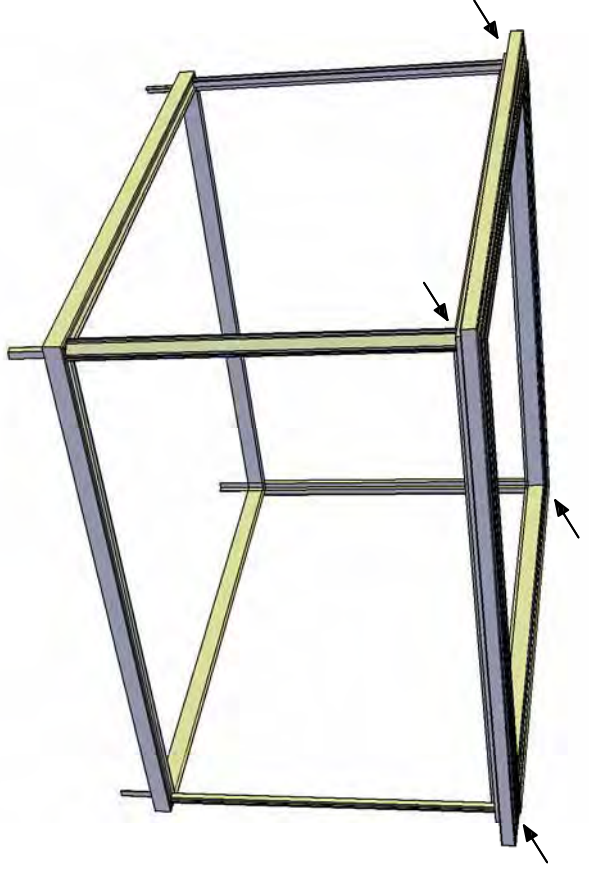
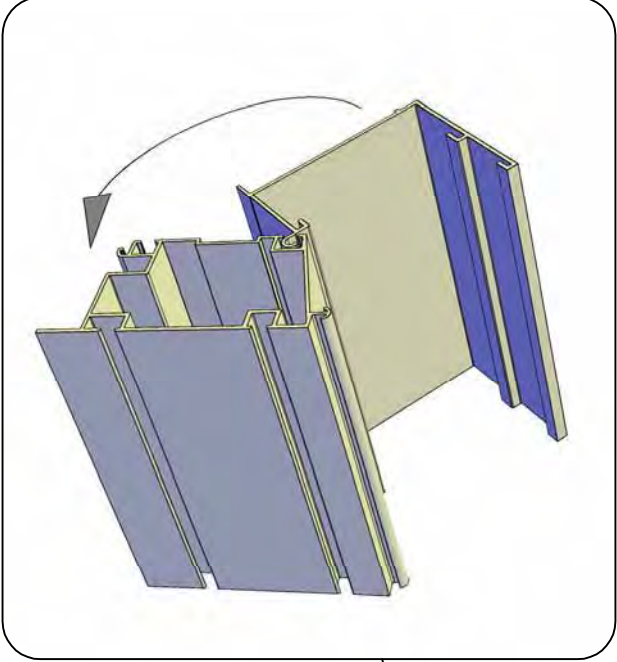

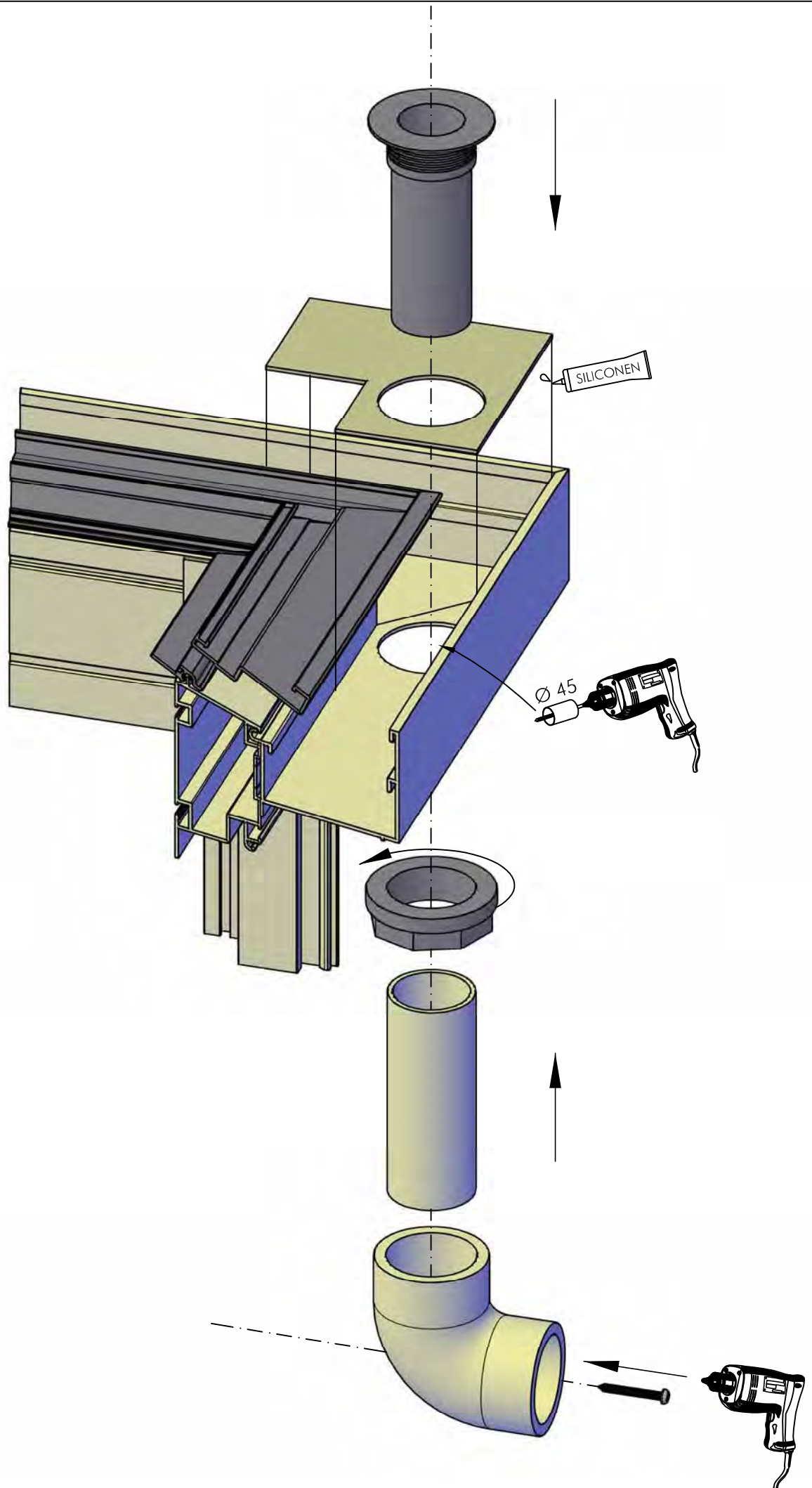

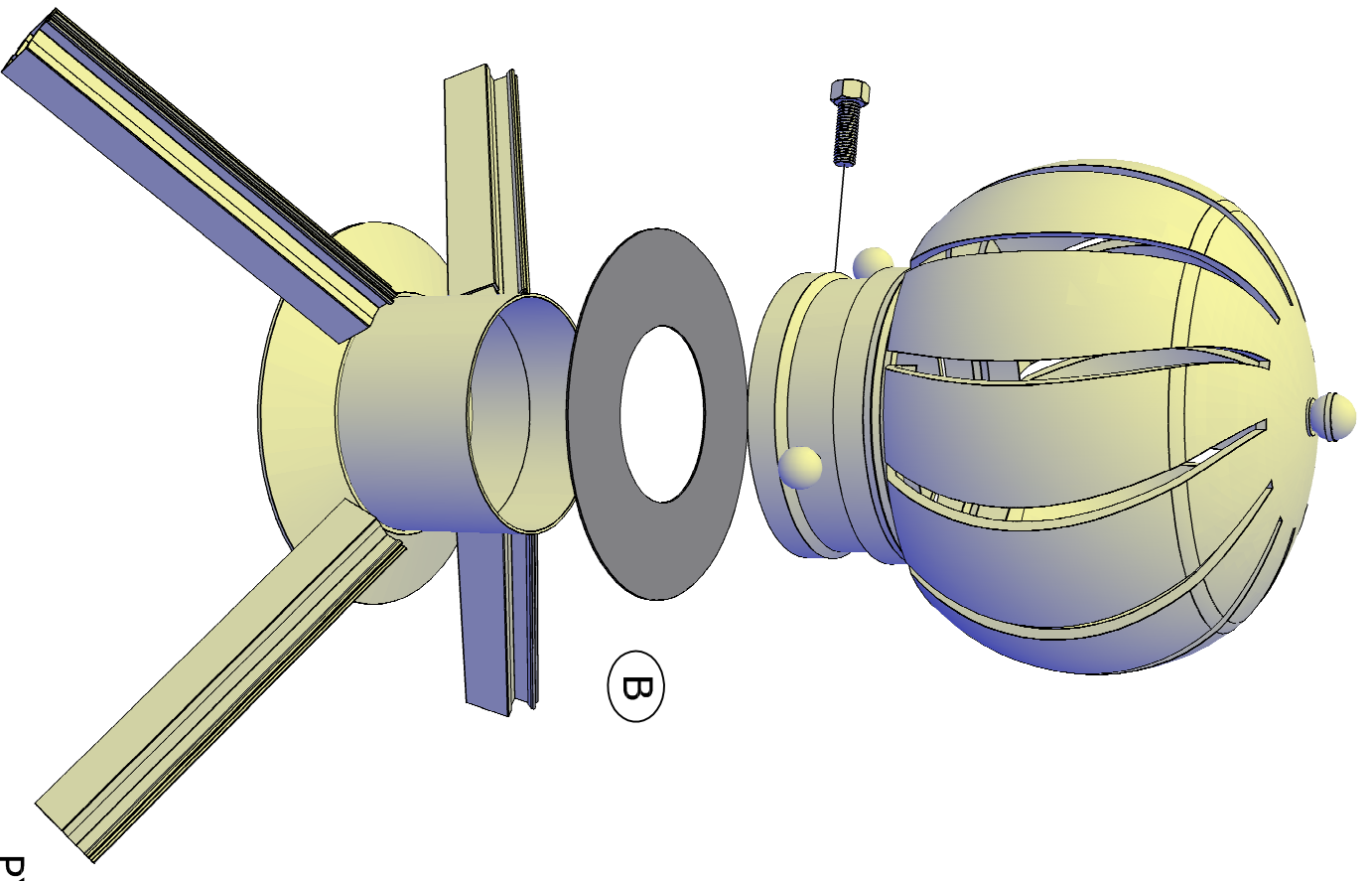
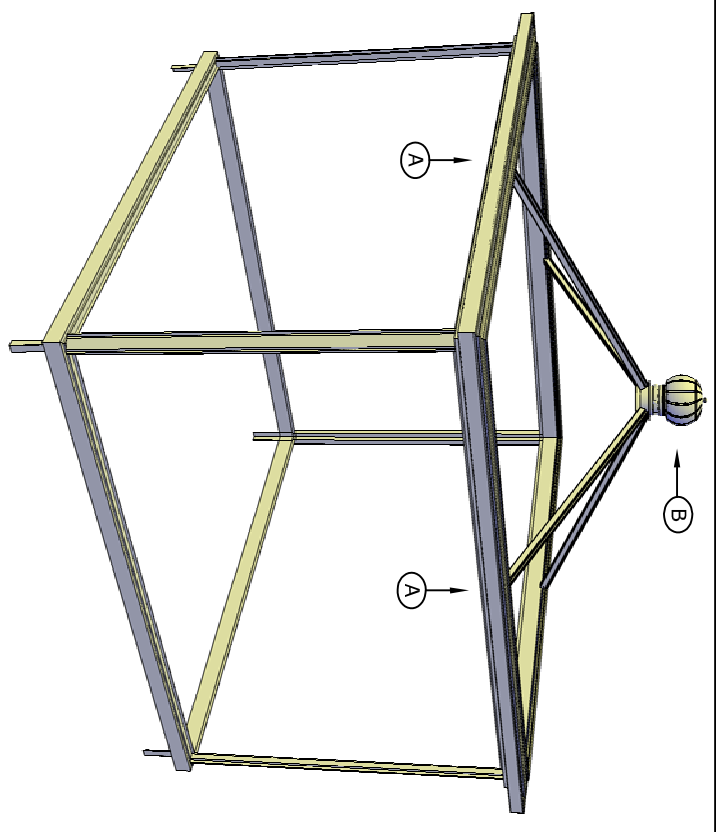
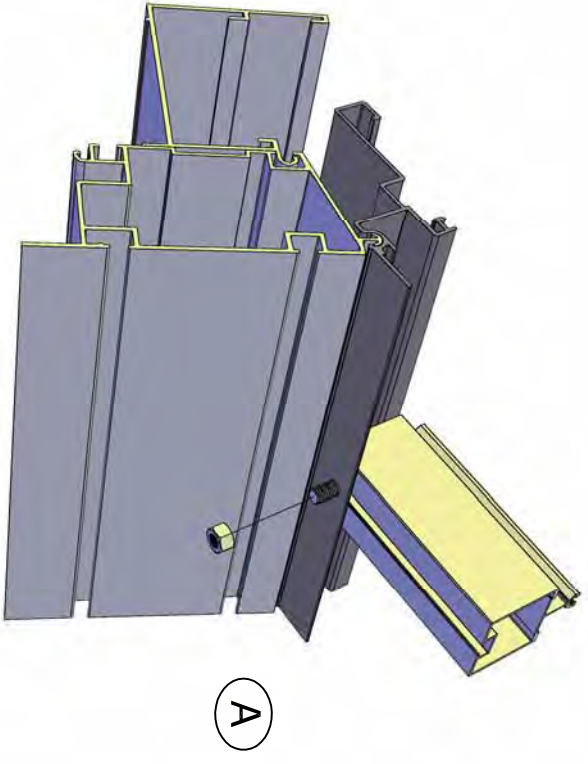

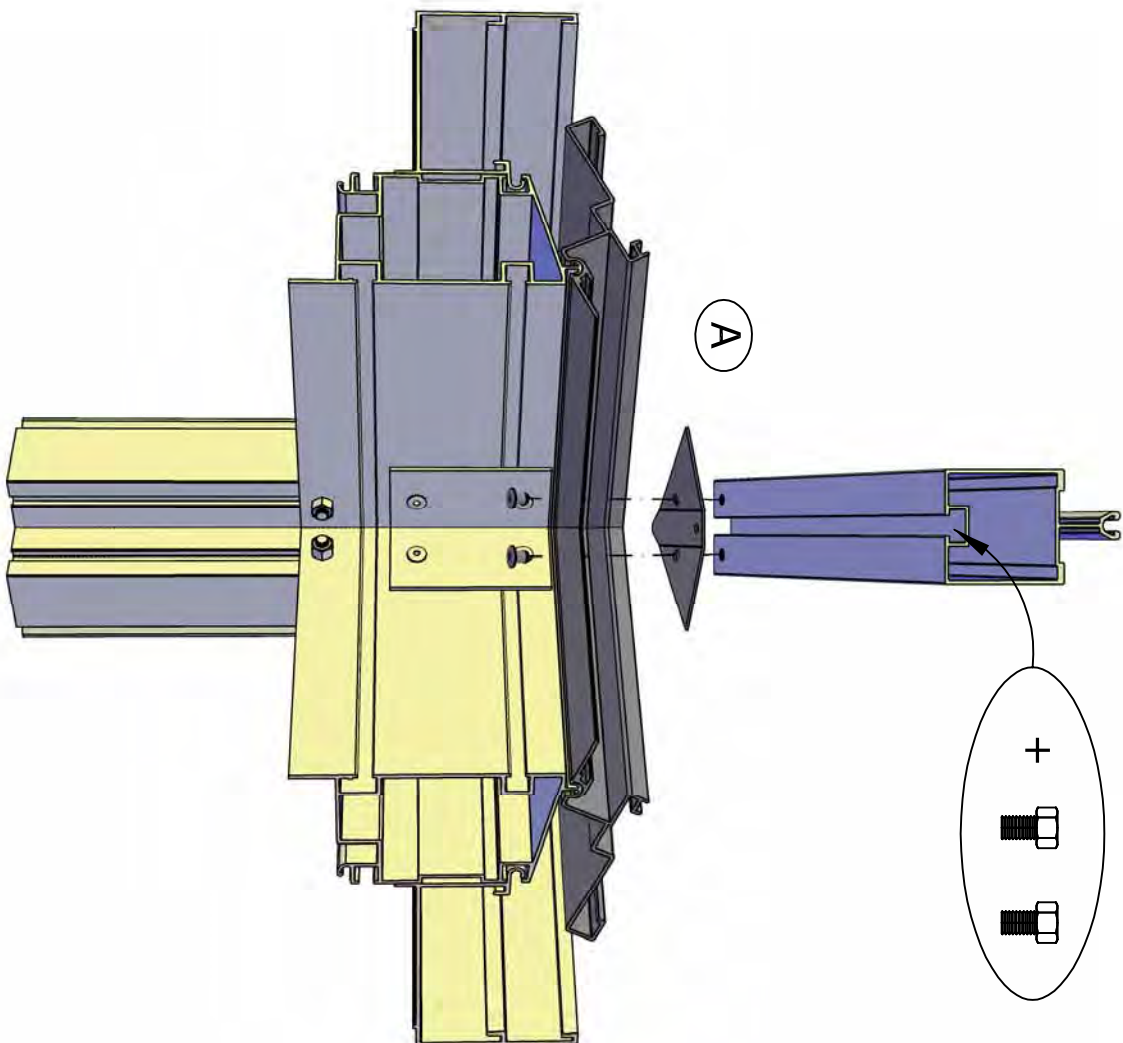
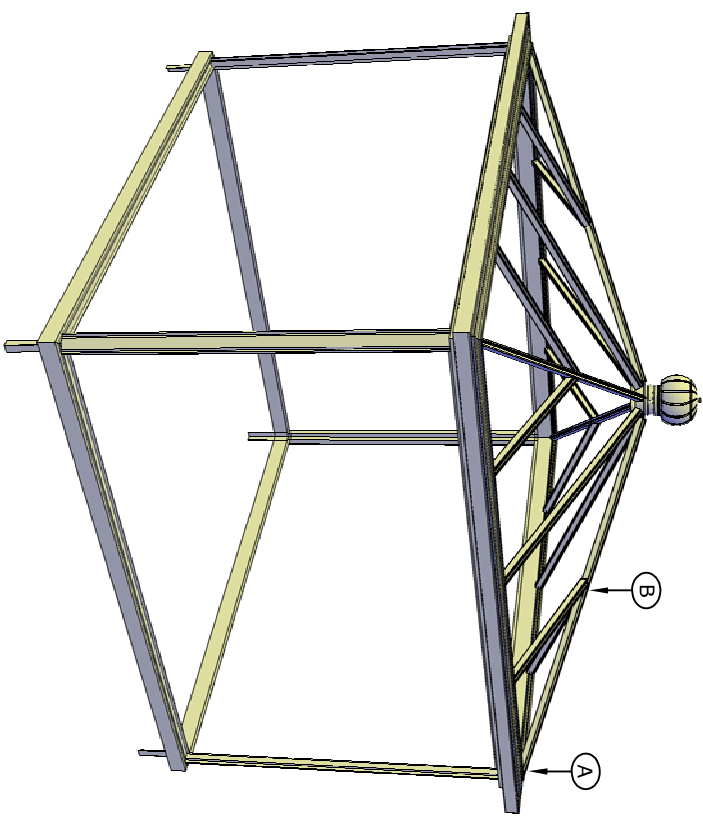
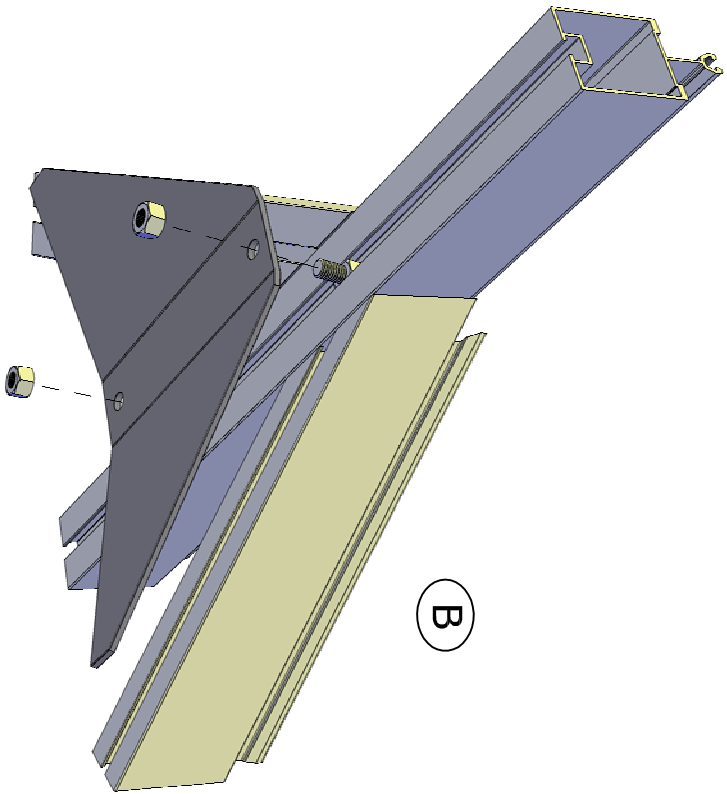

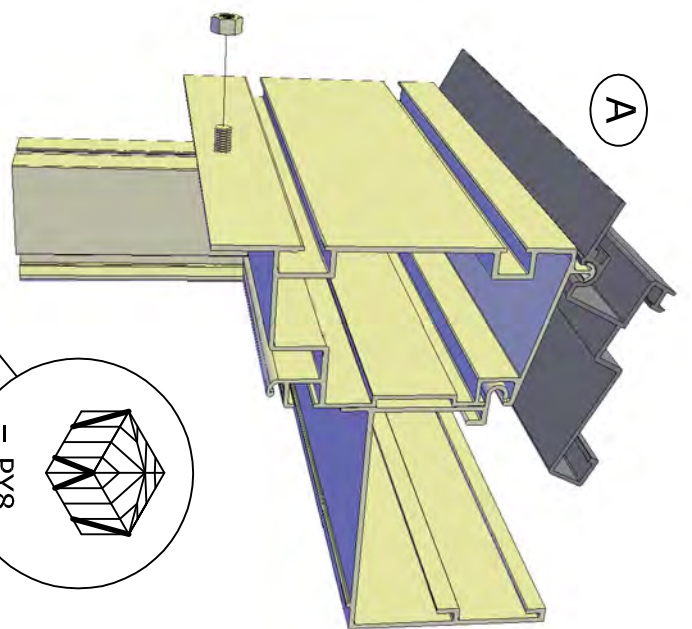
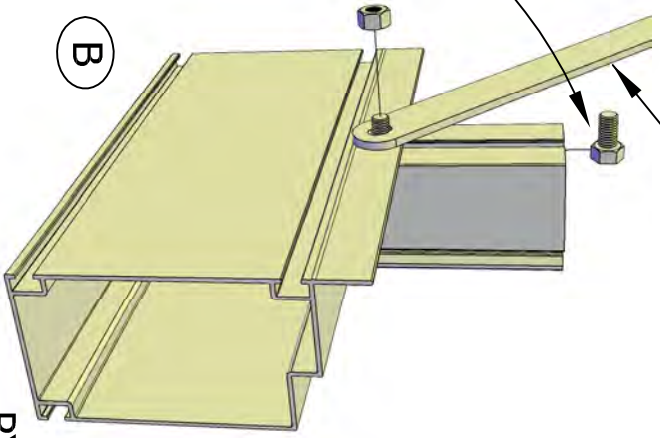
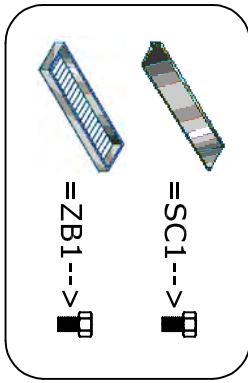
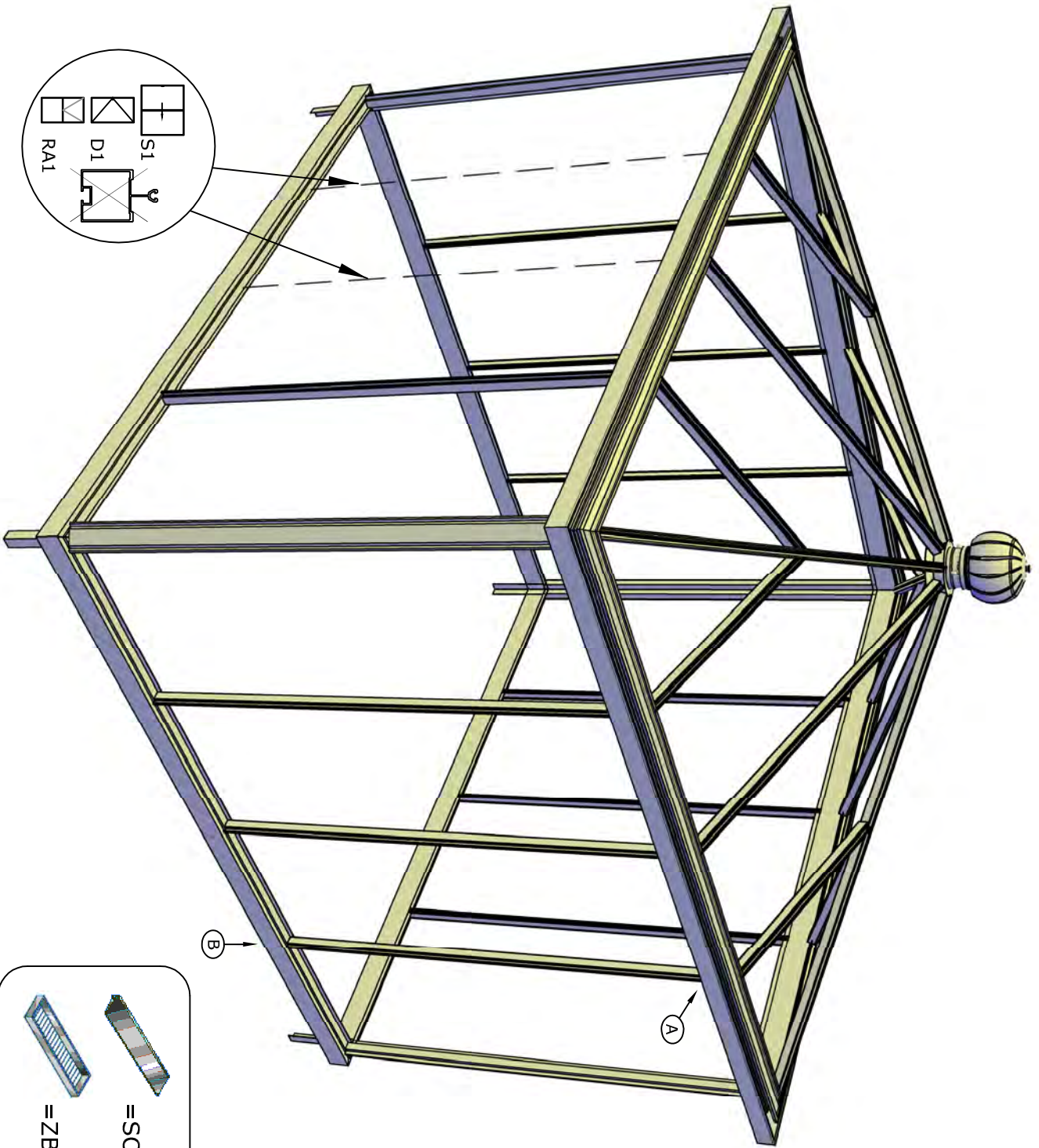

PY7

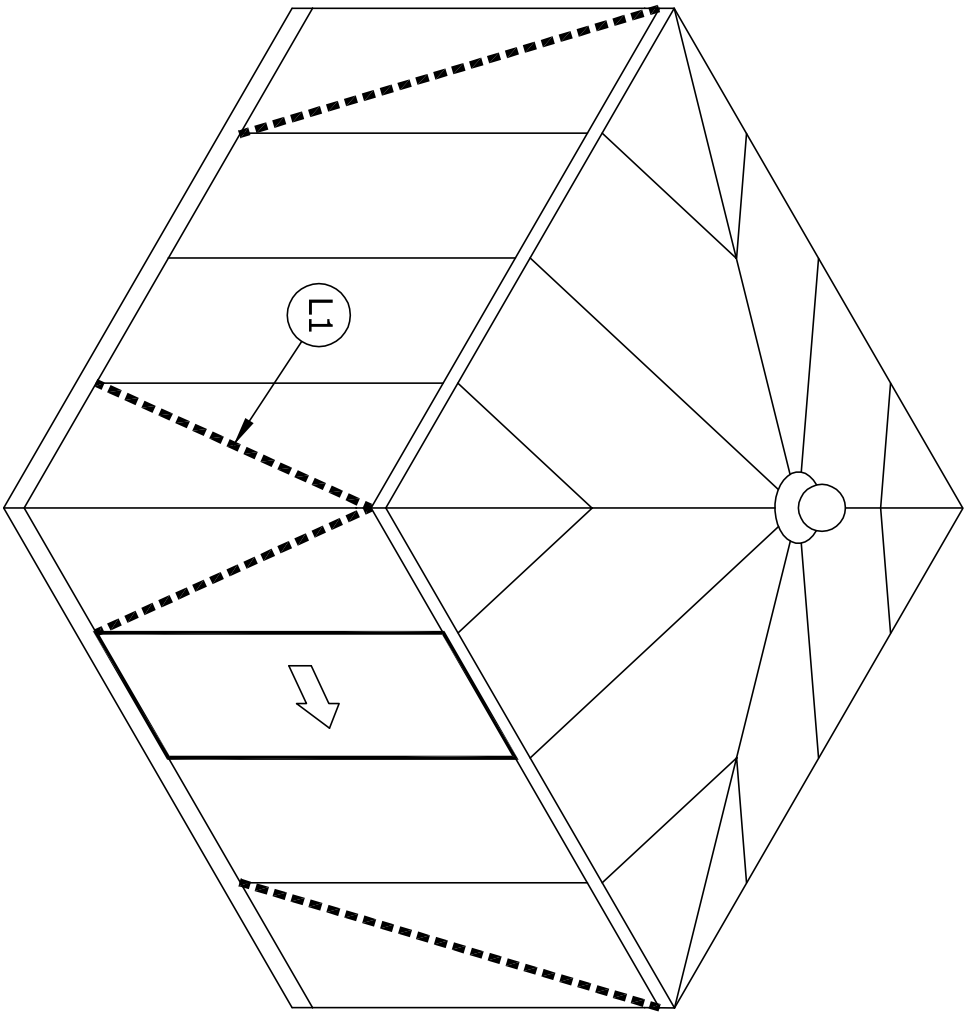

L1 = 1975 mm (MODEL 310)
2048 mm (MODEL 384)

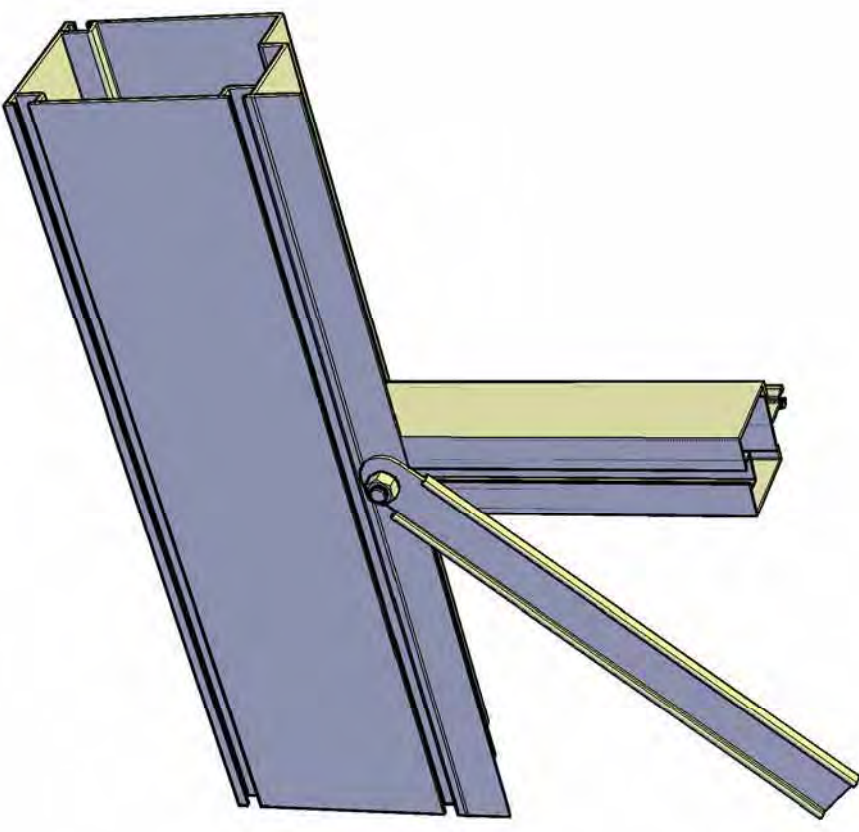

!!! K-glas: ● = OUTSIDE / Innerseite / Intérieur

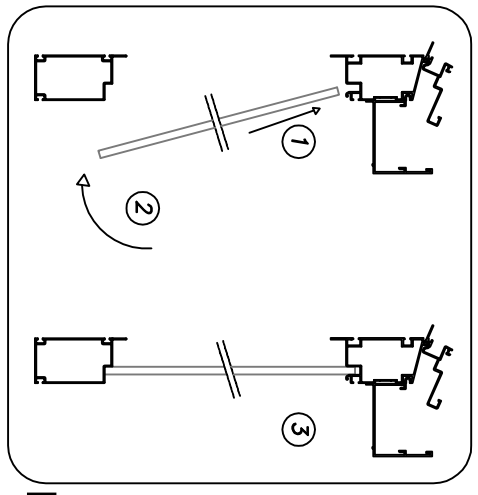
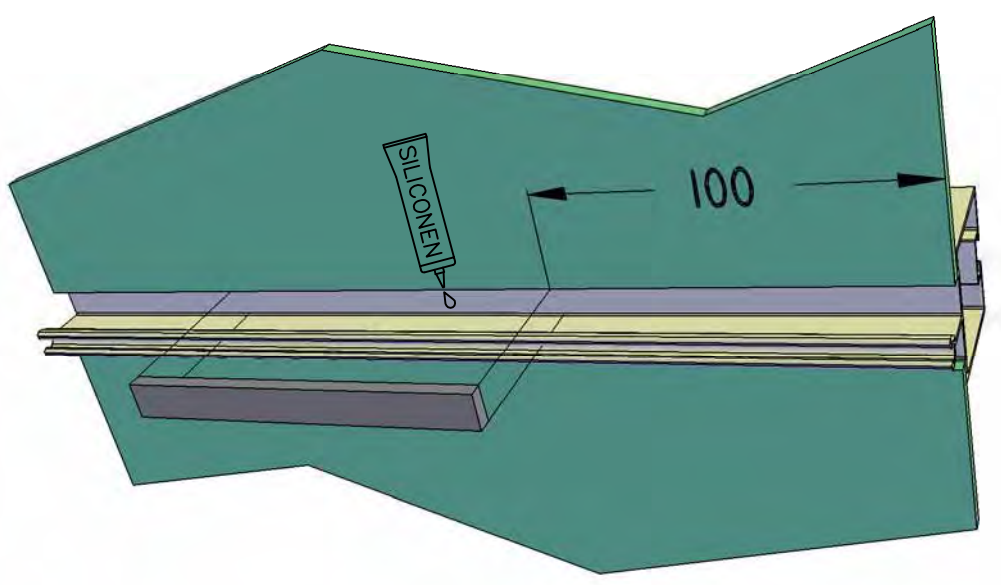
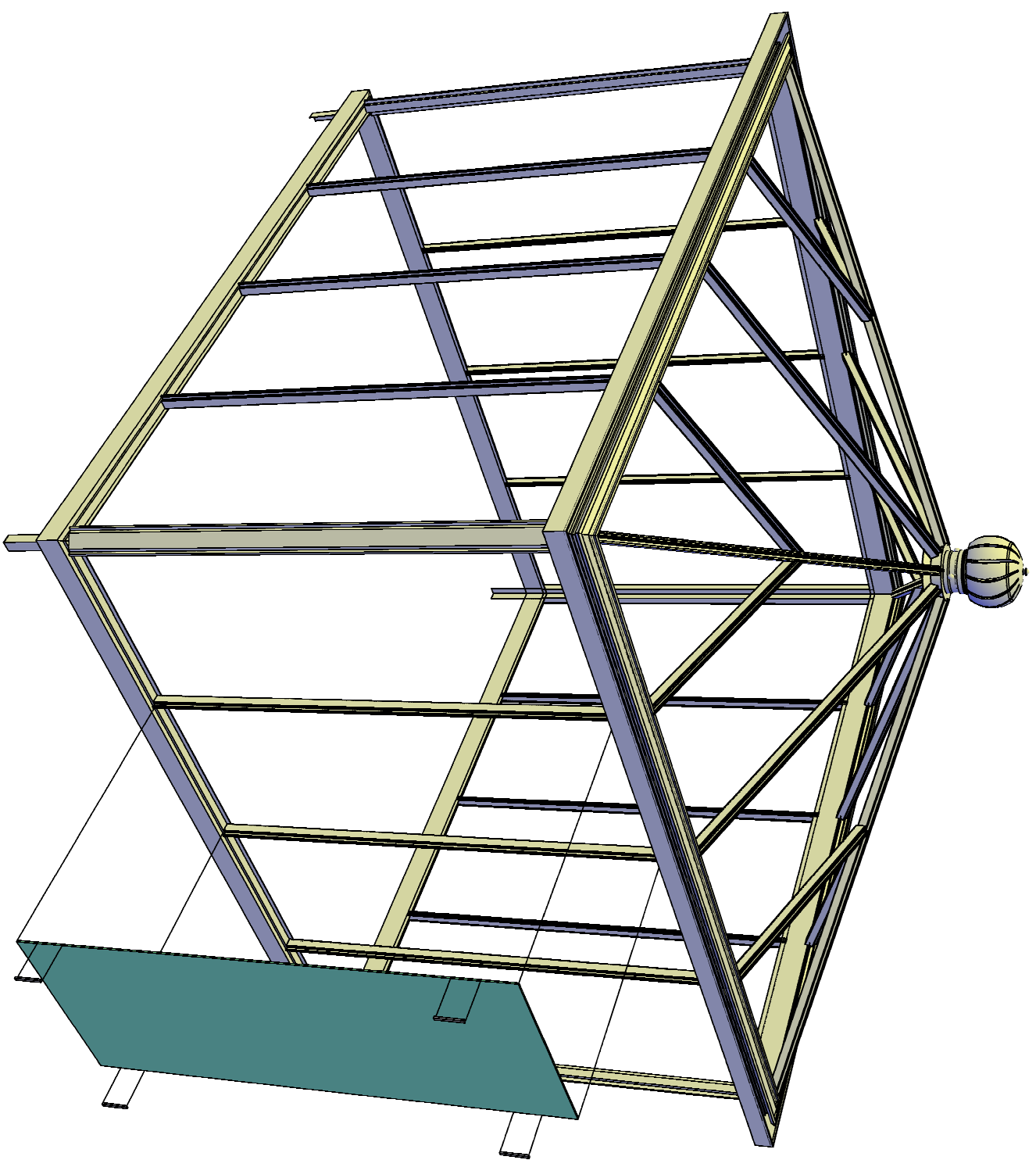

PY9

Pro 2290

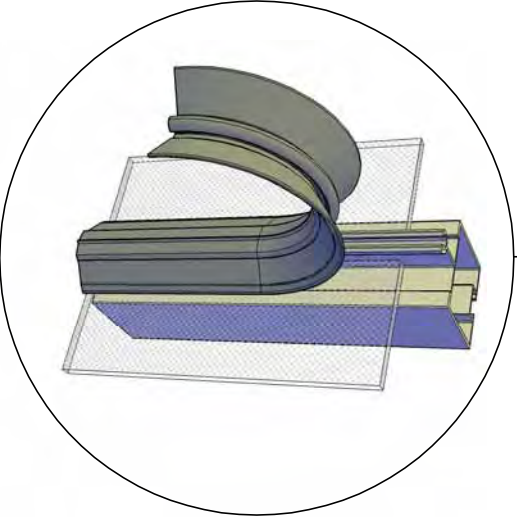
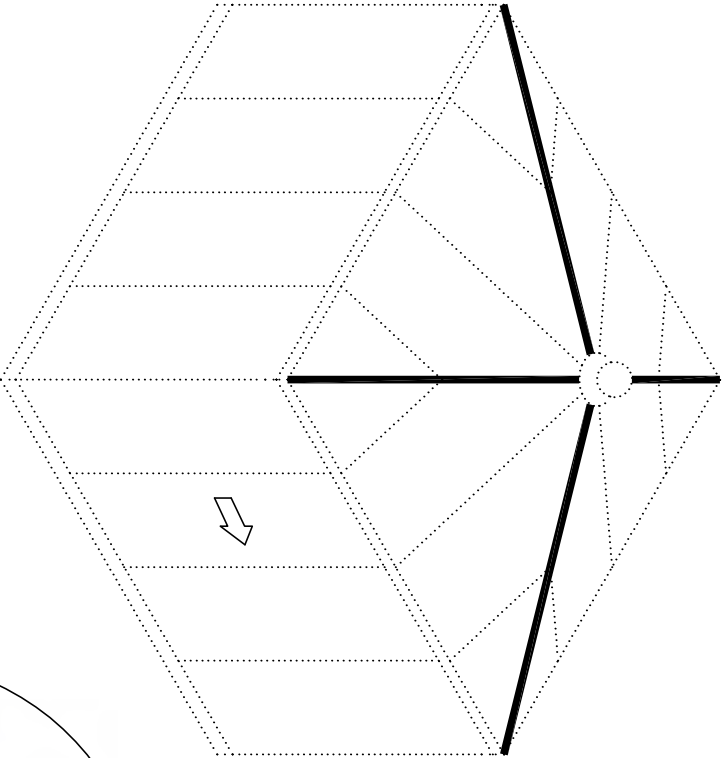
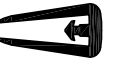

Pro 1748

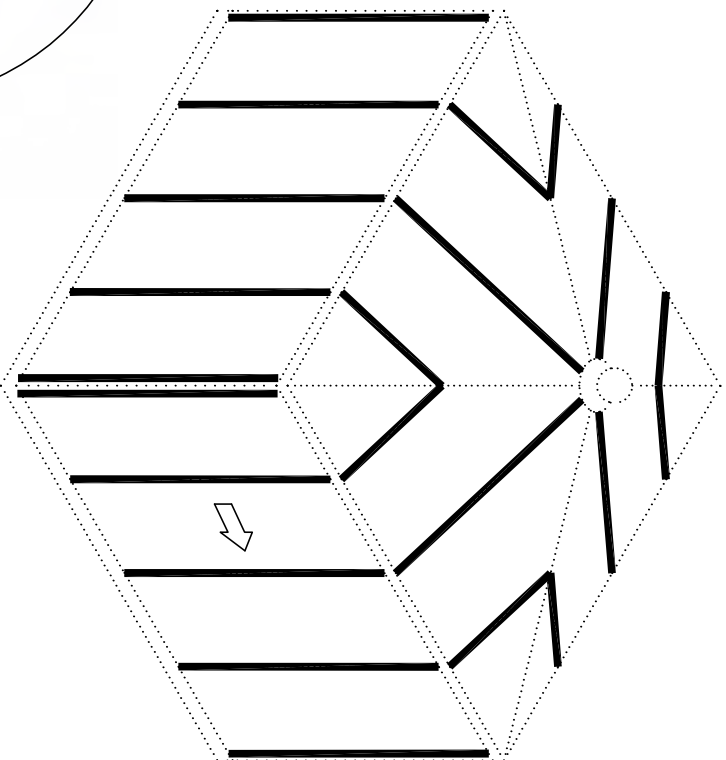

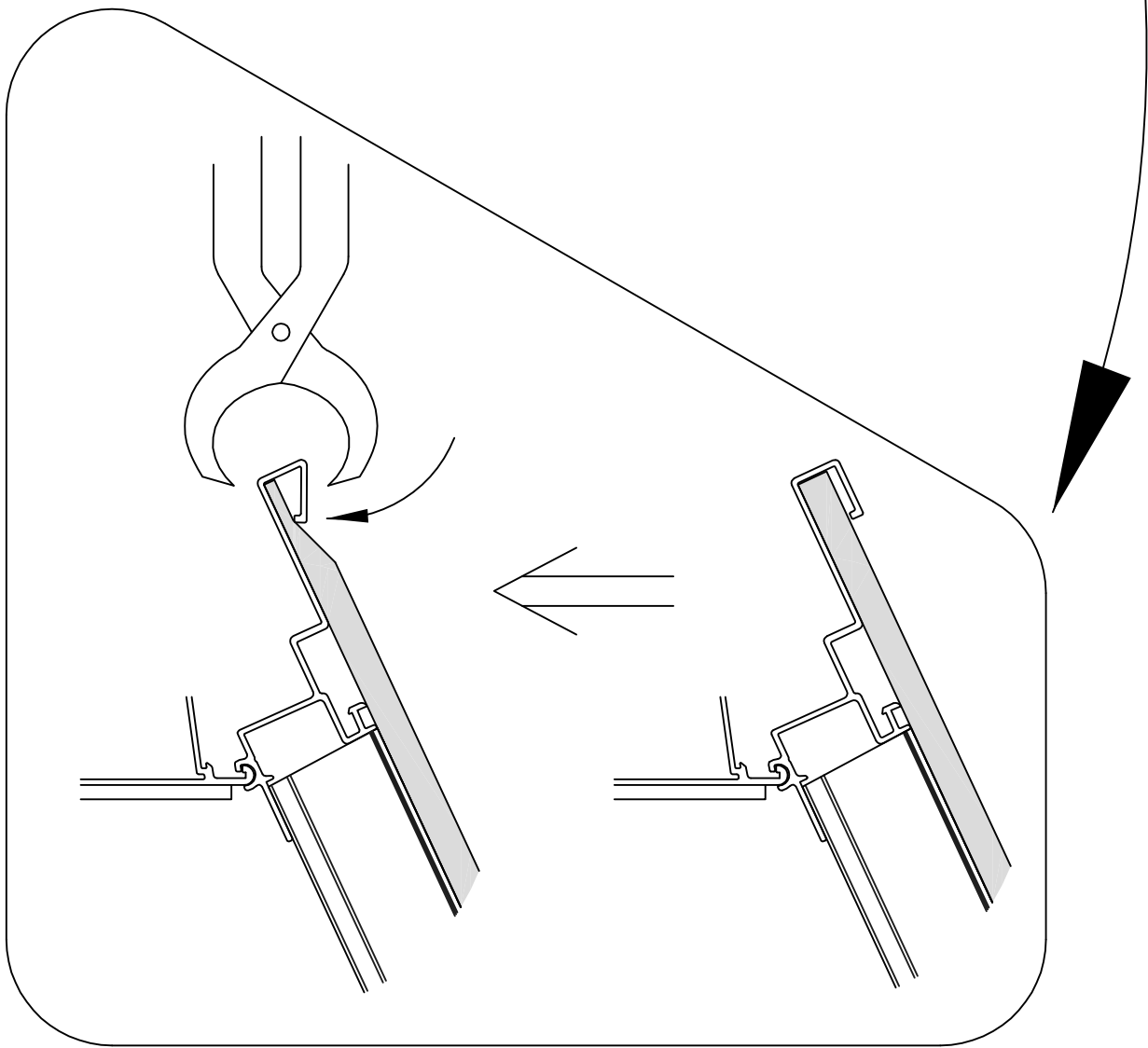
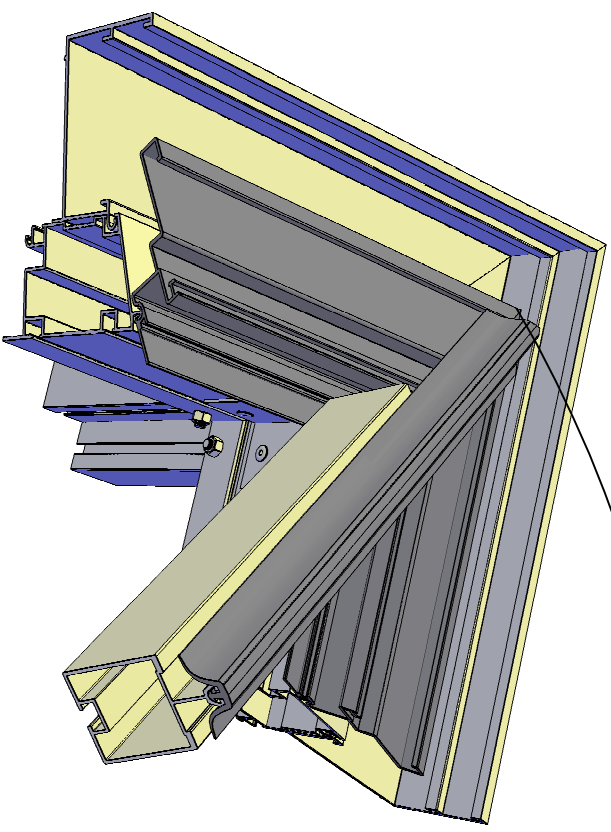

PY11

GIGANT

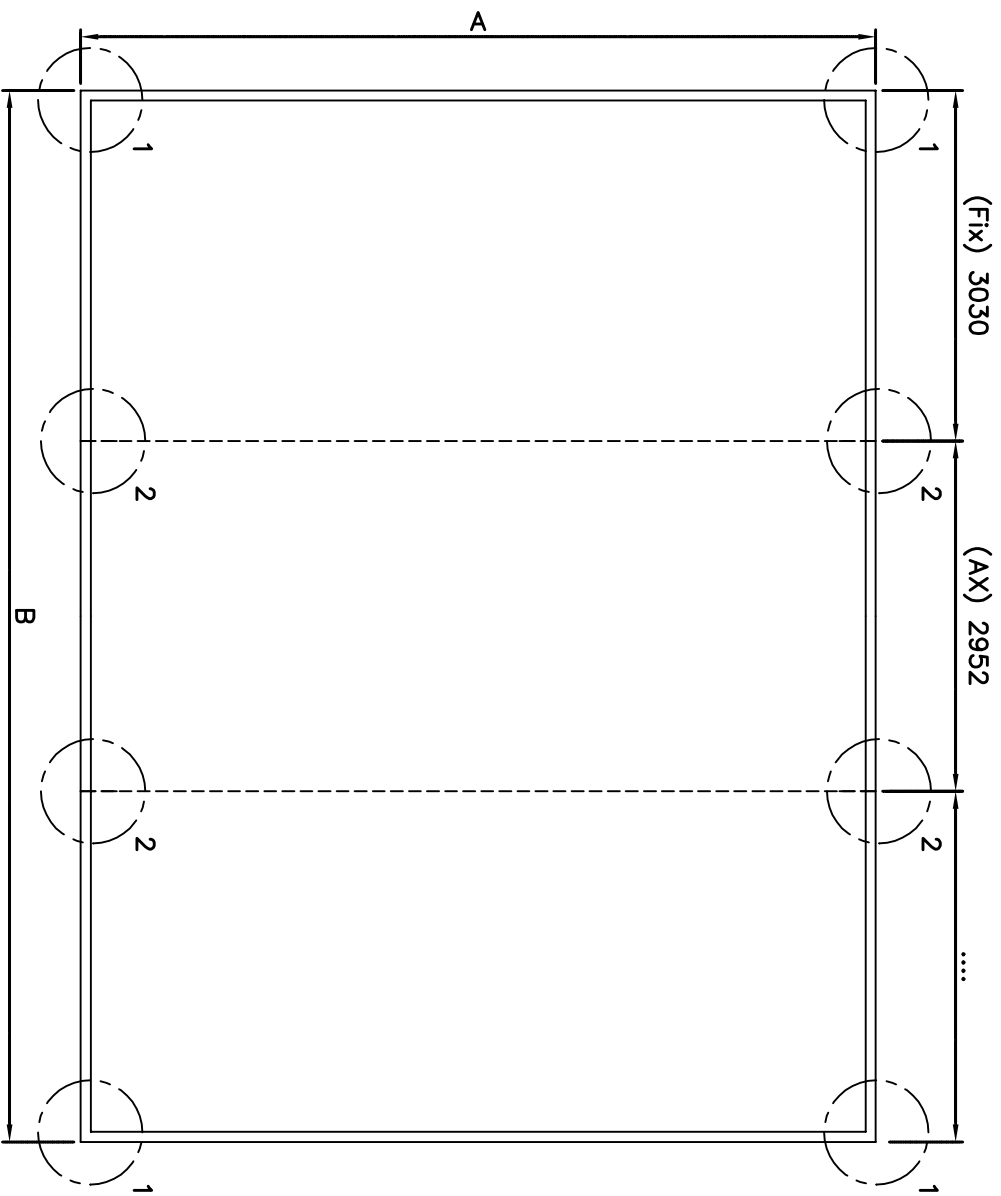

A	X	B
4574		4574
5312		5312
6050		6050
		6788
		7526
		8264
		9002

Detail-1

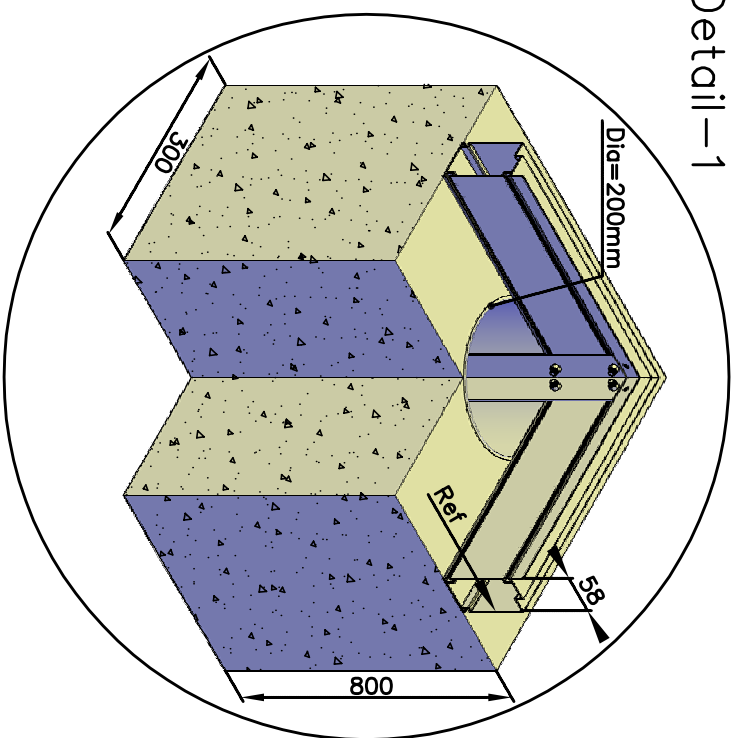

Detail-2

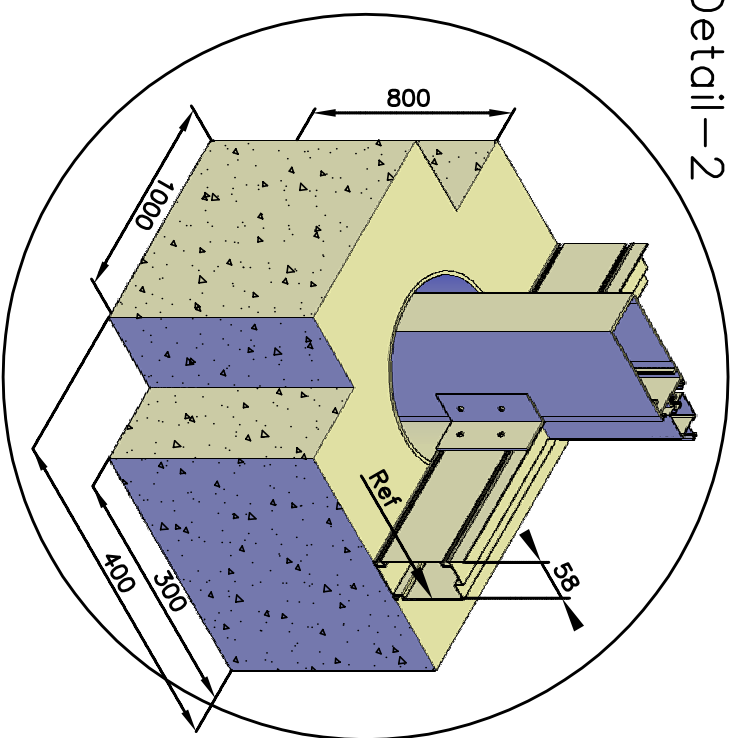

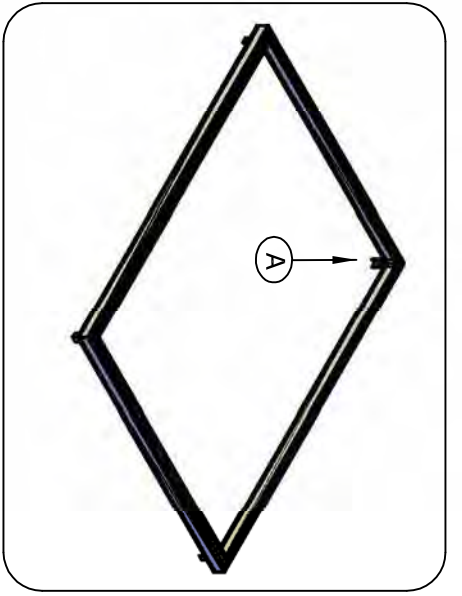

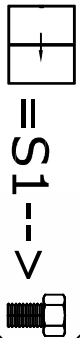
 = S1 --->

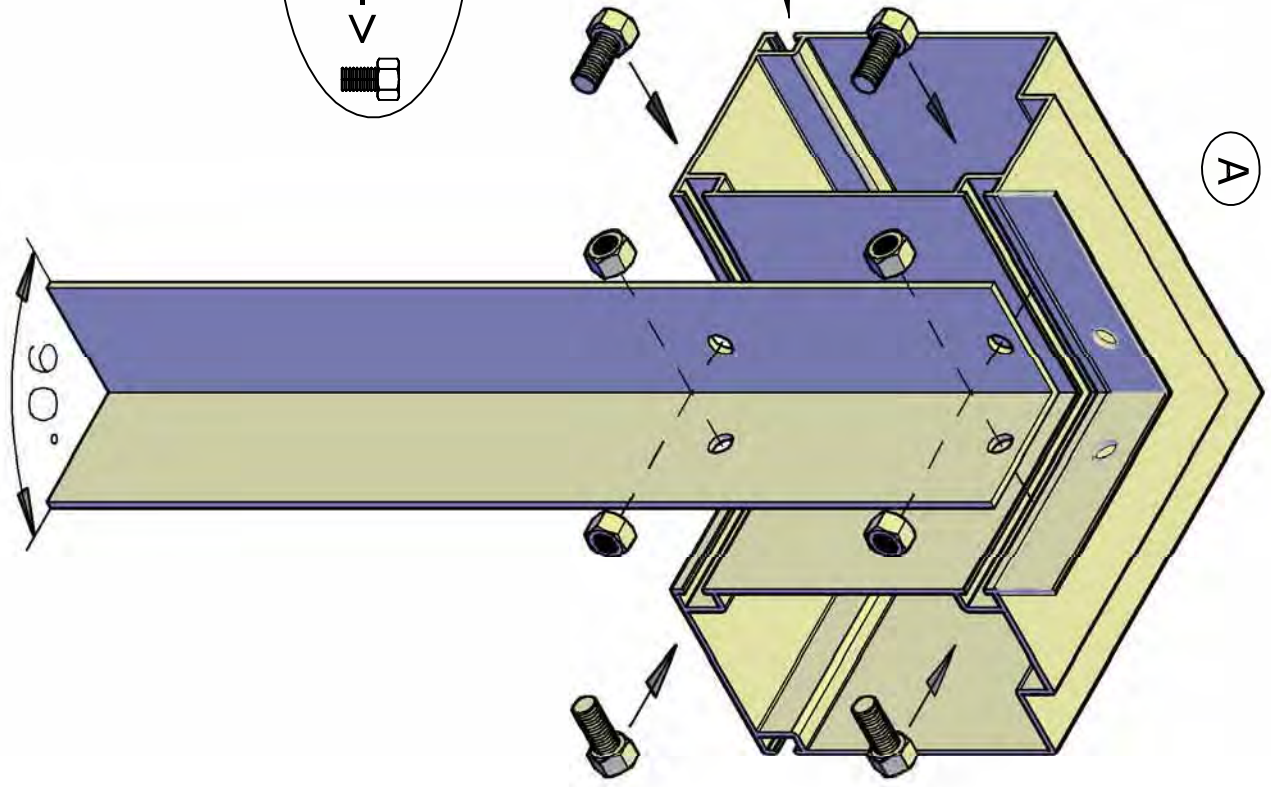

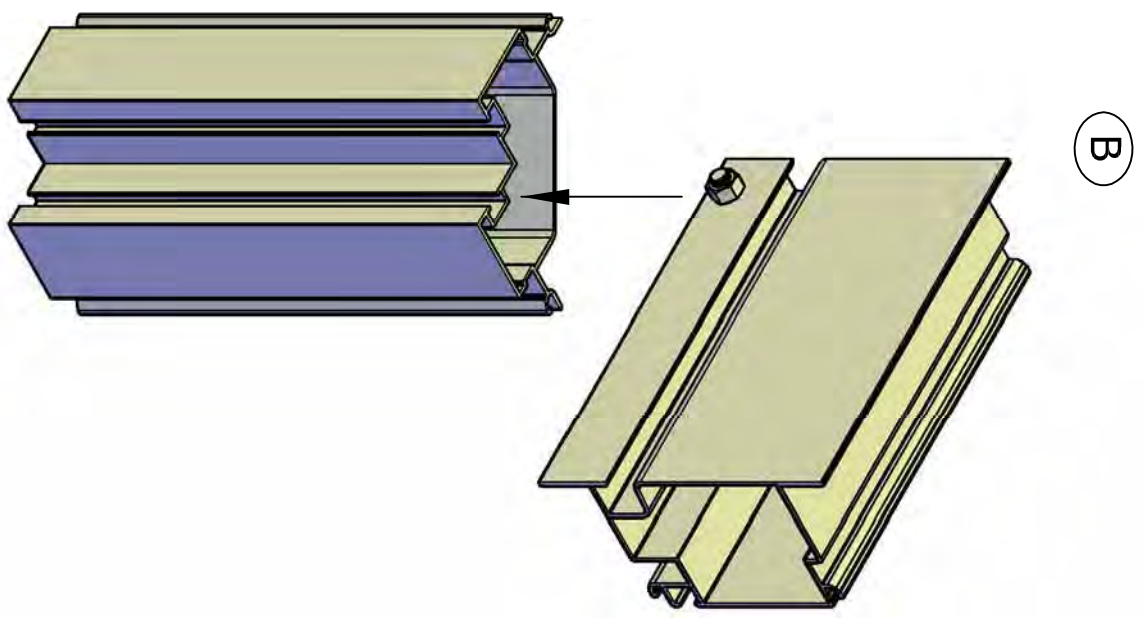
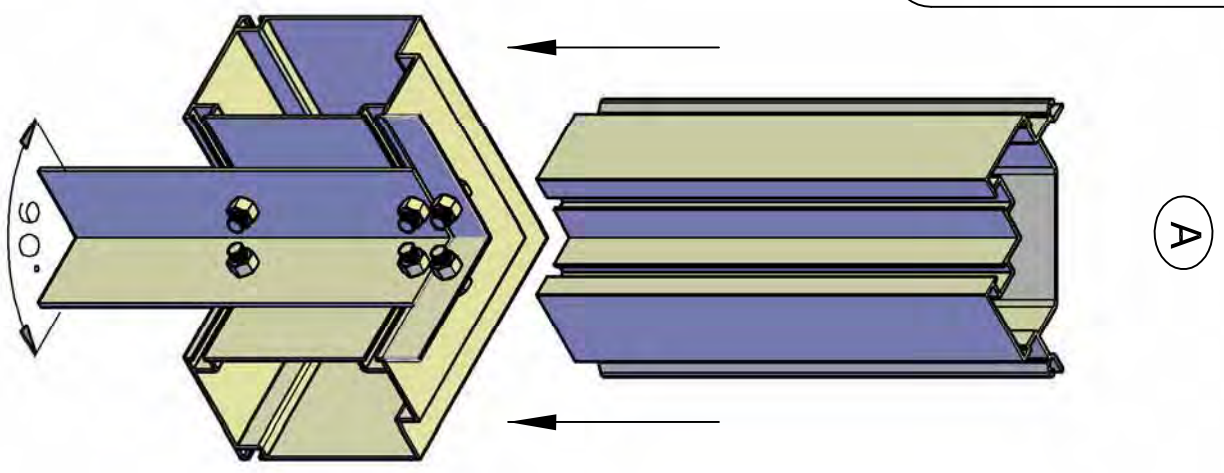
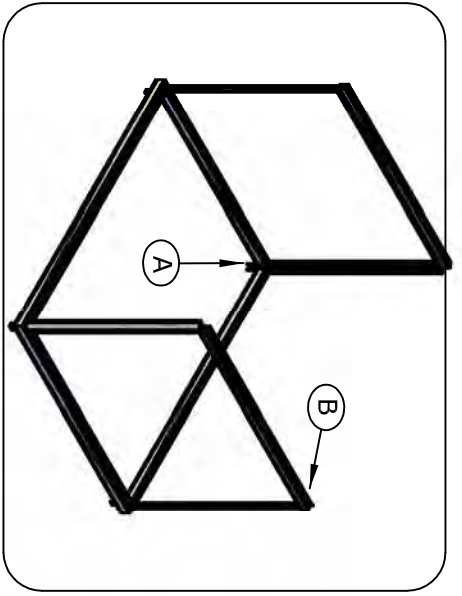

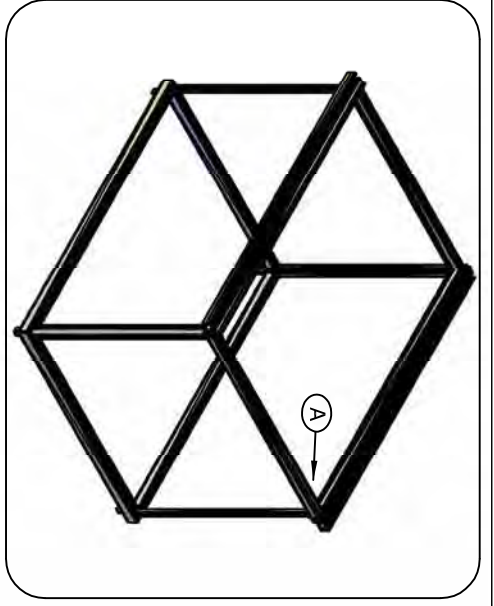

A

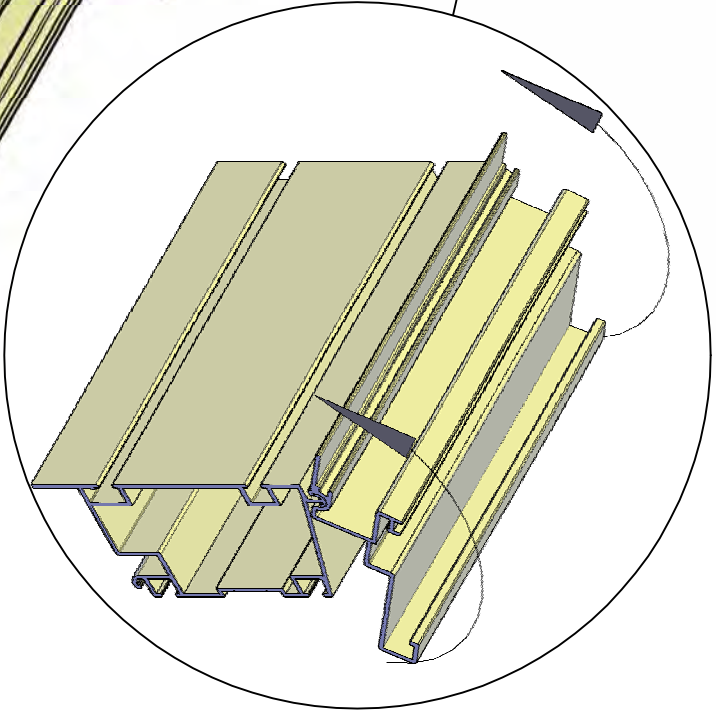
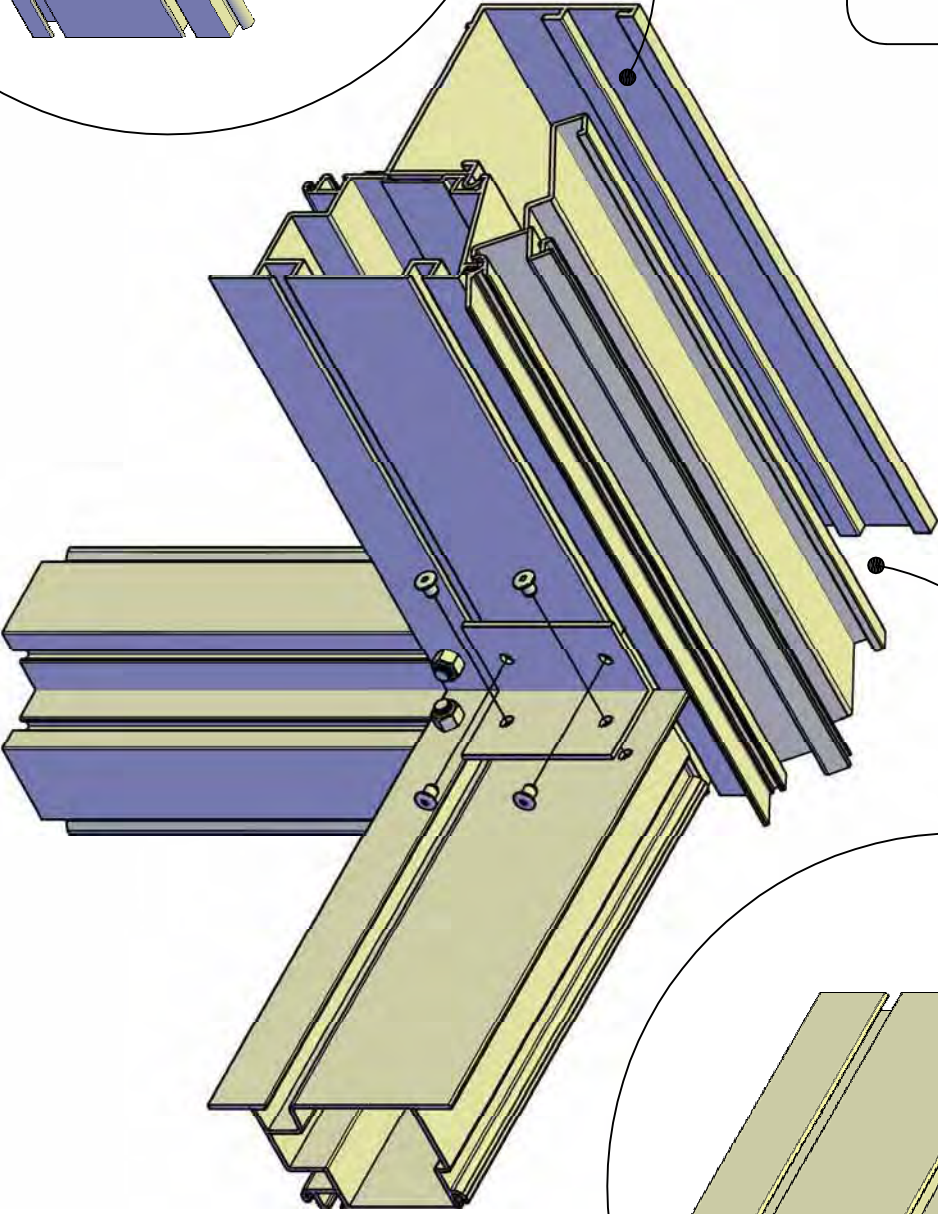
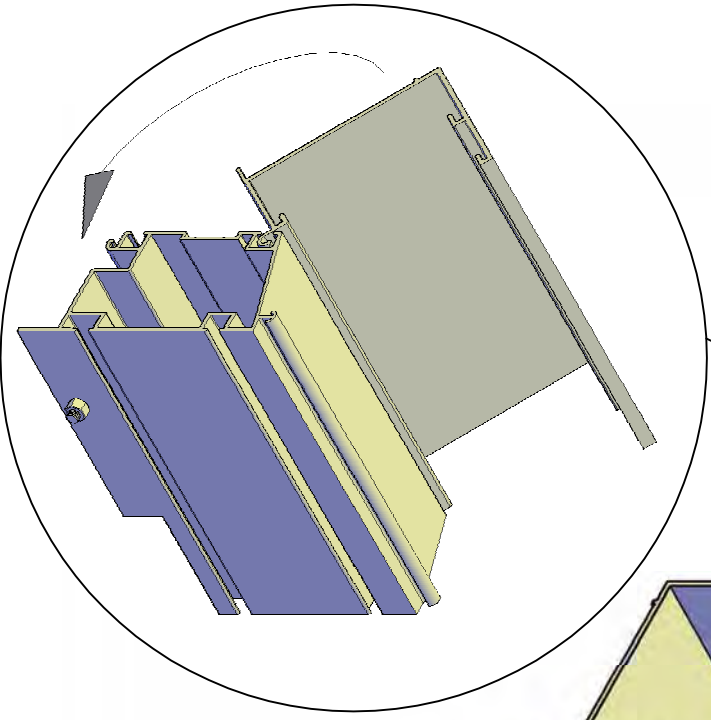

ii	Schufdeur-Porte Couliissante-Schiebetür-Sliding door	=S1
	Skydedør-Skyvedør-Skuggväv-Porta scorrevole	
ii	Schufraam-Fenêtre Couliissante-Schiebefenster-Sliding window	=SR1
	Skydevindue-Skyvetönster-Skuggvindue-Finestra scorrevole	

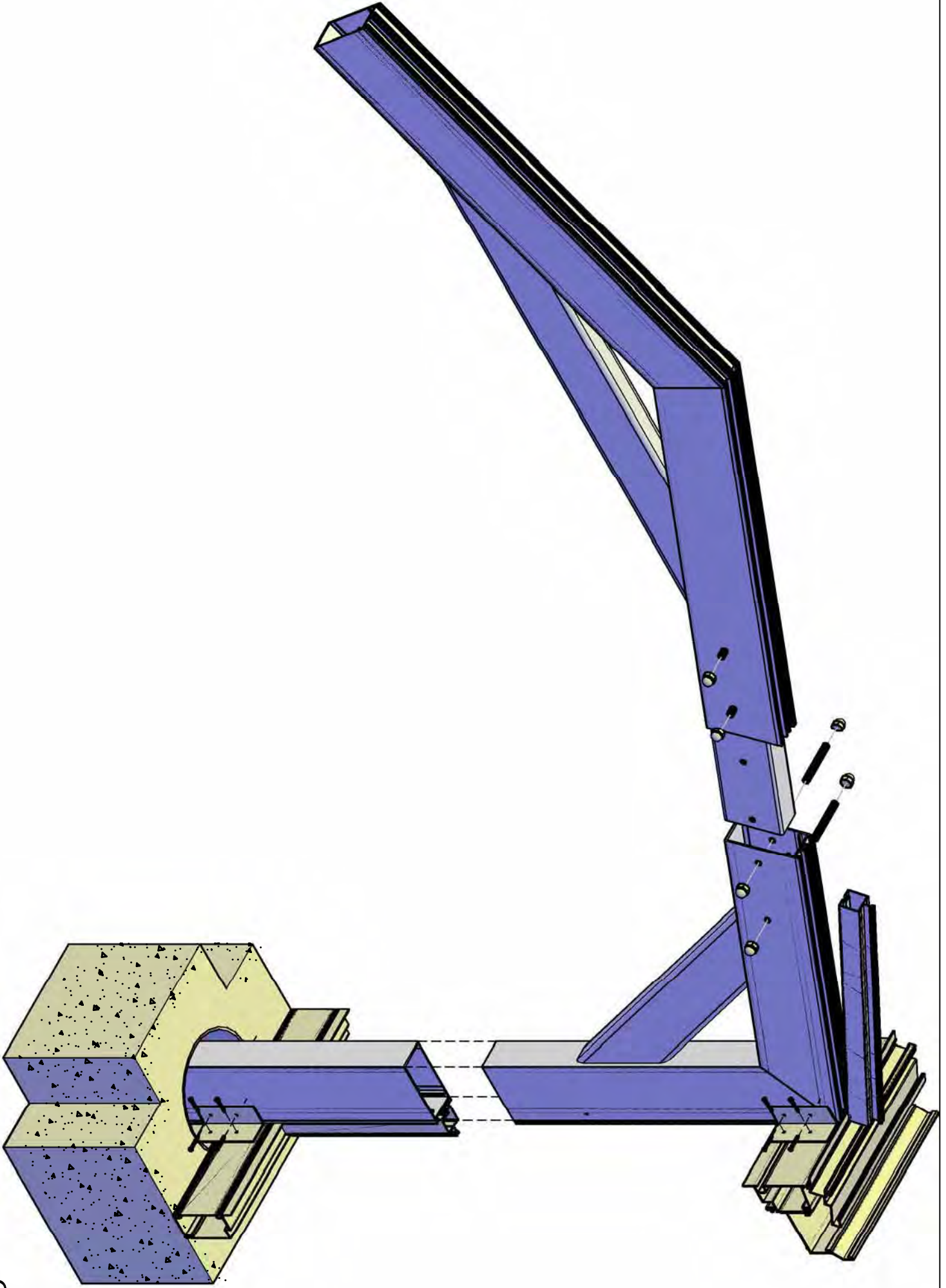

G4

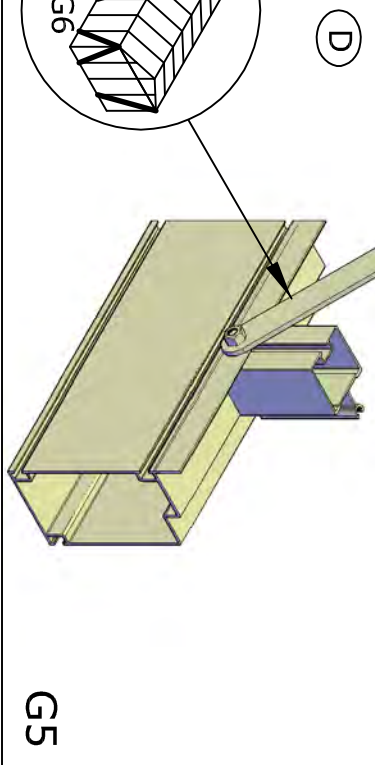
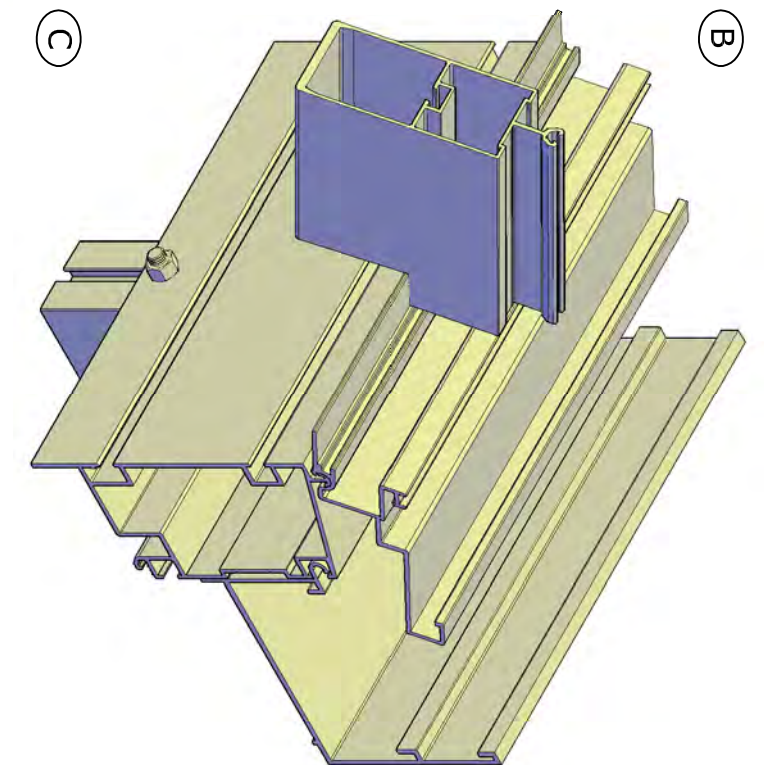
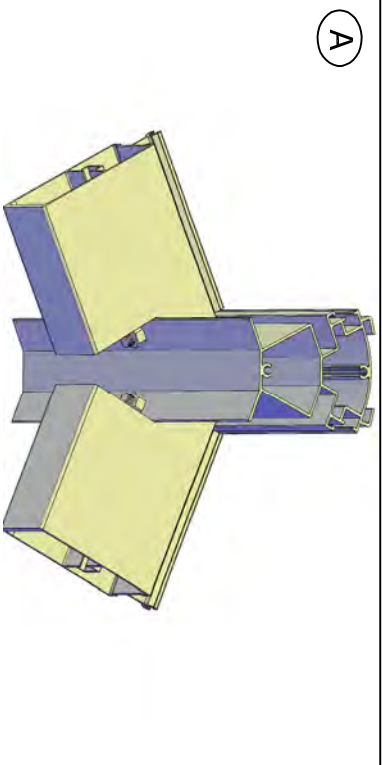
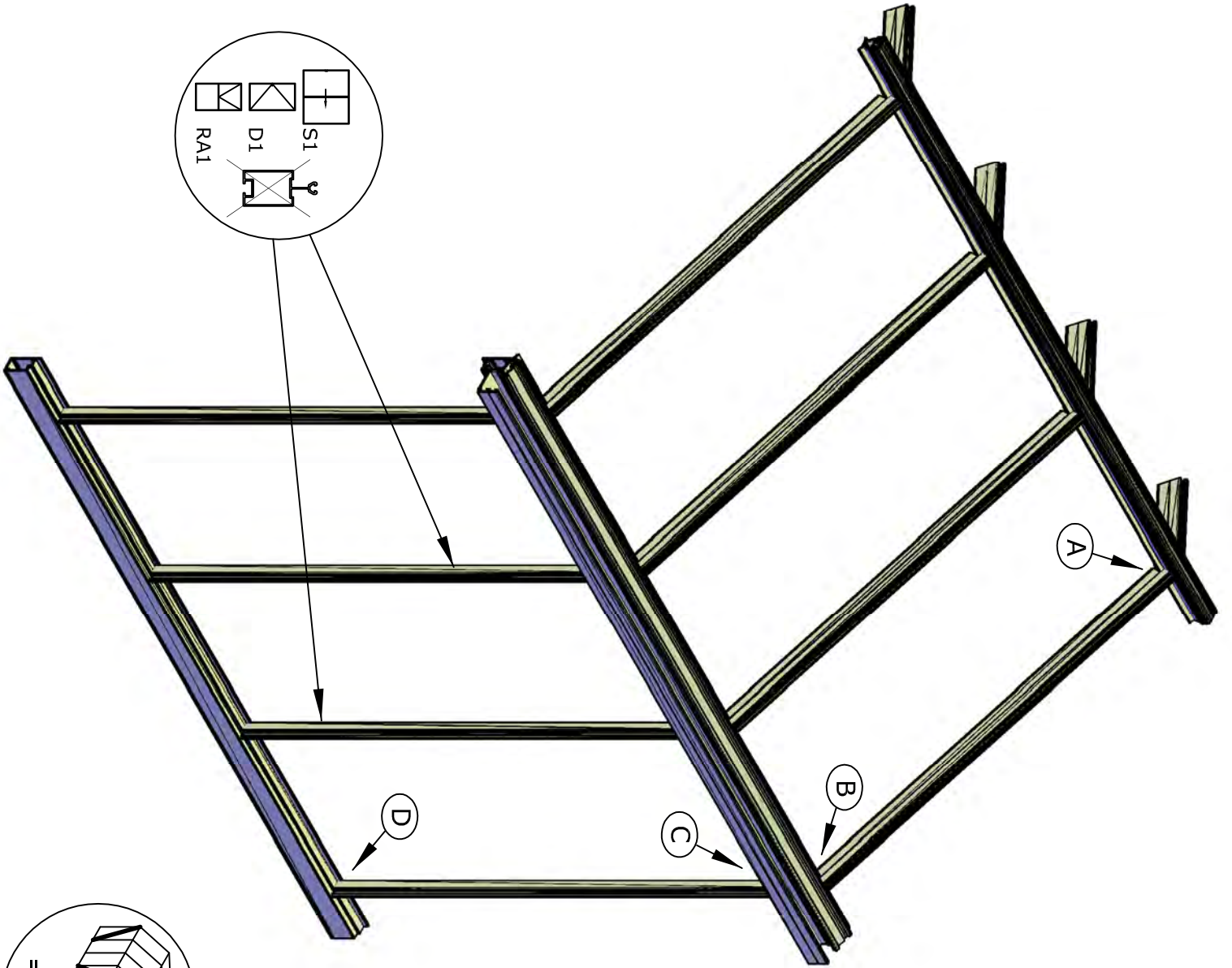

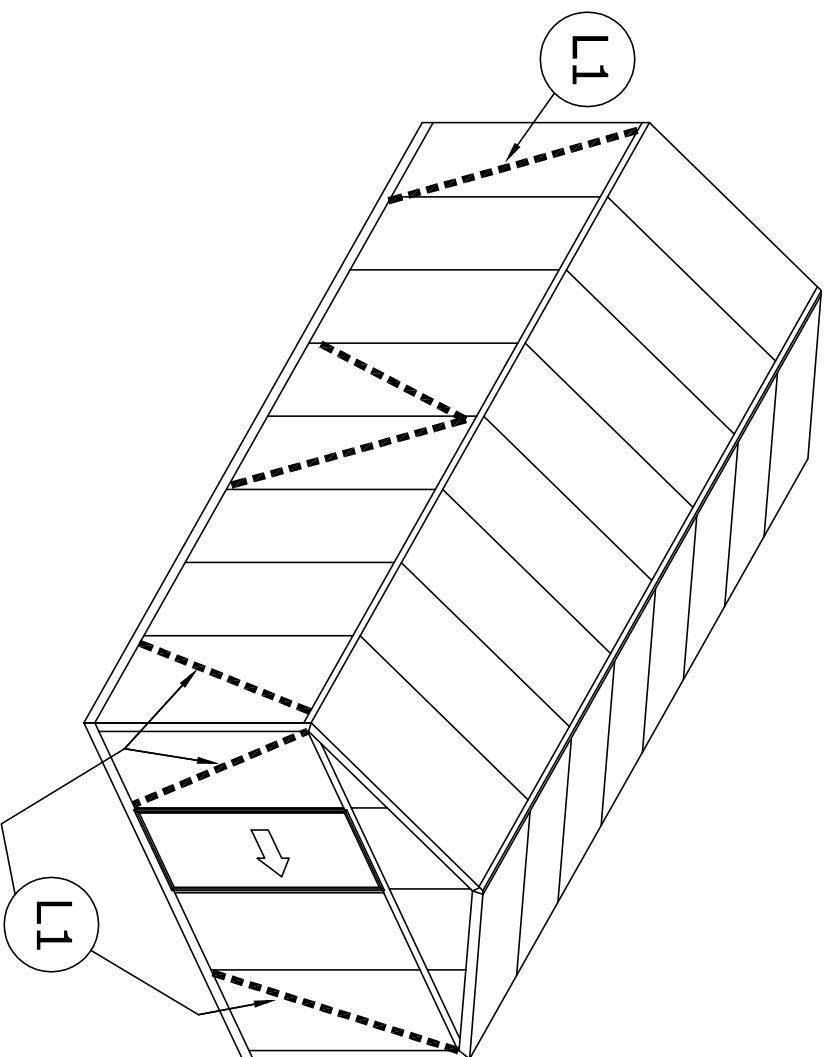

L1 = 1975mm

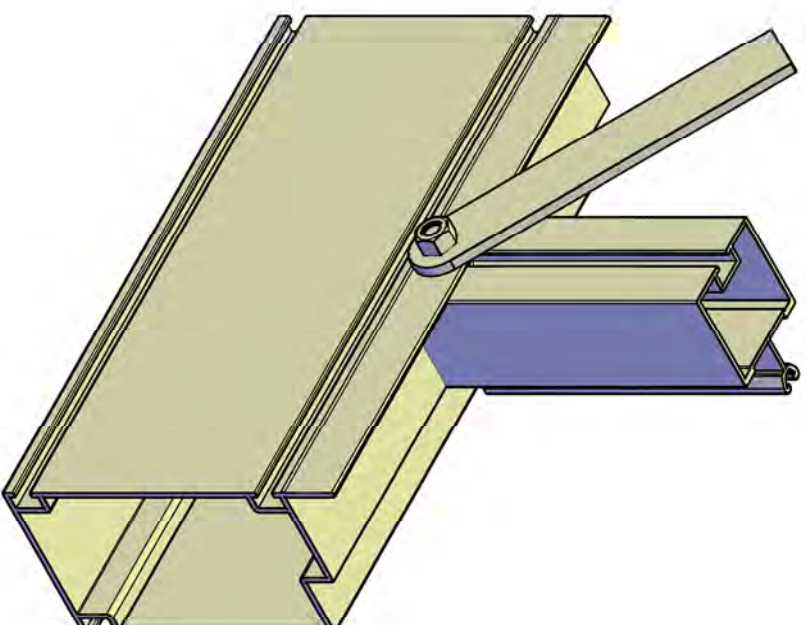

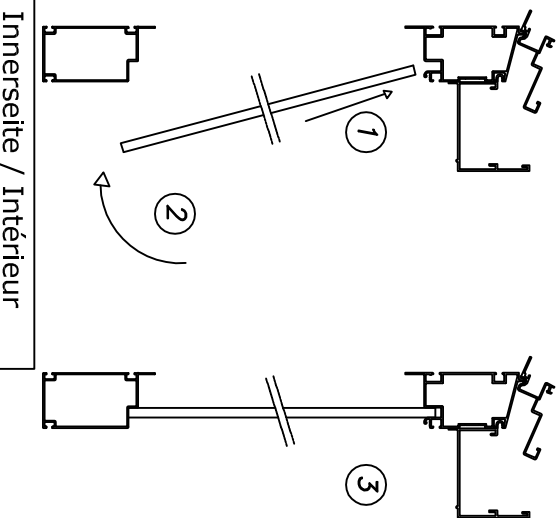
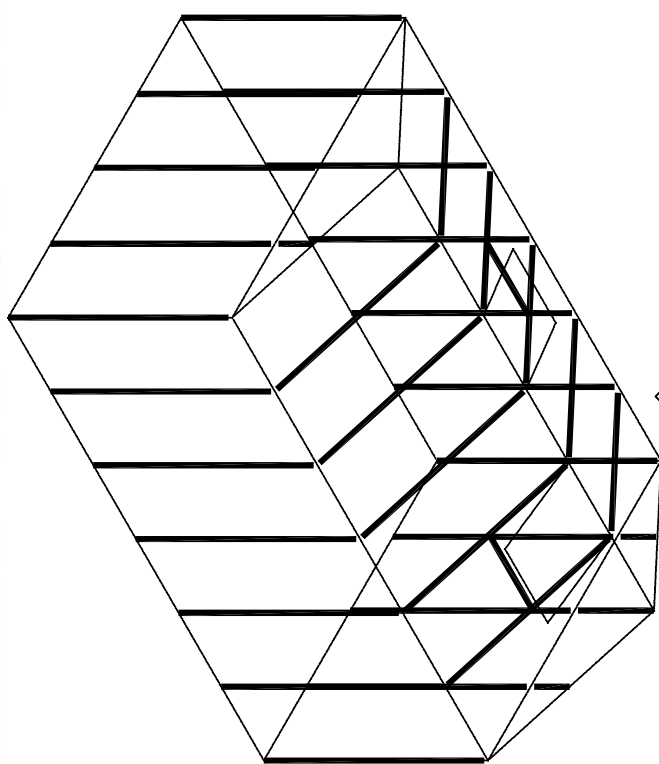
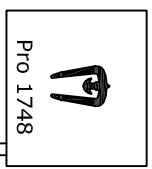
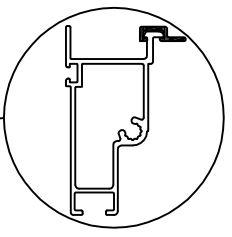
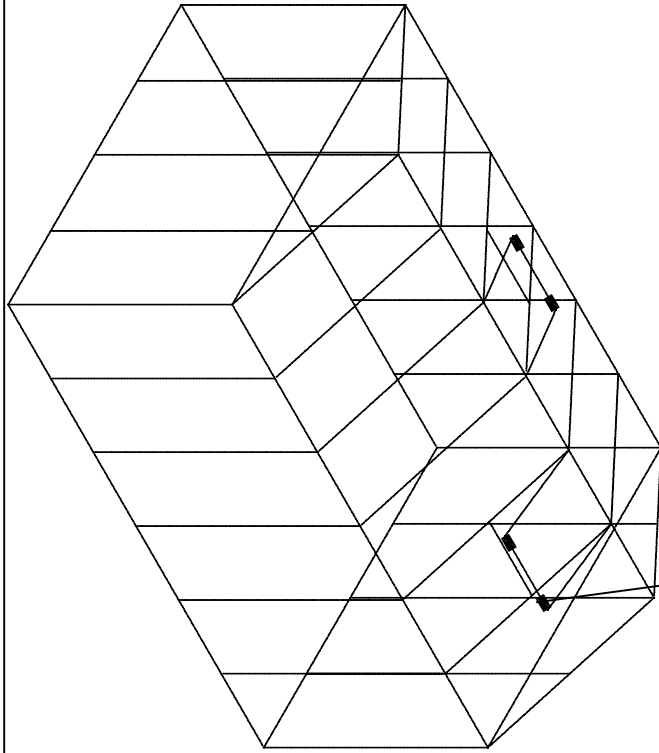
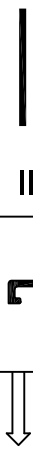

!!! K-glas: ● = Inside / Innerseite / Intérieur

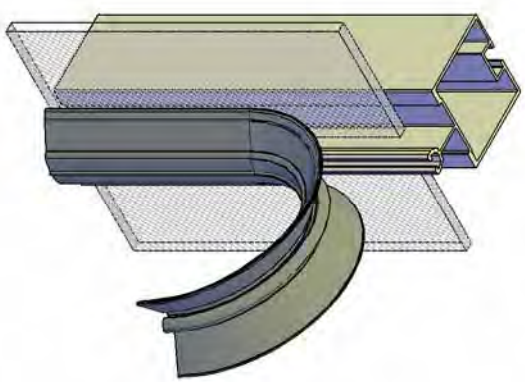

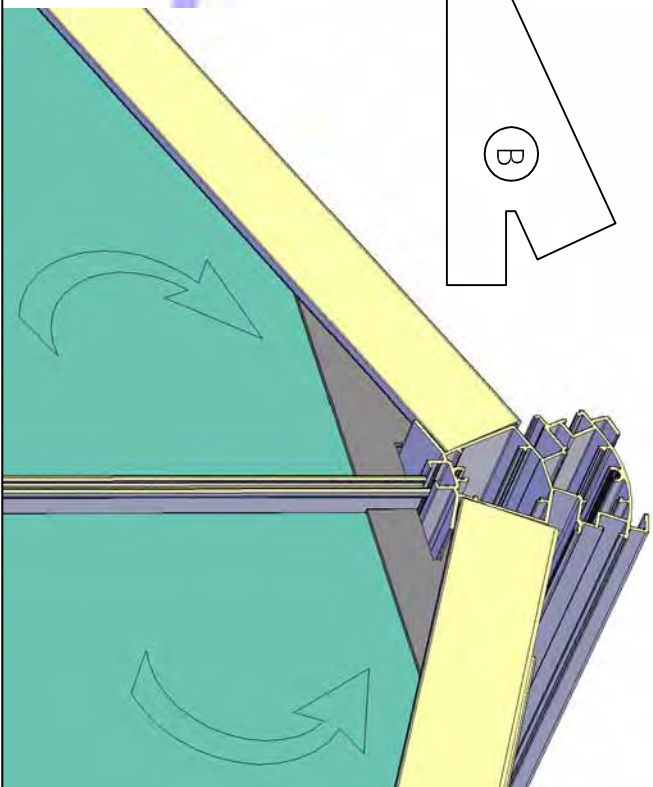
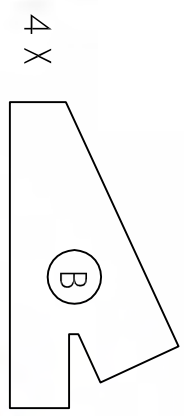
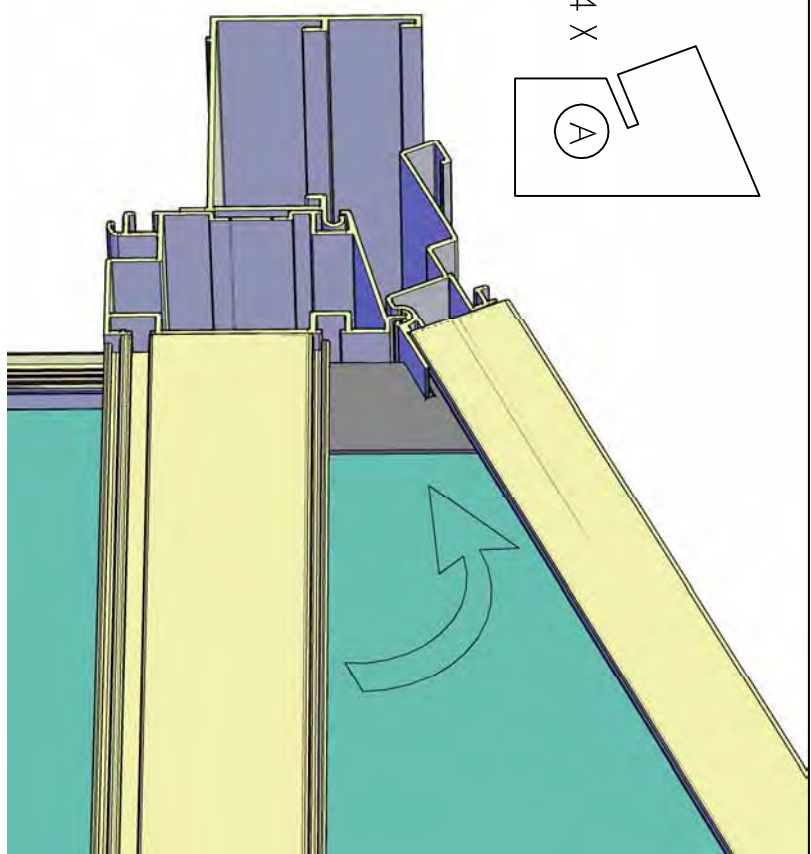
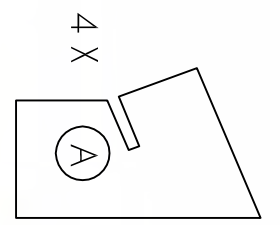
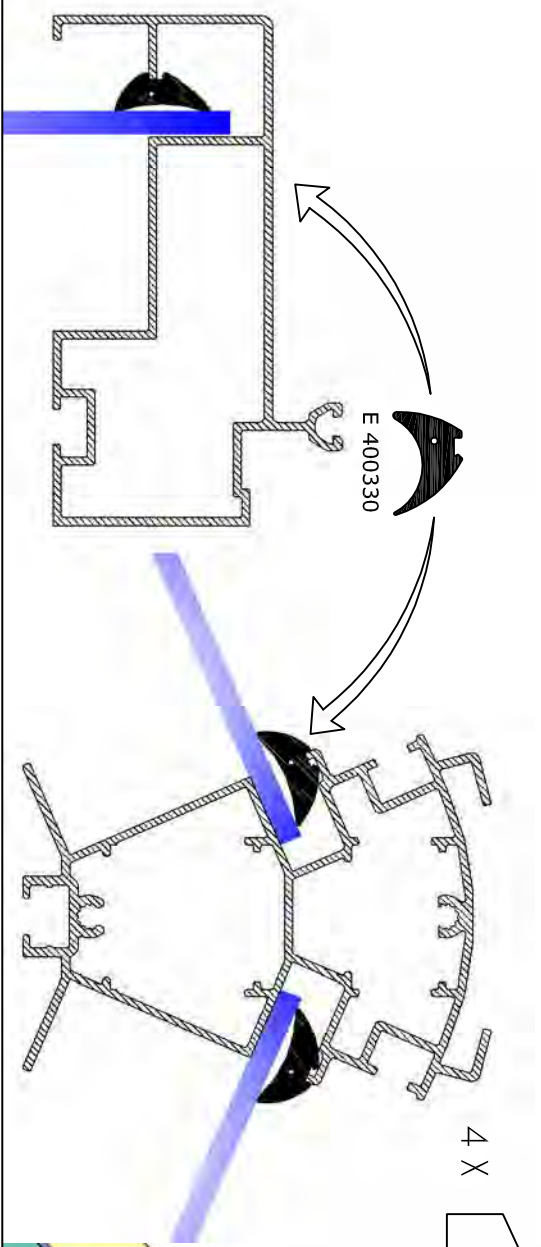
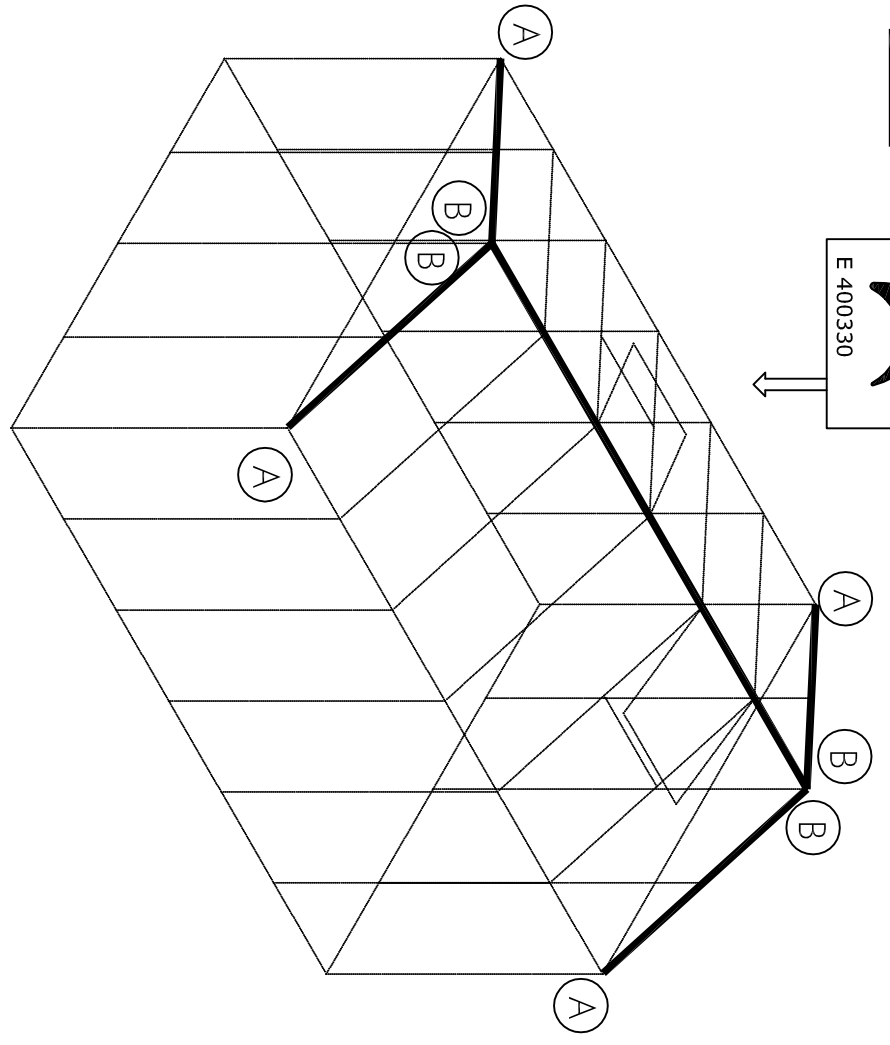
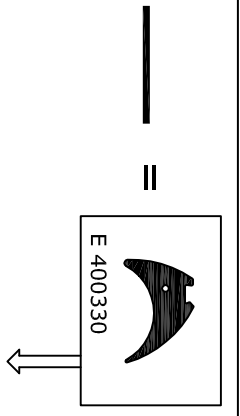

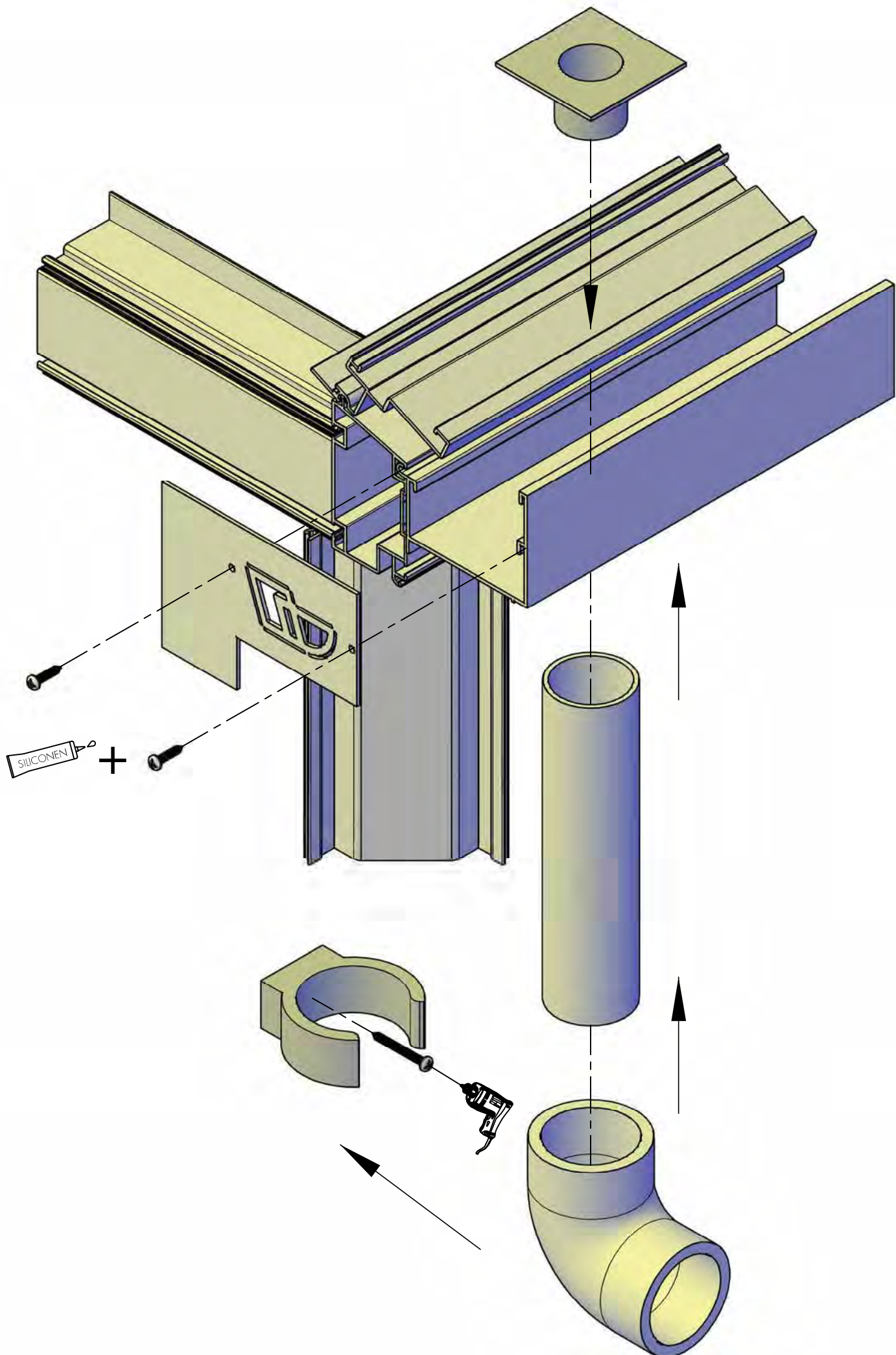

ORANGERIE

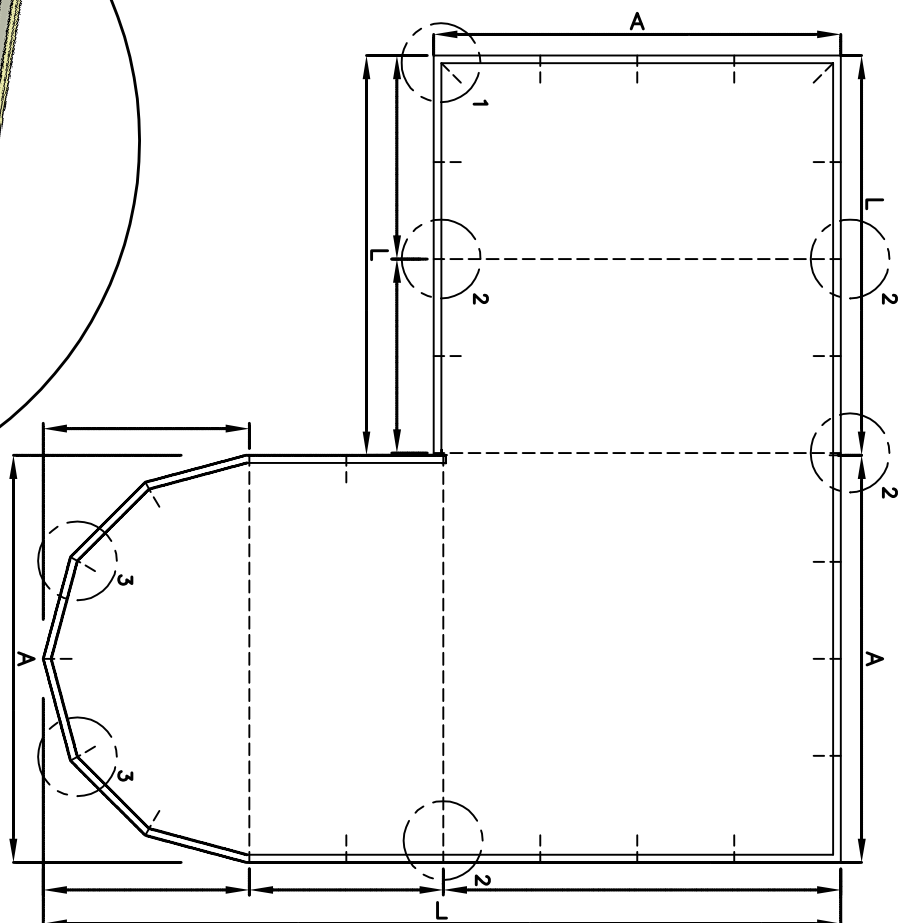

Detail-3

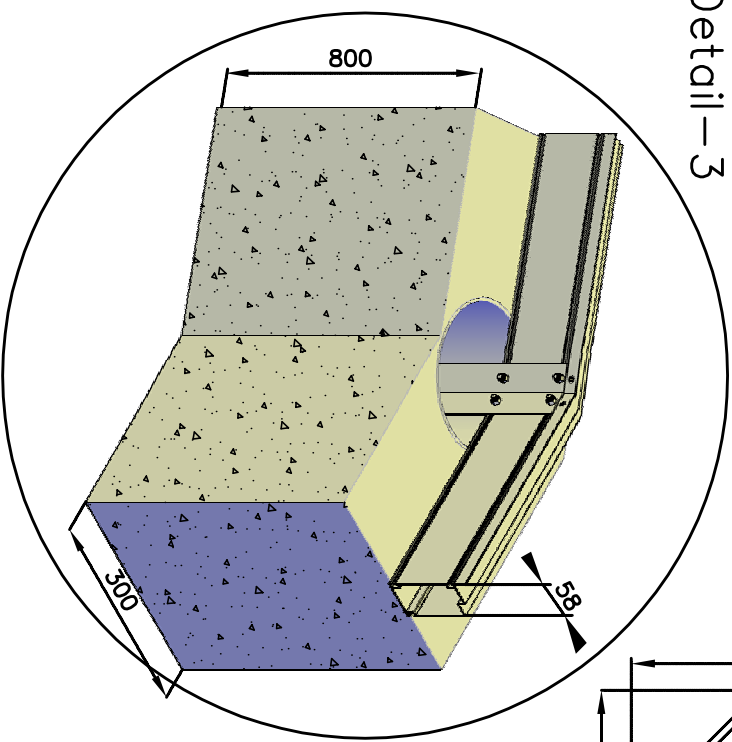

Detail-1

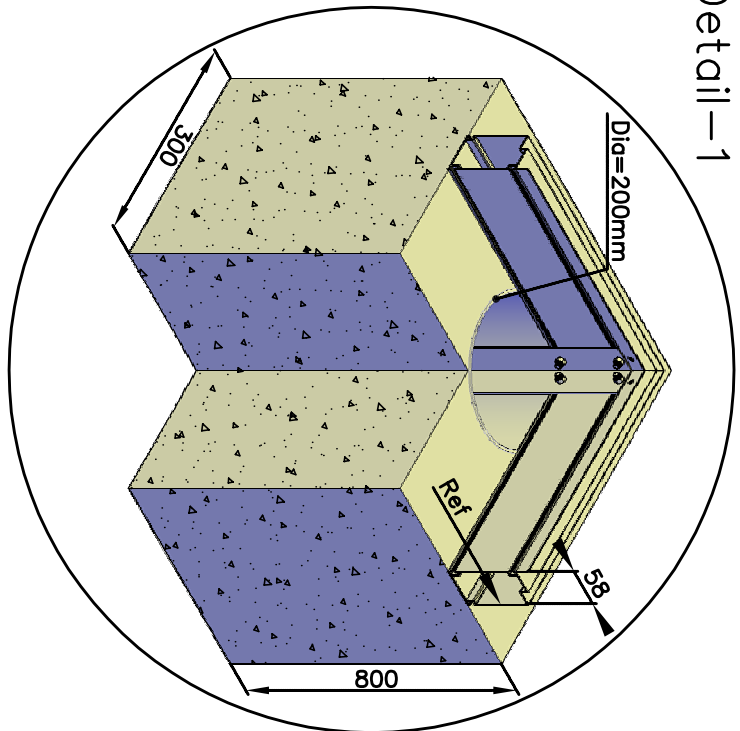

Detail-2

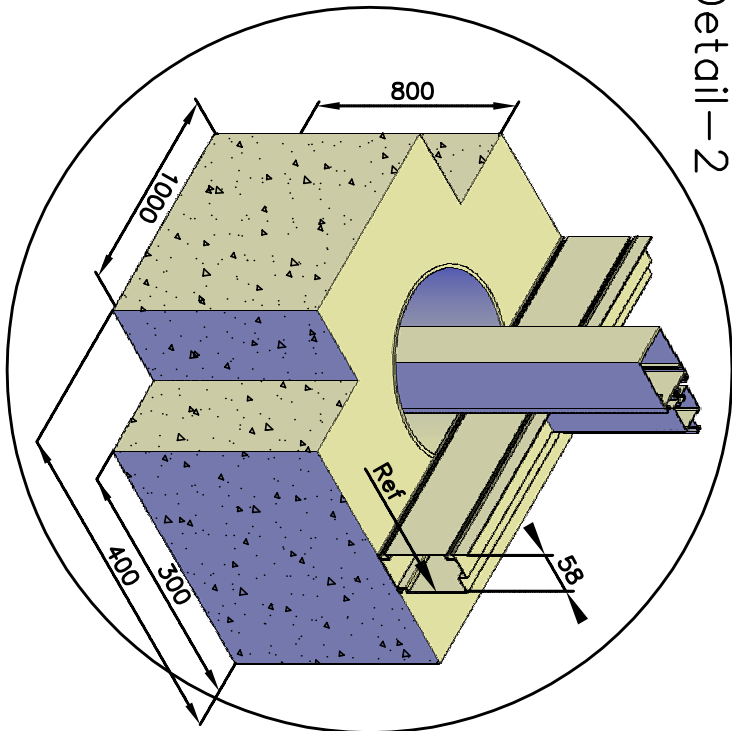

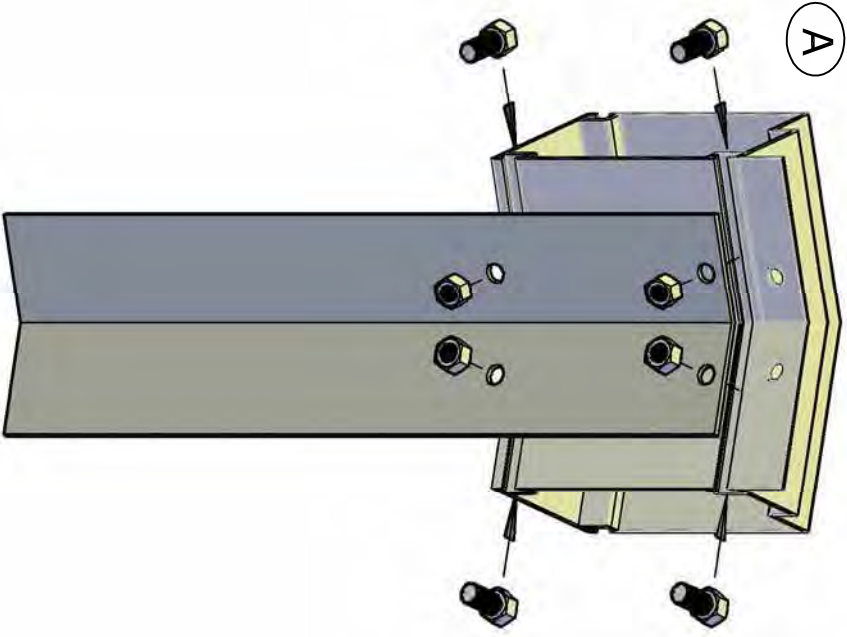
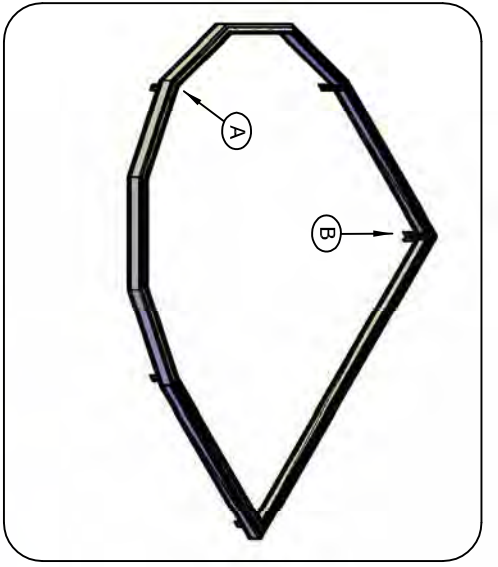

B

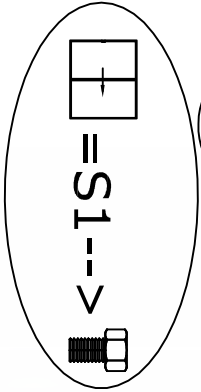
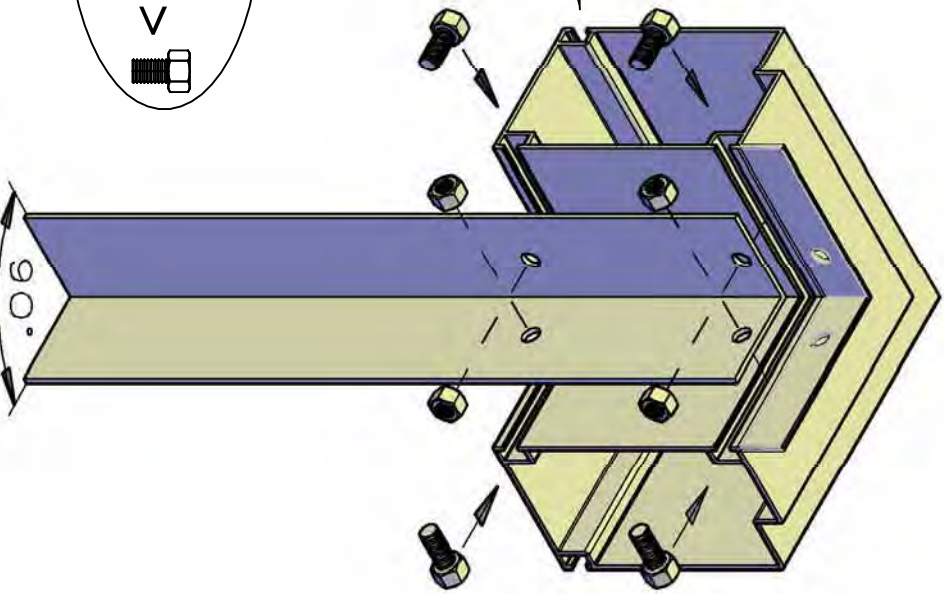

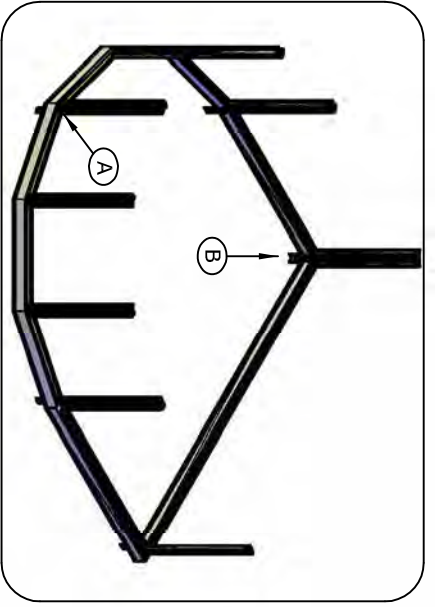

A

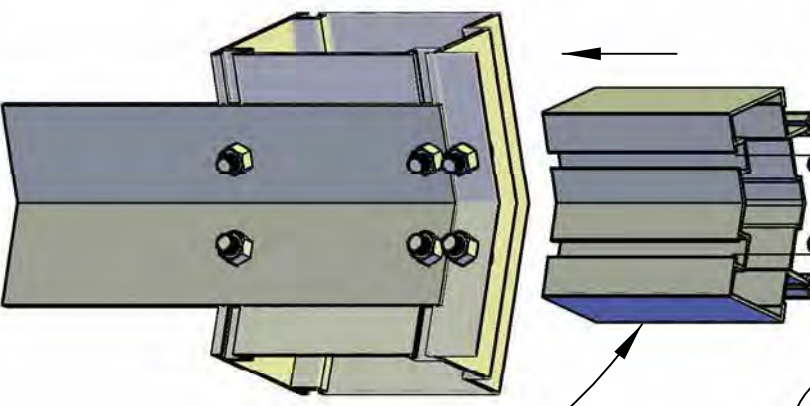
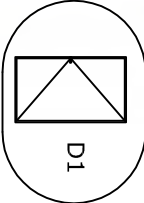
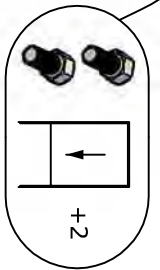

B

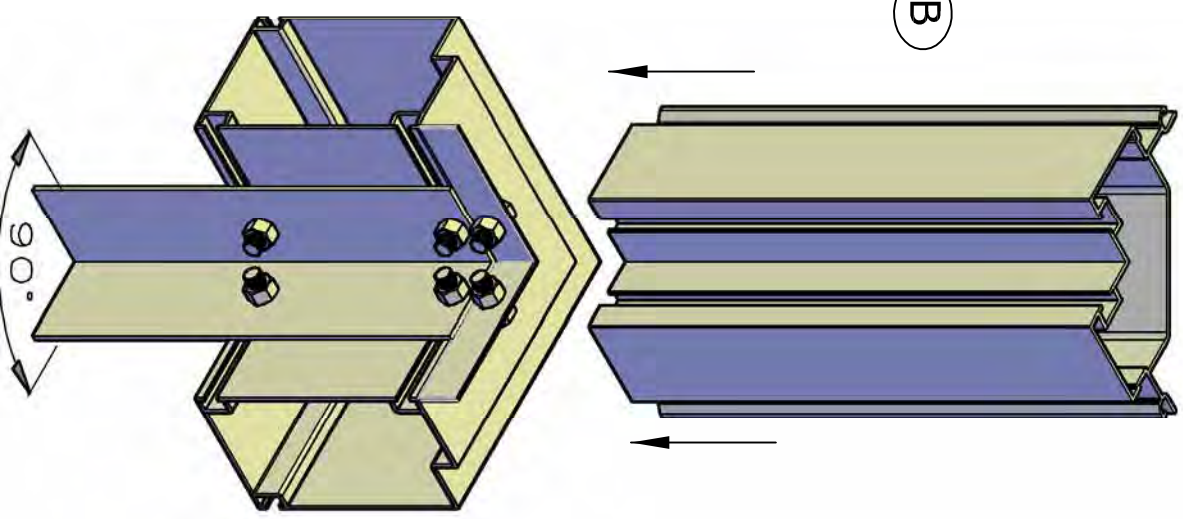

OR2

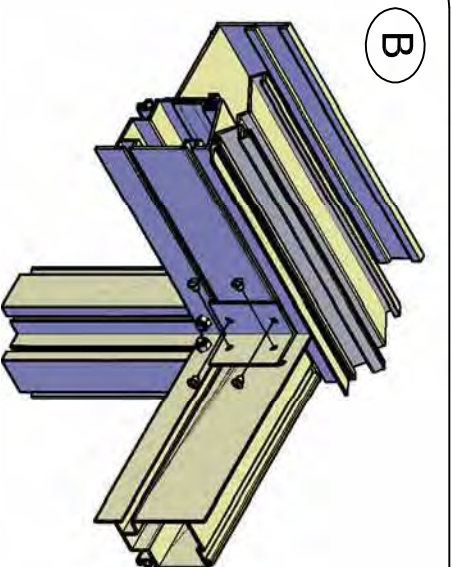
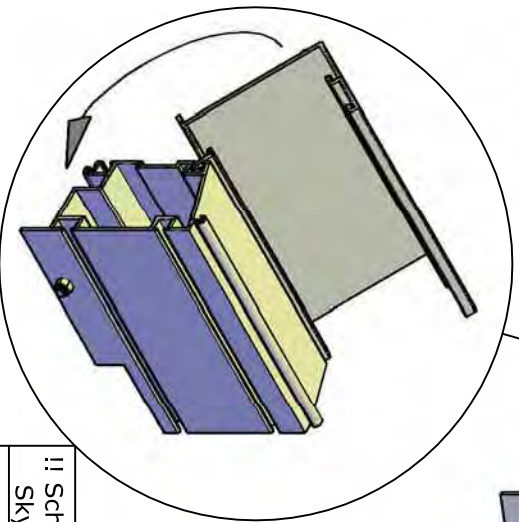
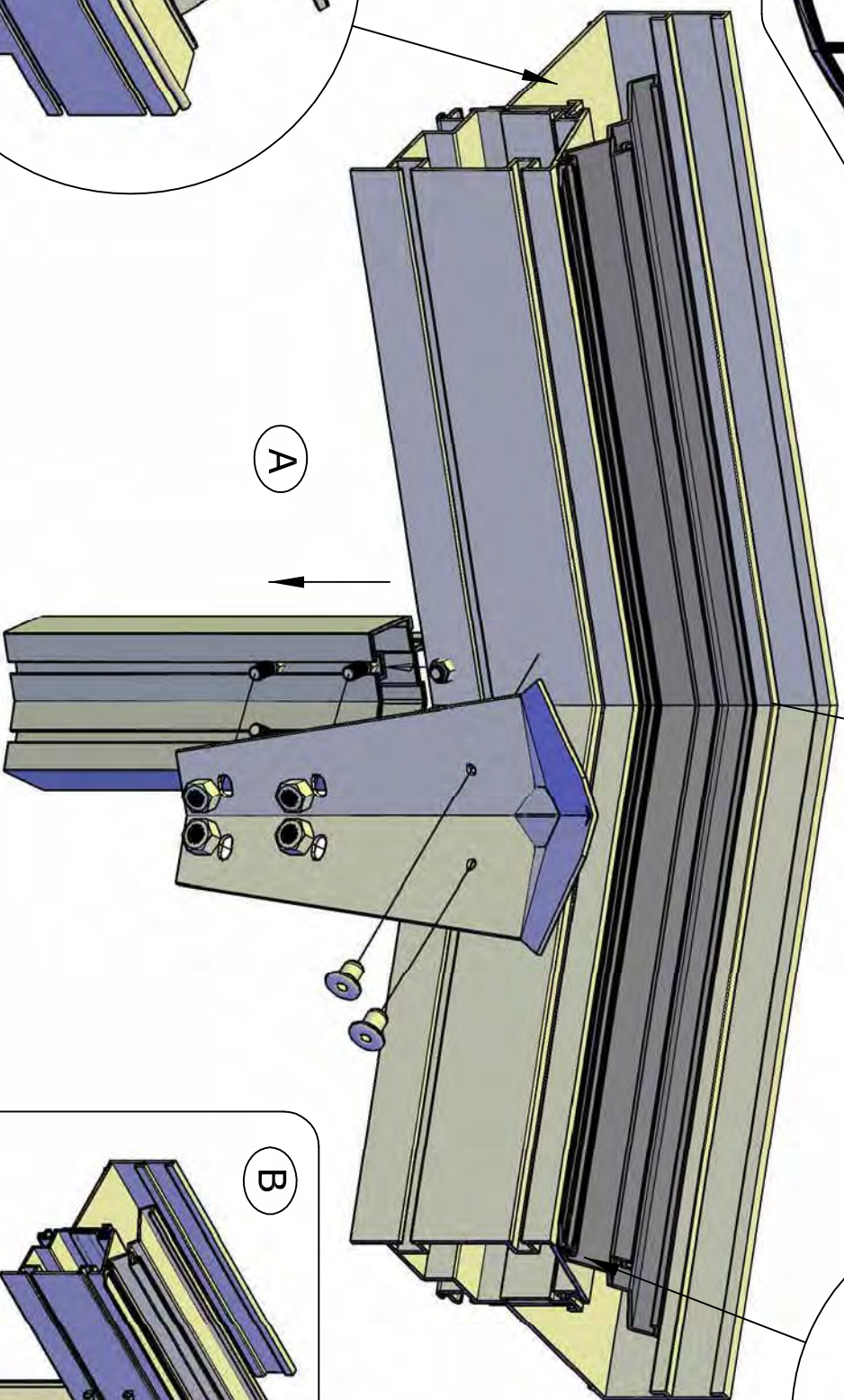
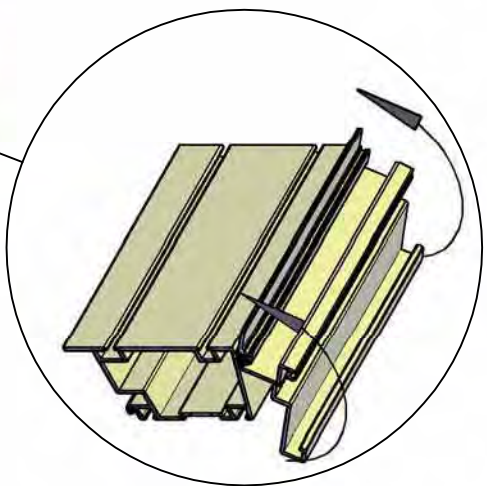
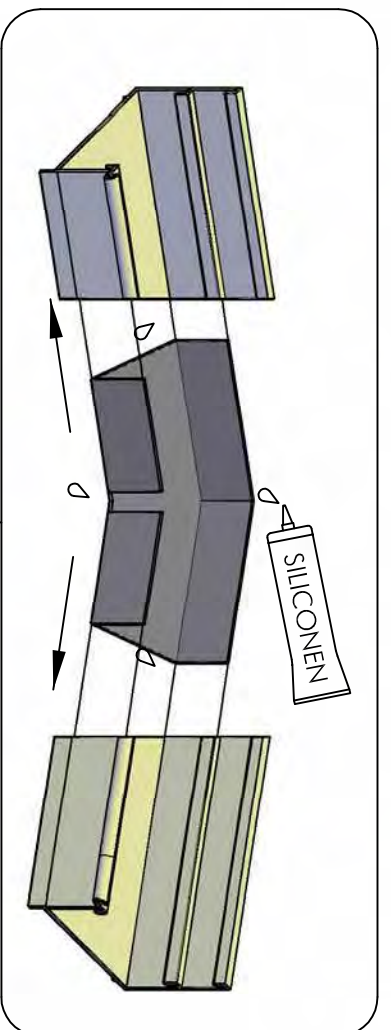
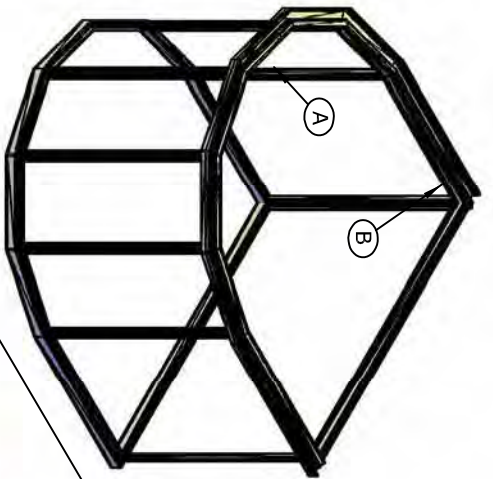

ii Schuifdeur-Porte Couliissante-Schiebetür-Sliding door =S1
 ii Skydedør-Skyvedør-Skuggväv-Porta scorrevole
 ii Schuifraam-Fenêtre Couliissante-Schiebefenster-Sliding window =SR1
 ii Skydevindue-Skyvefönster-Skuggvindue-Finestra scorrevole

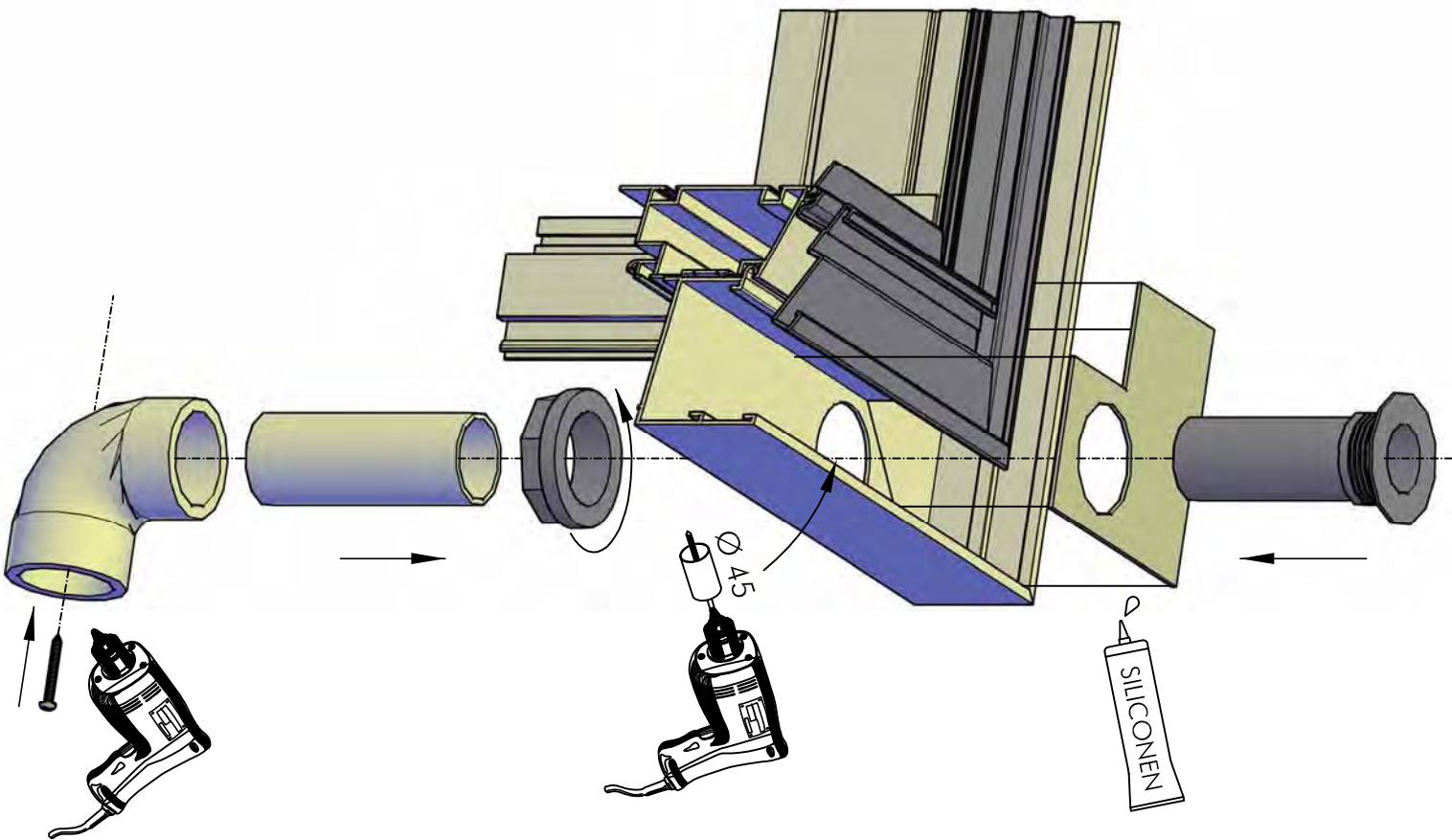
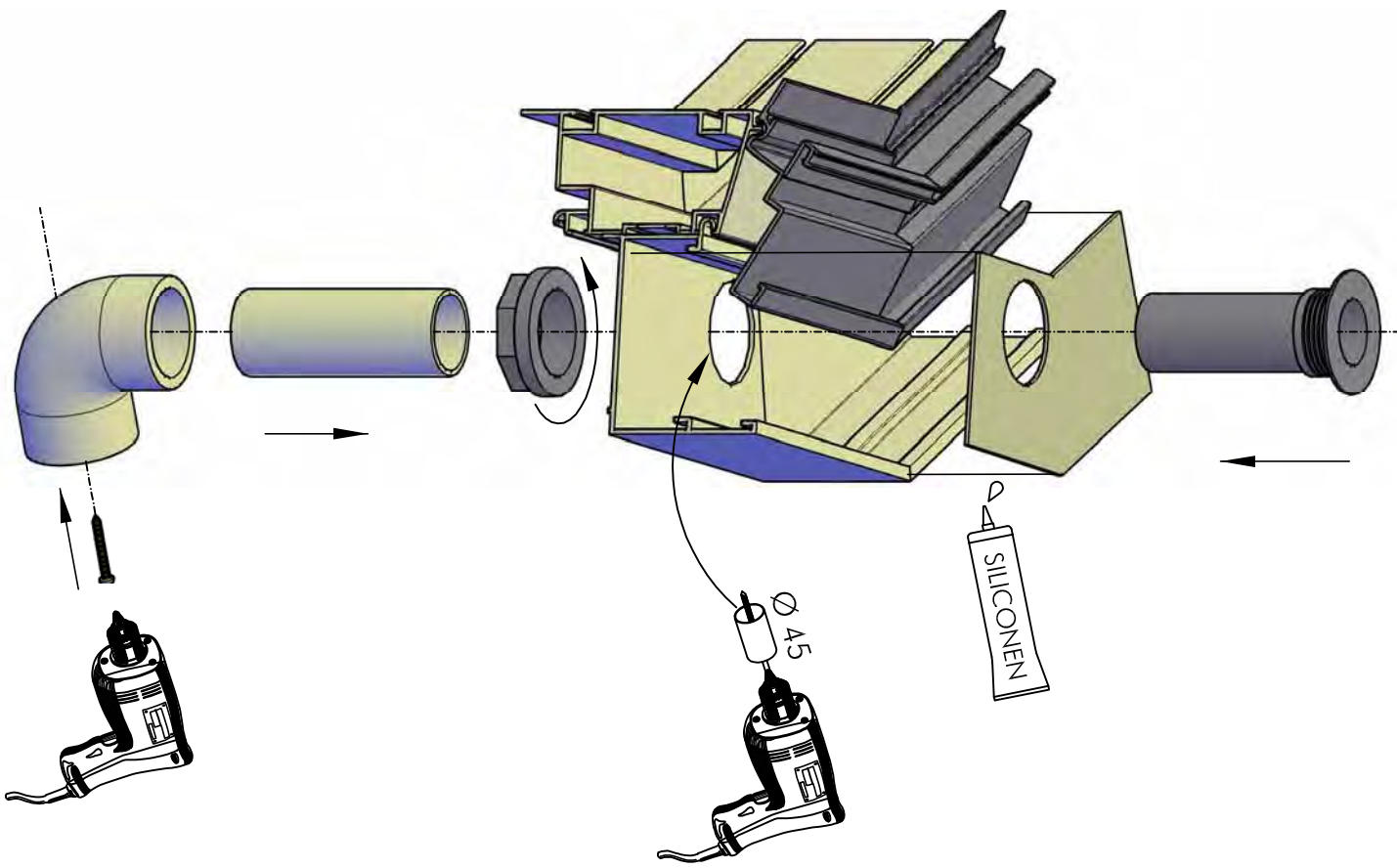

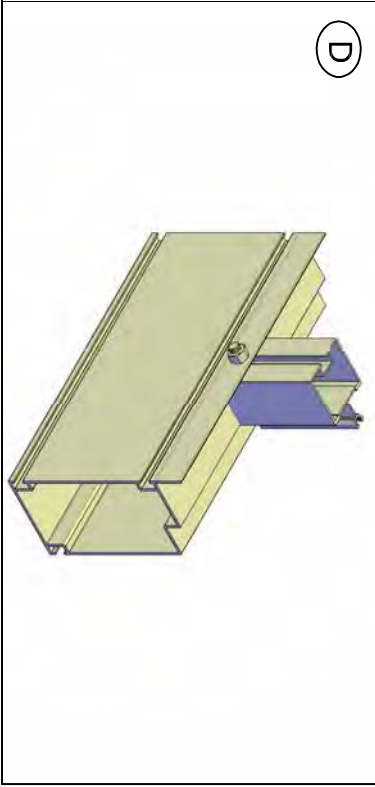
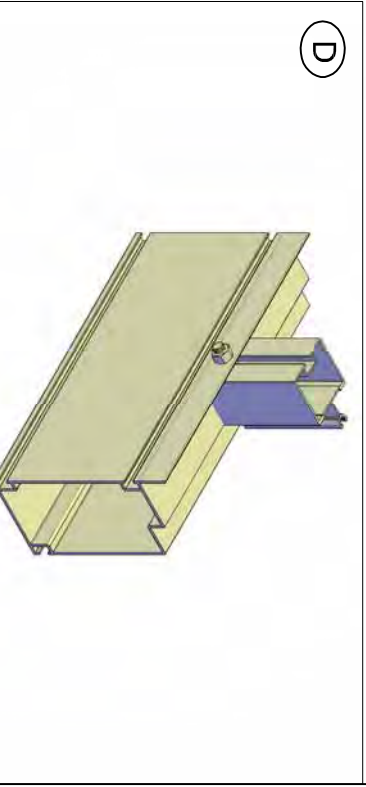
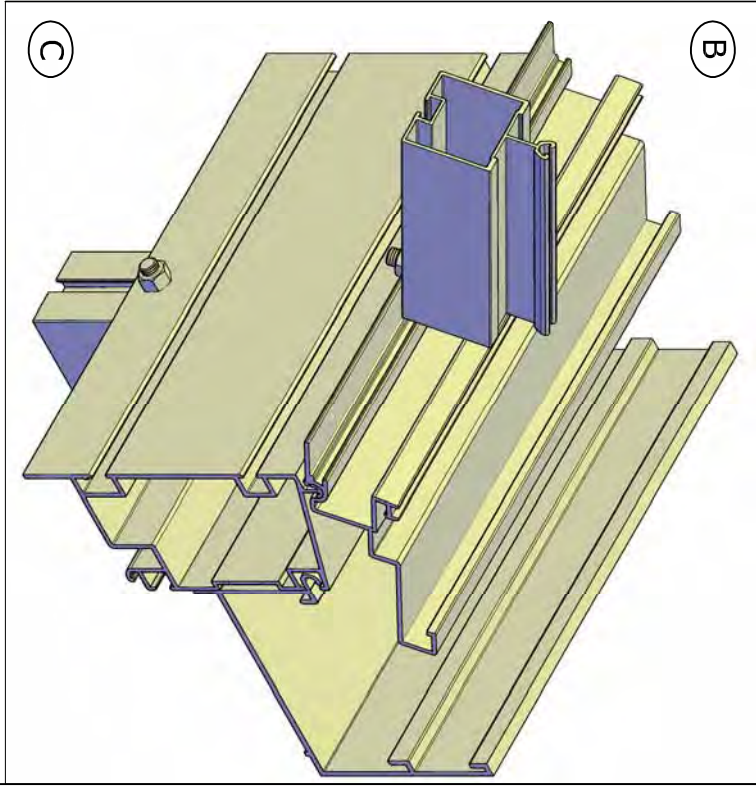
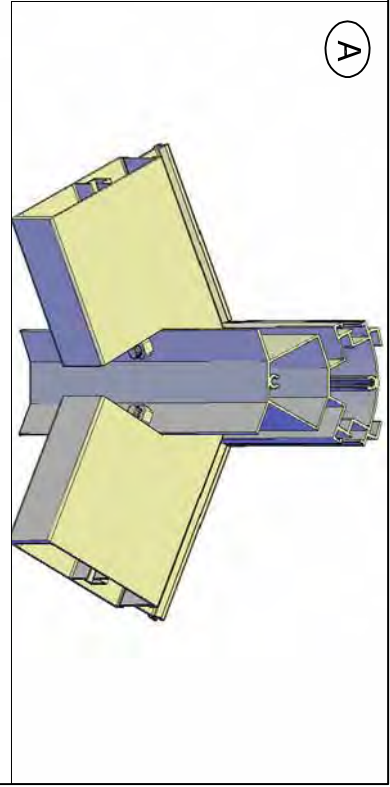
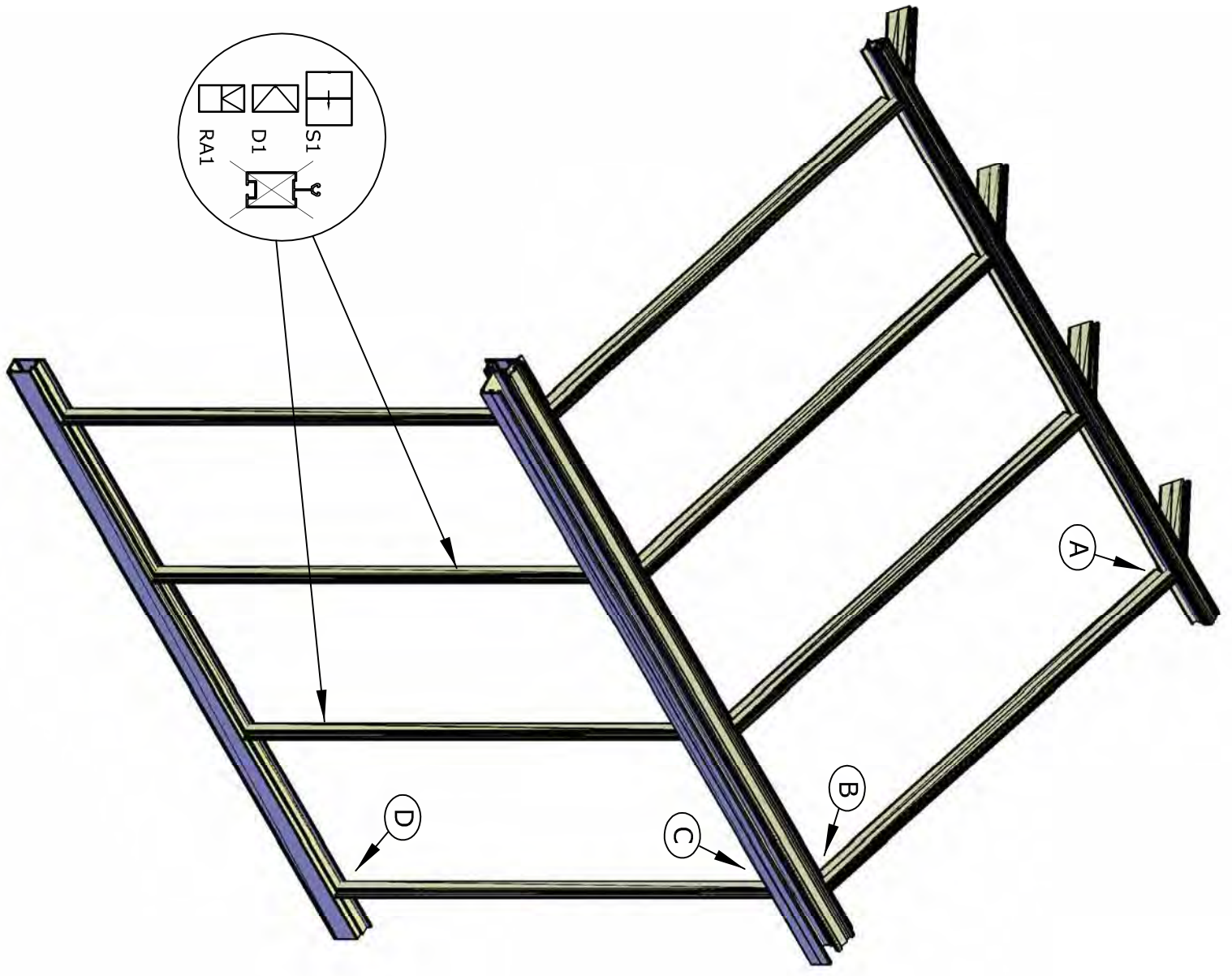

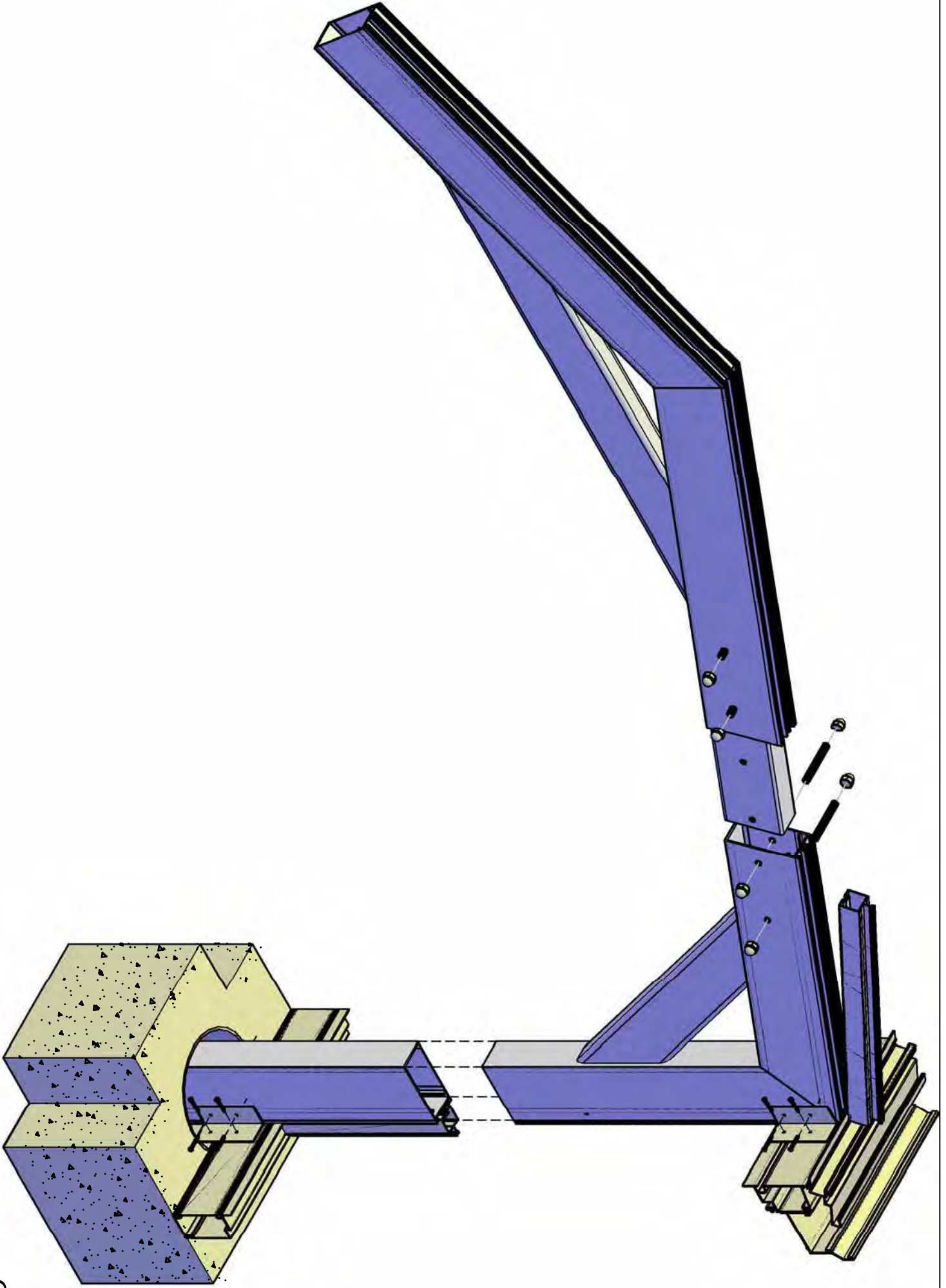

G4

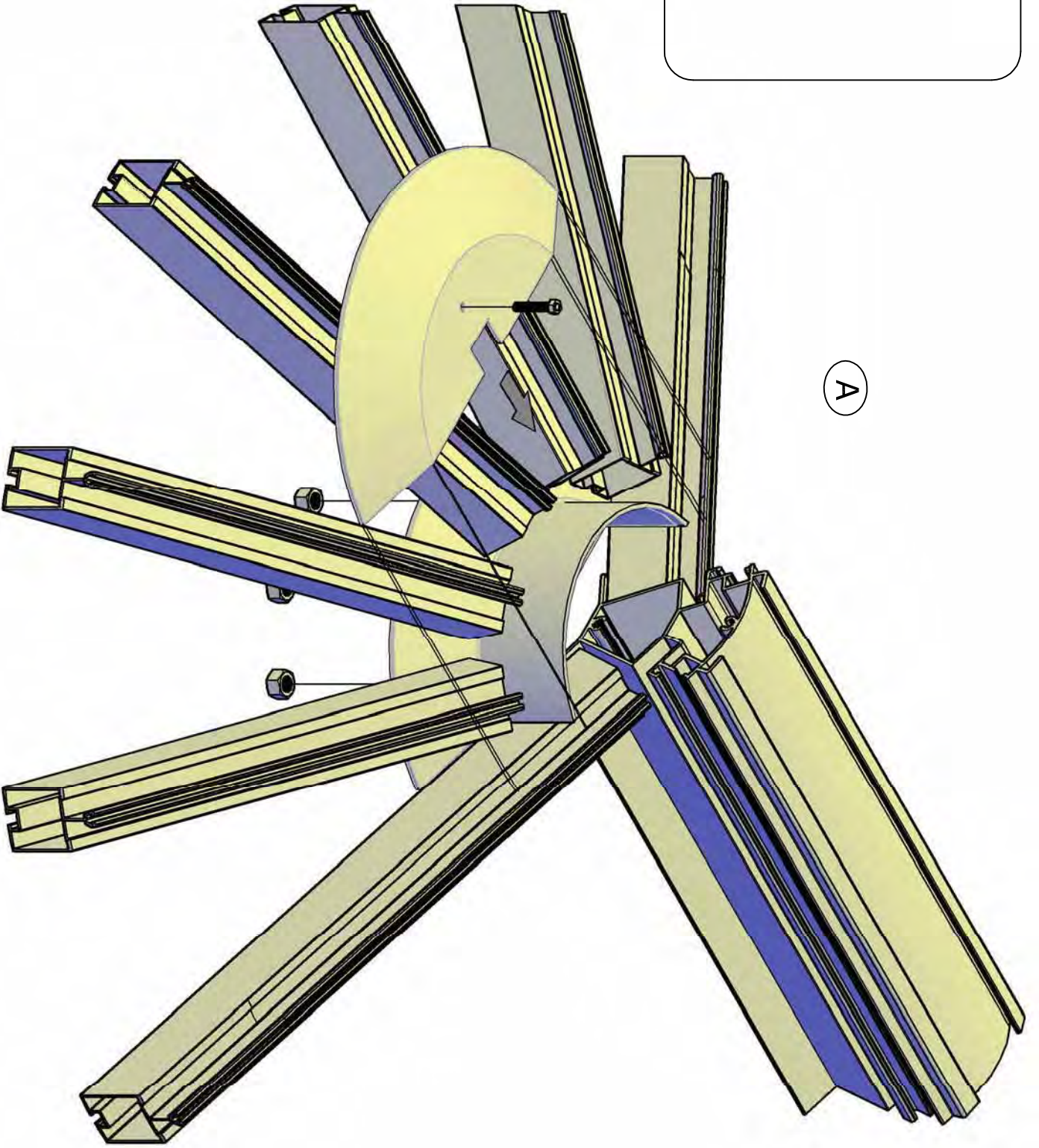
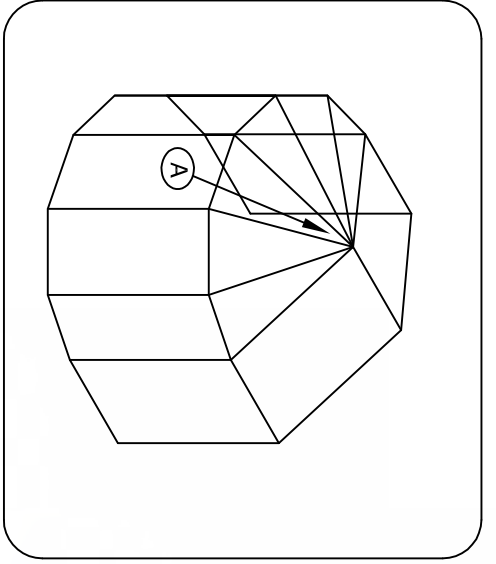

OR6

TYPE B

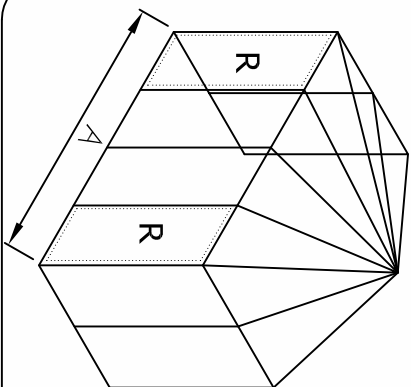

TYPE C

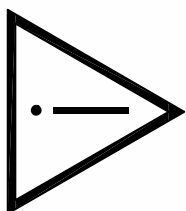
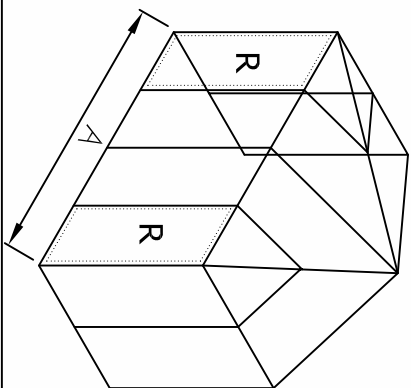

A=310
A=378

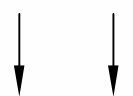

R=730 X 1850
R=698 X 1850

TYPE C + 

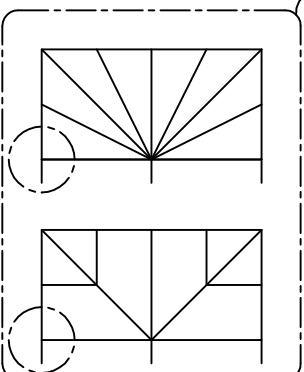
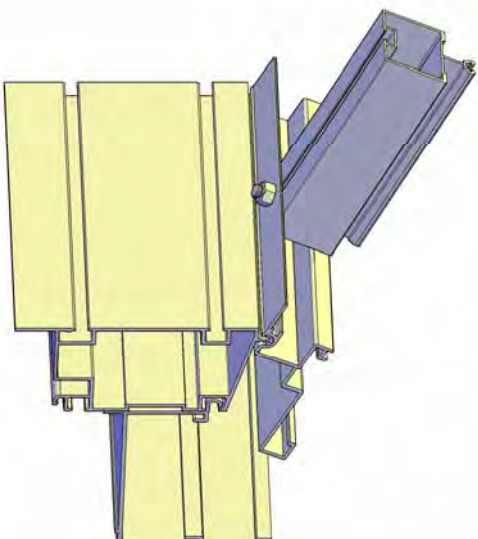
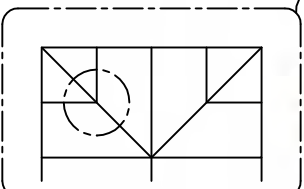
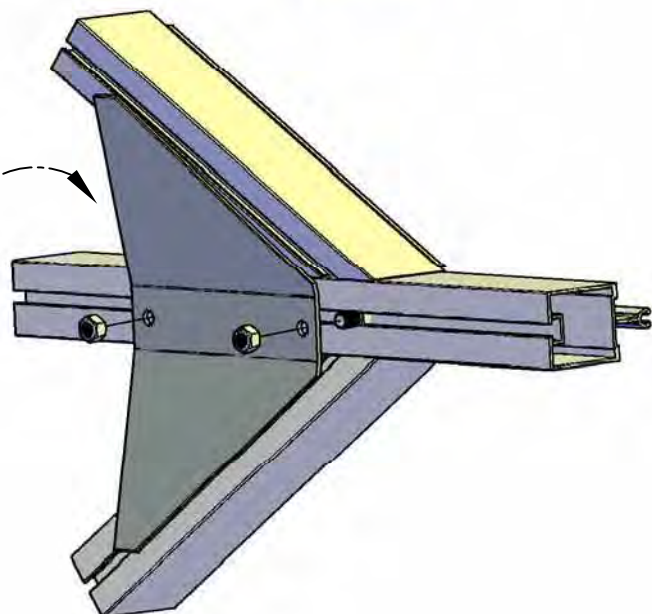
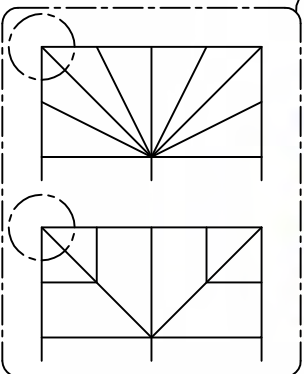
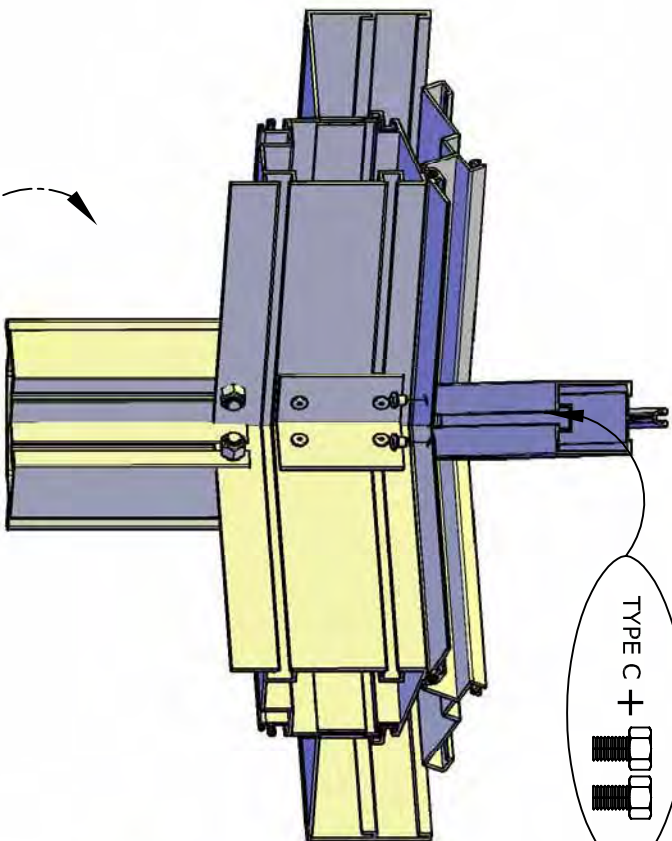

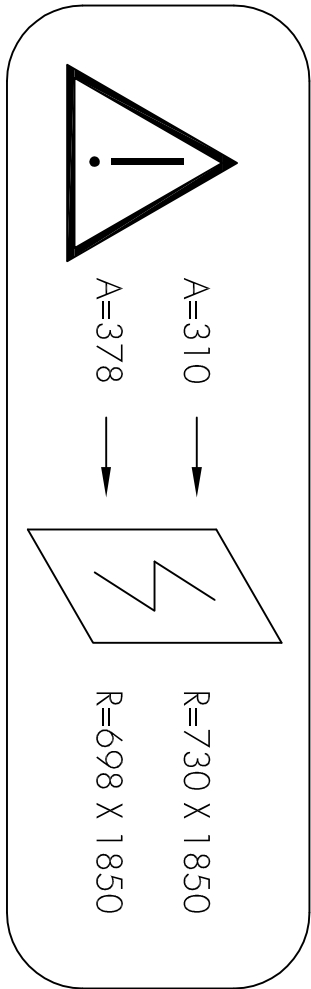
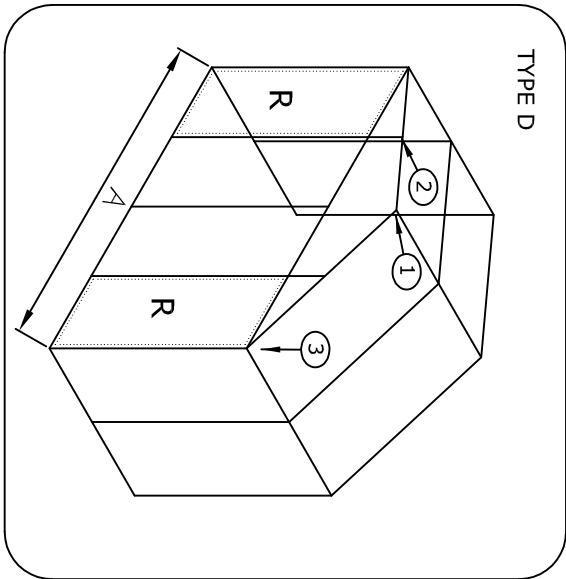

1

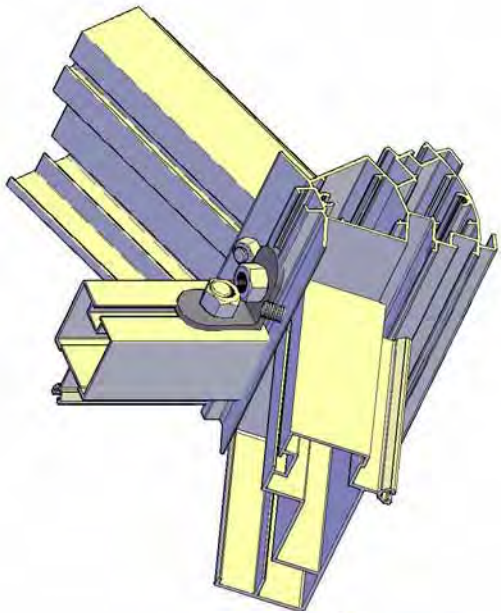

2

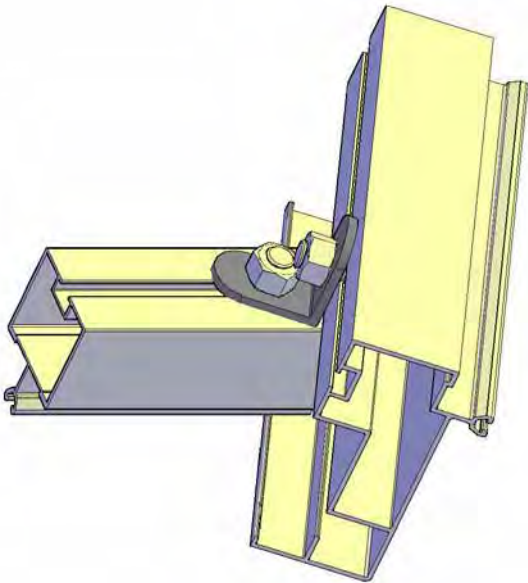

3

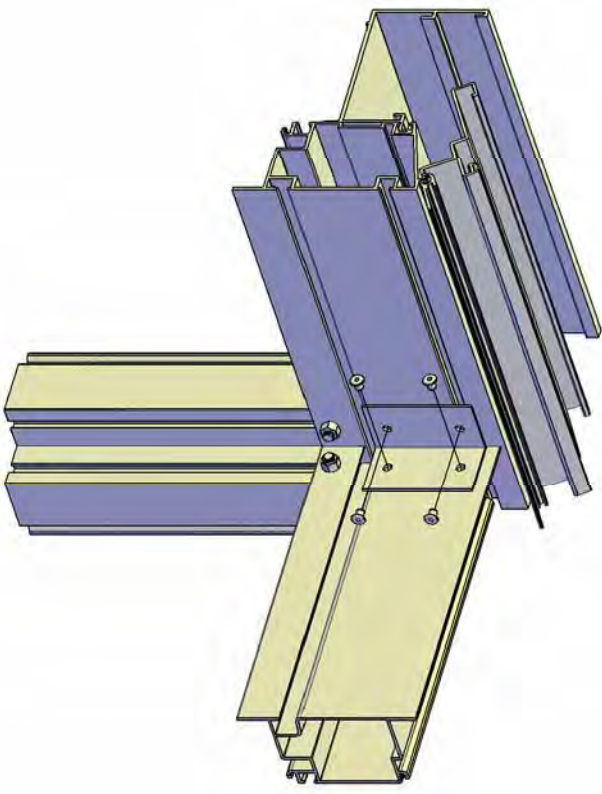

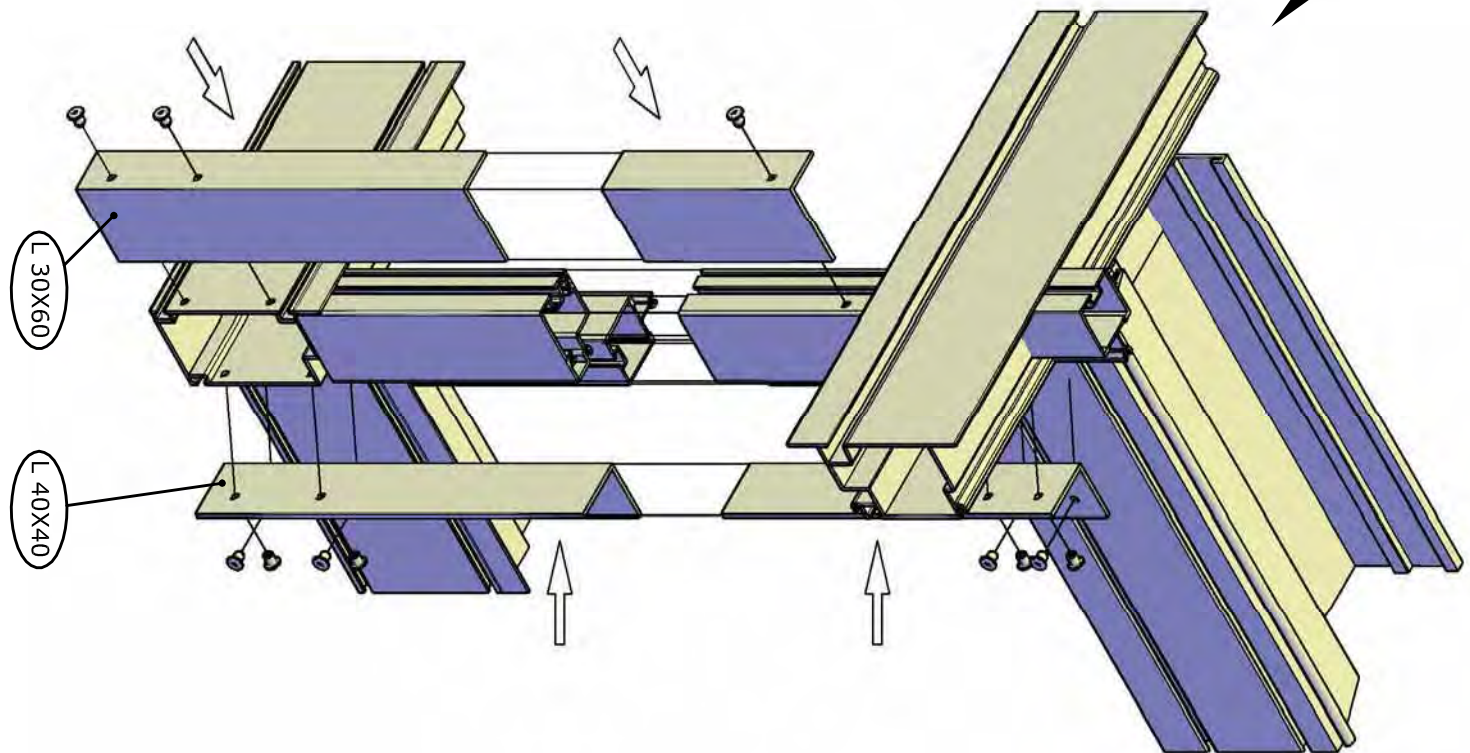
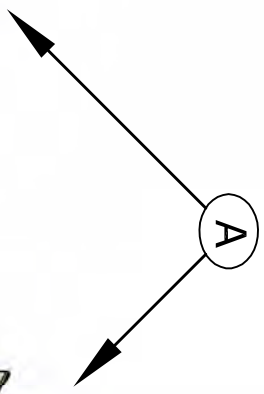
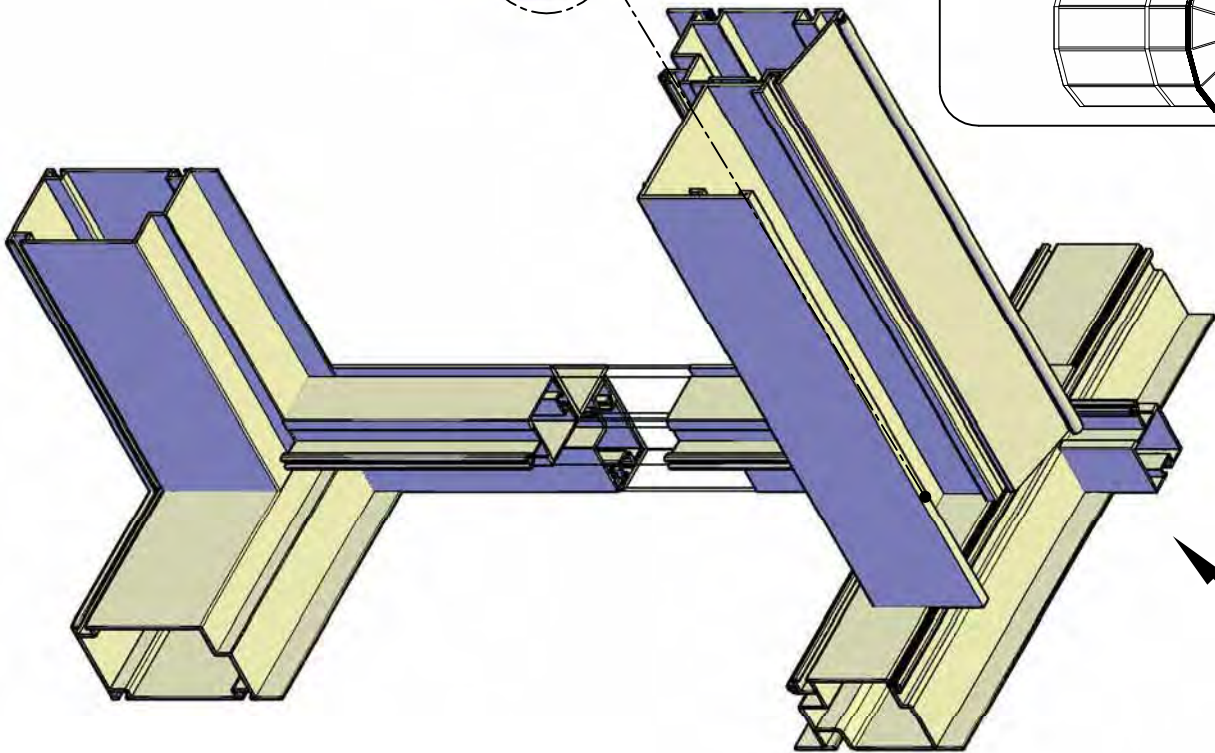
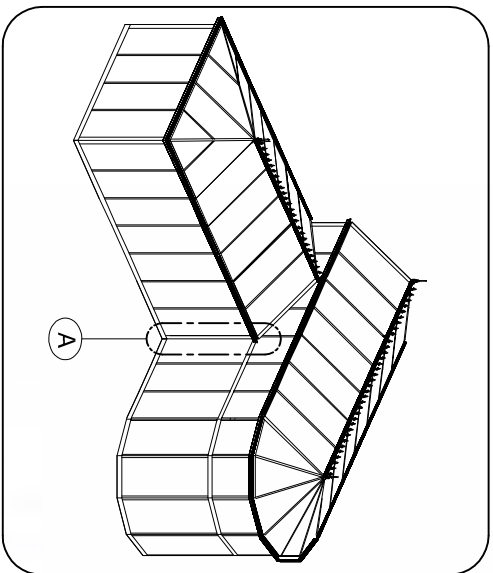
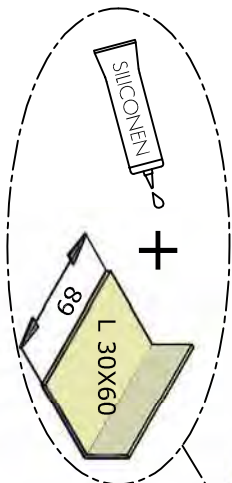

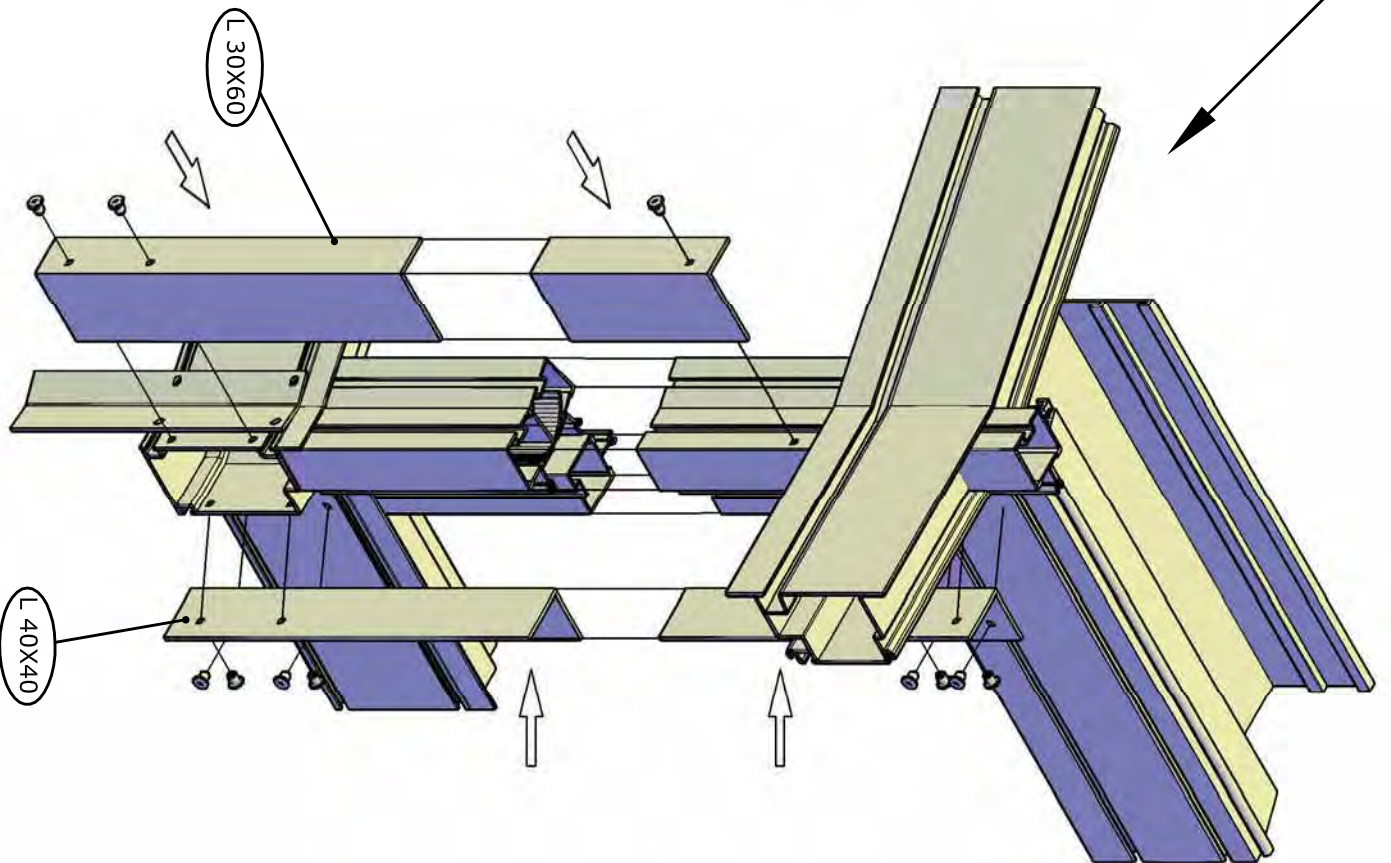
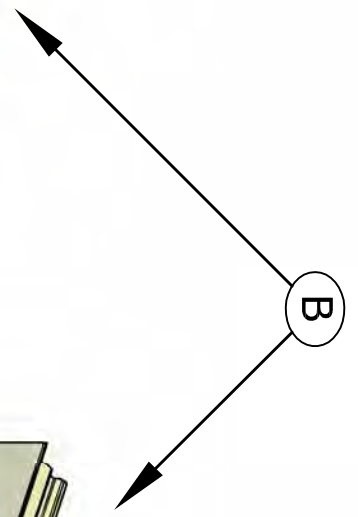
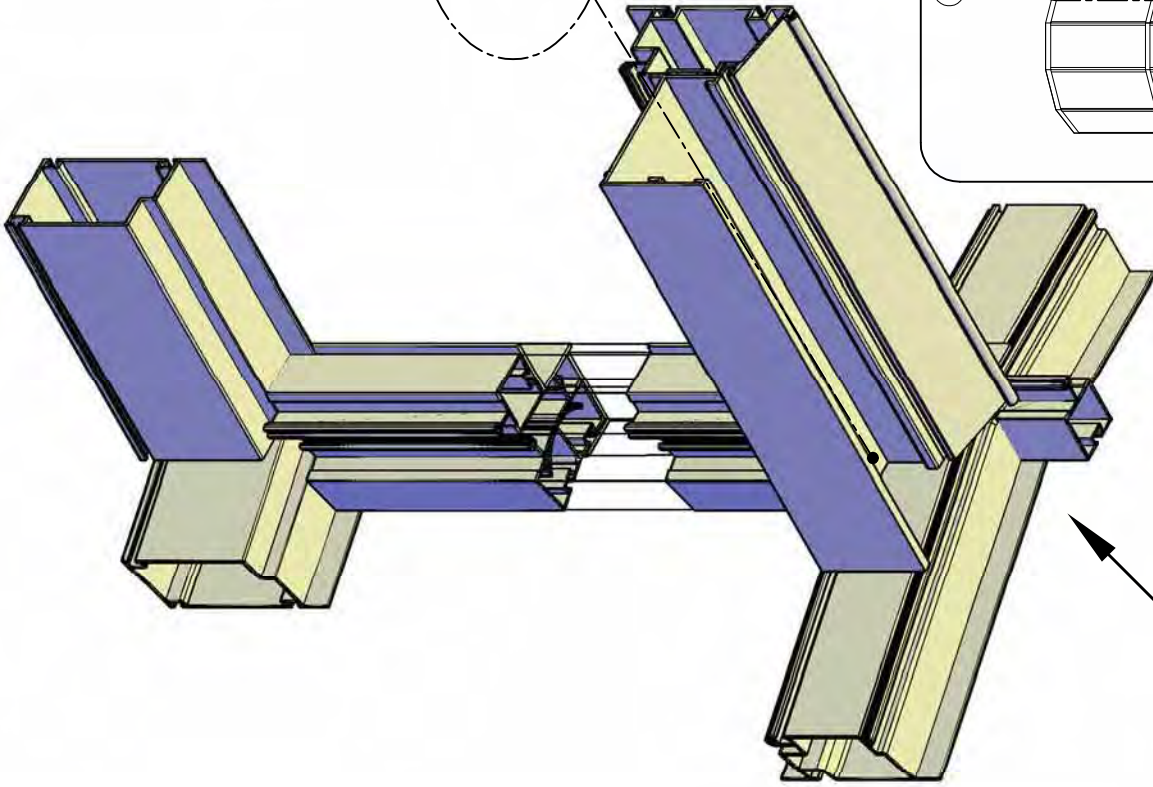
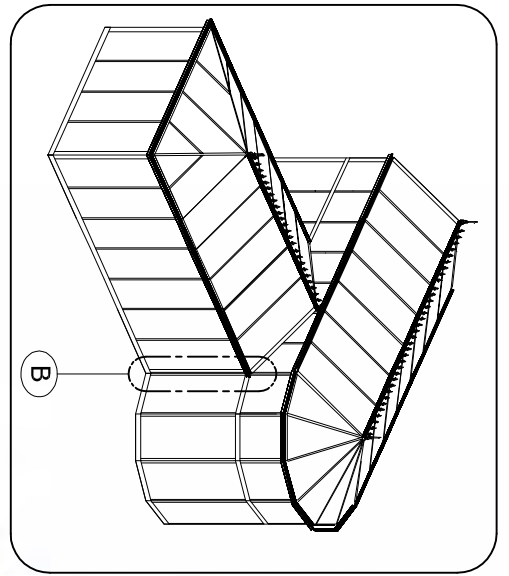
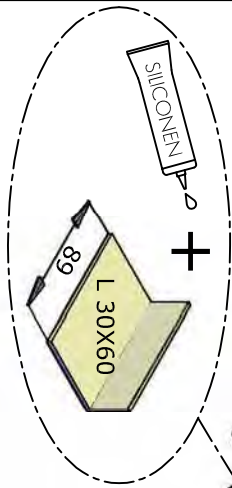

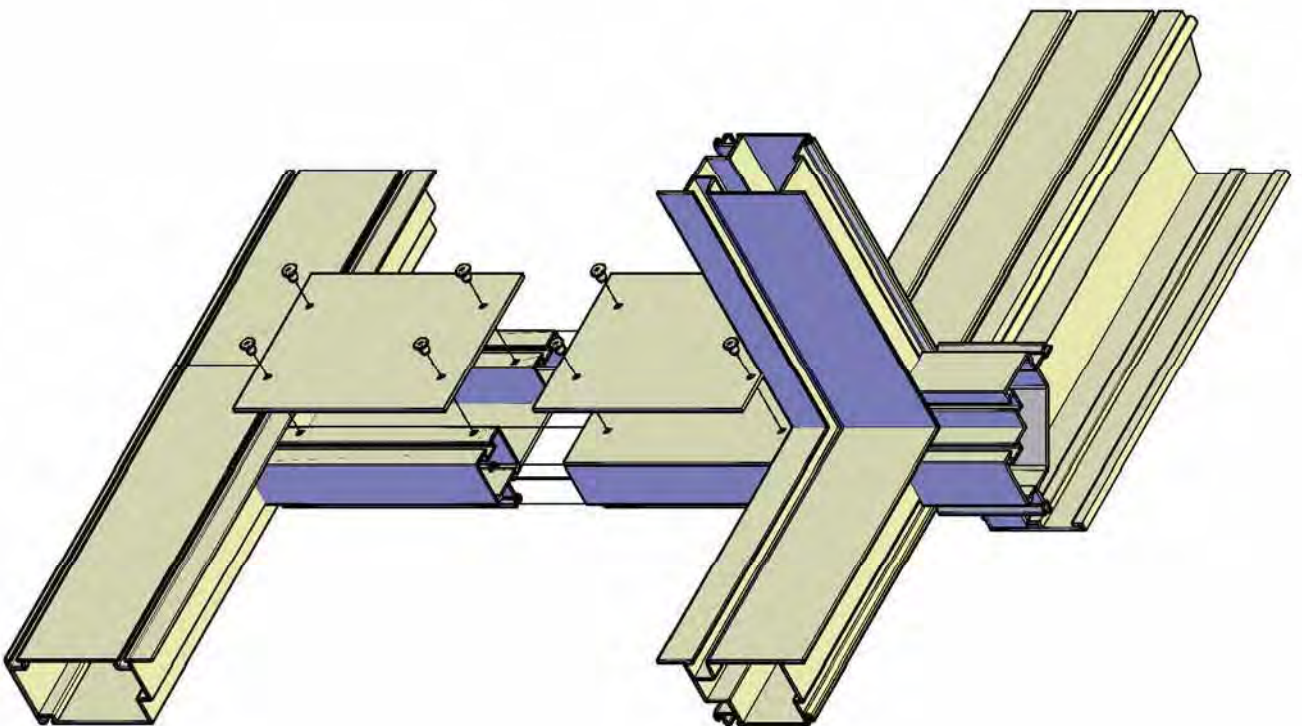
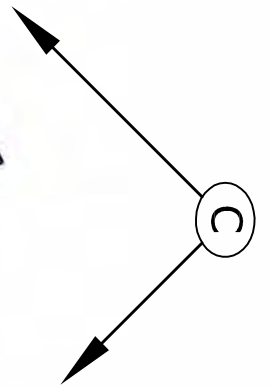
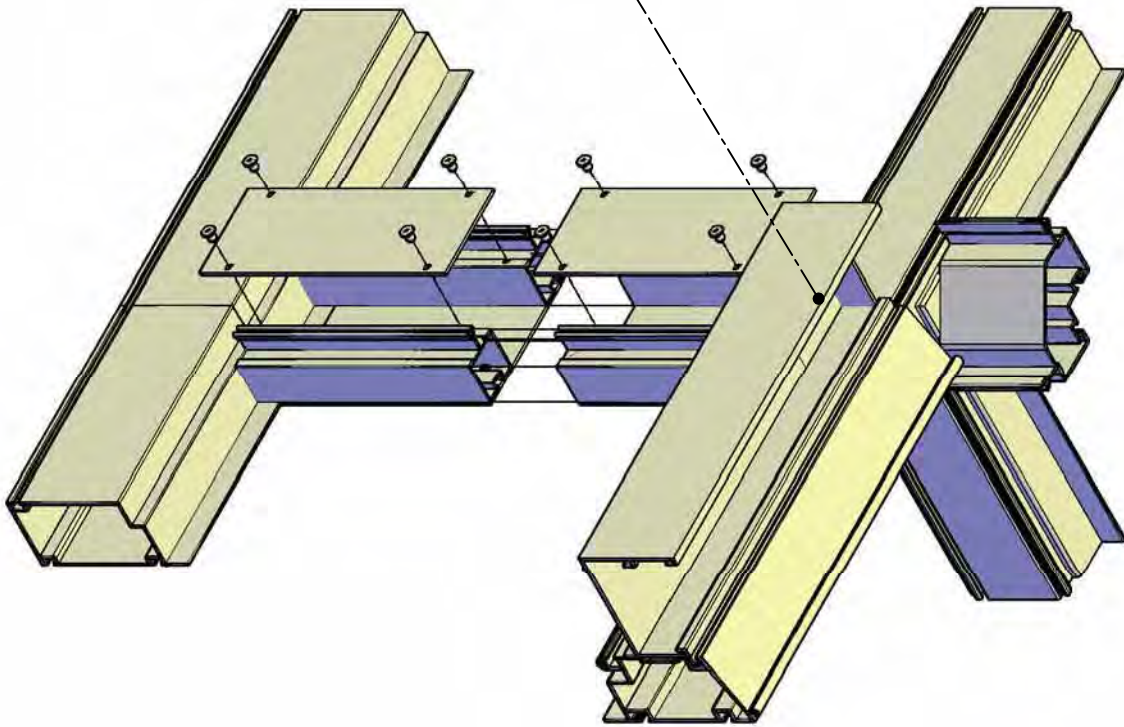
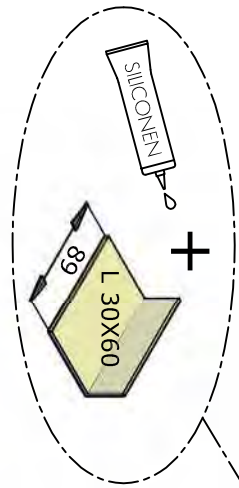
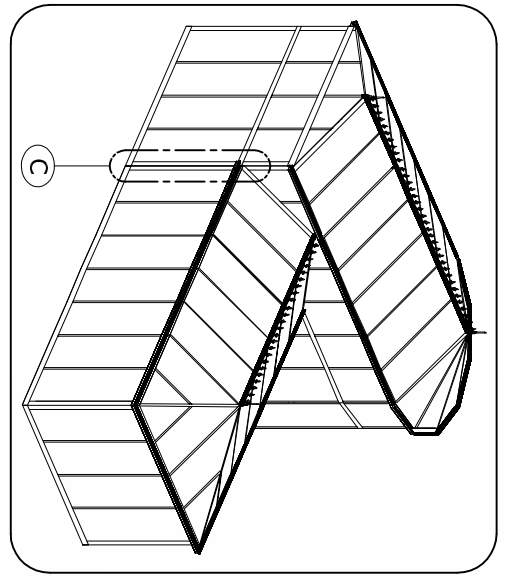

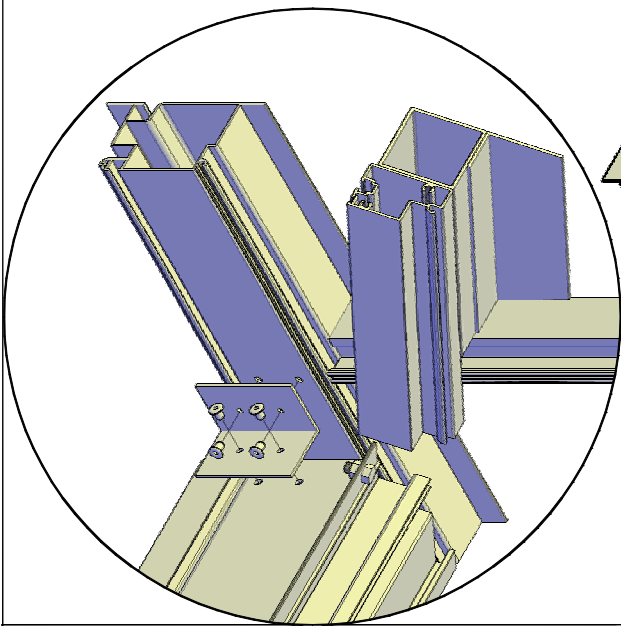
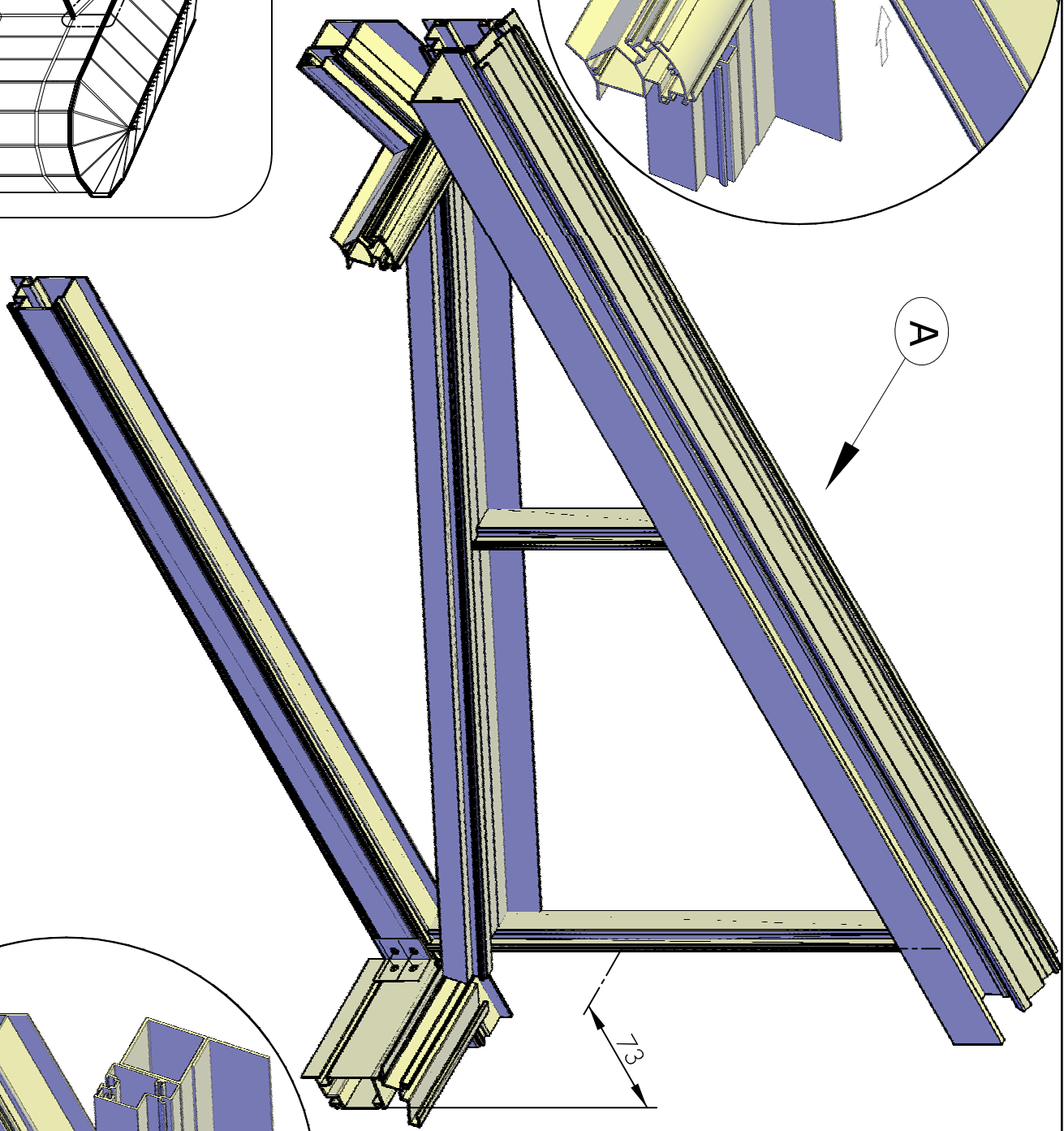
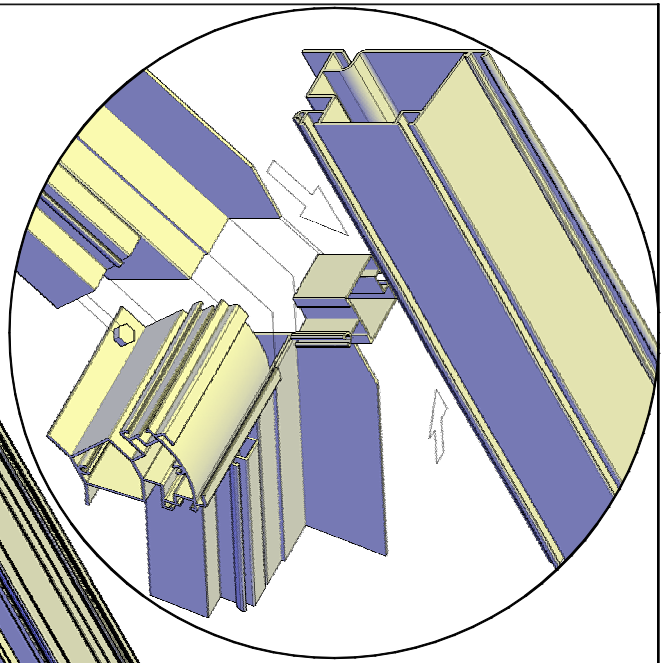
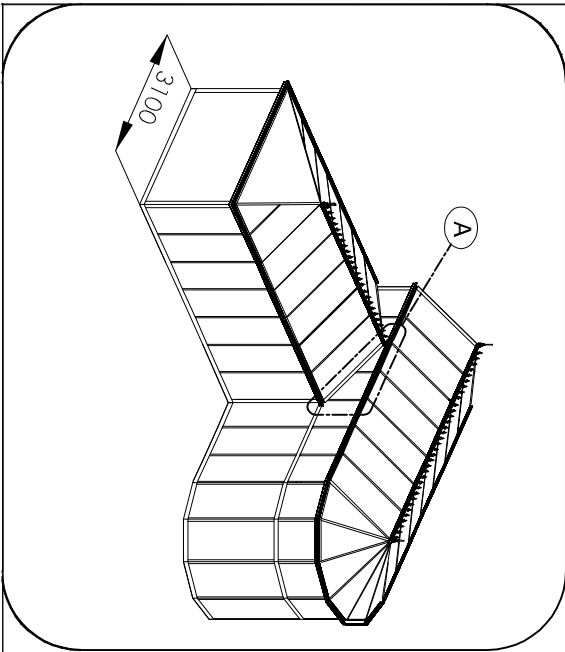

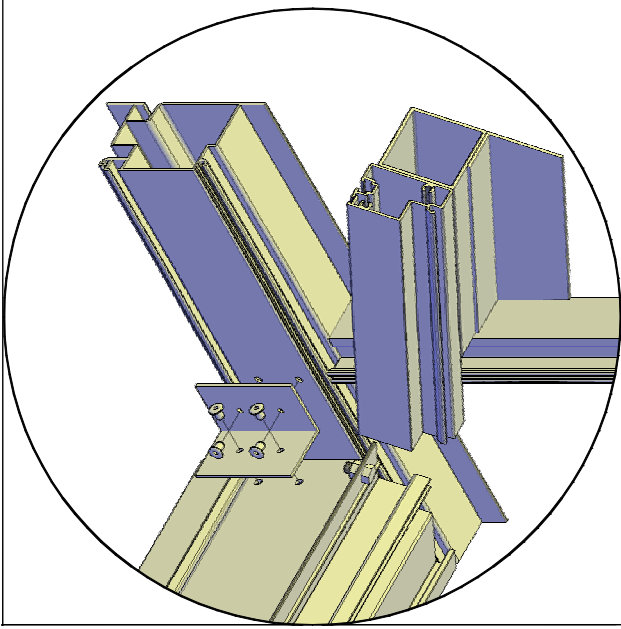
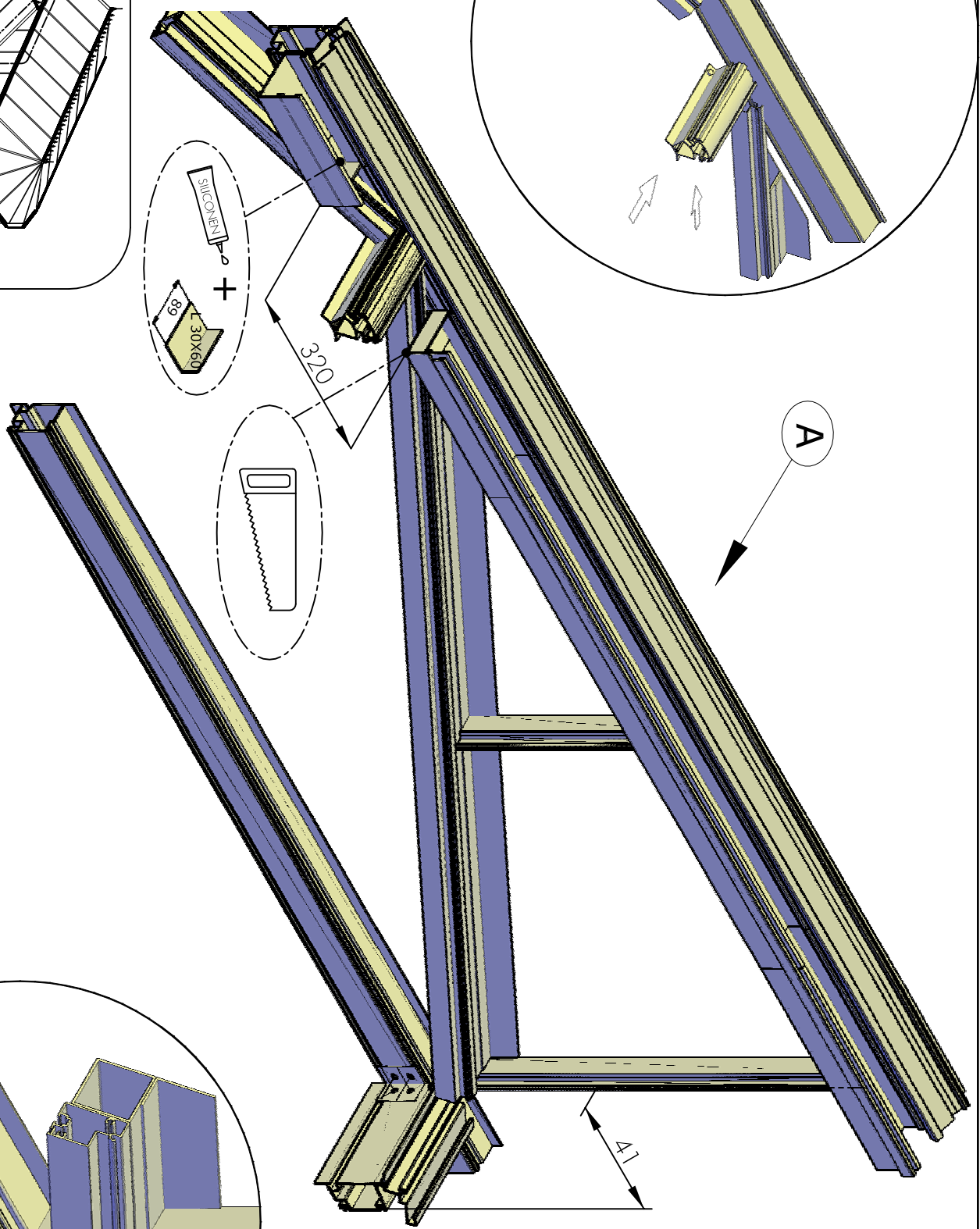
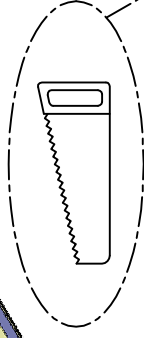
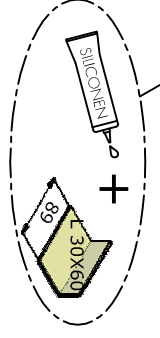
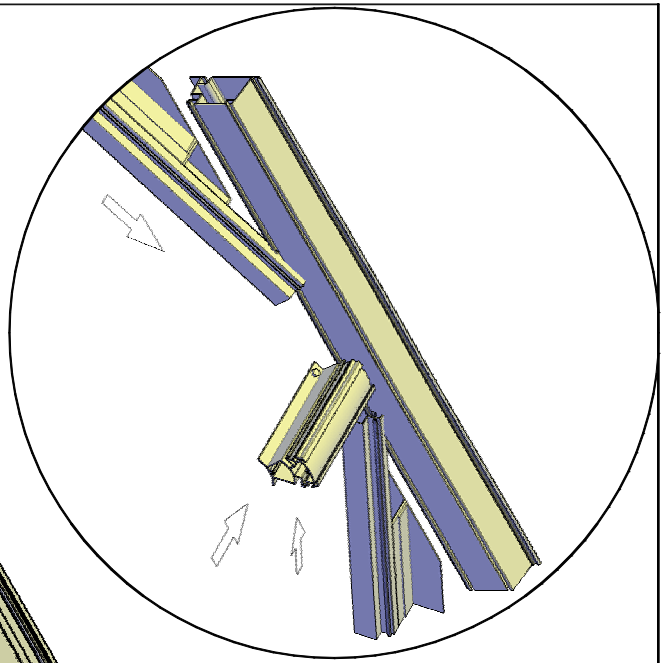
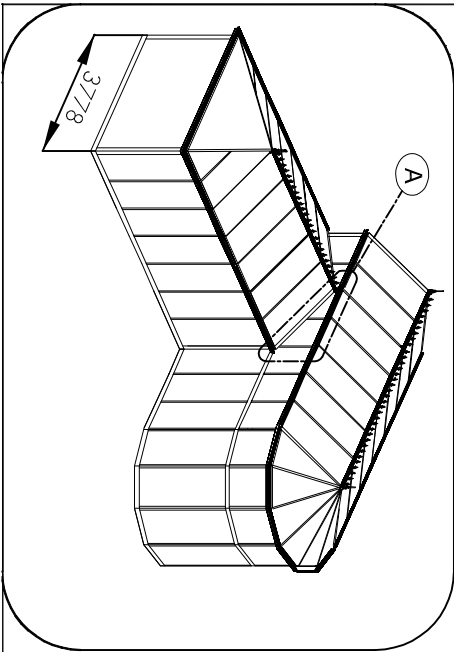

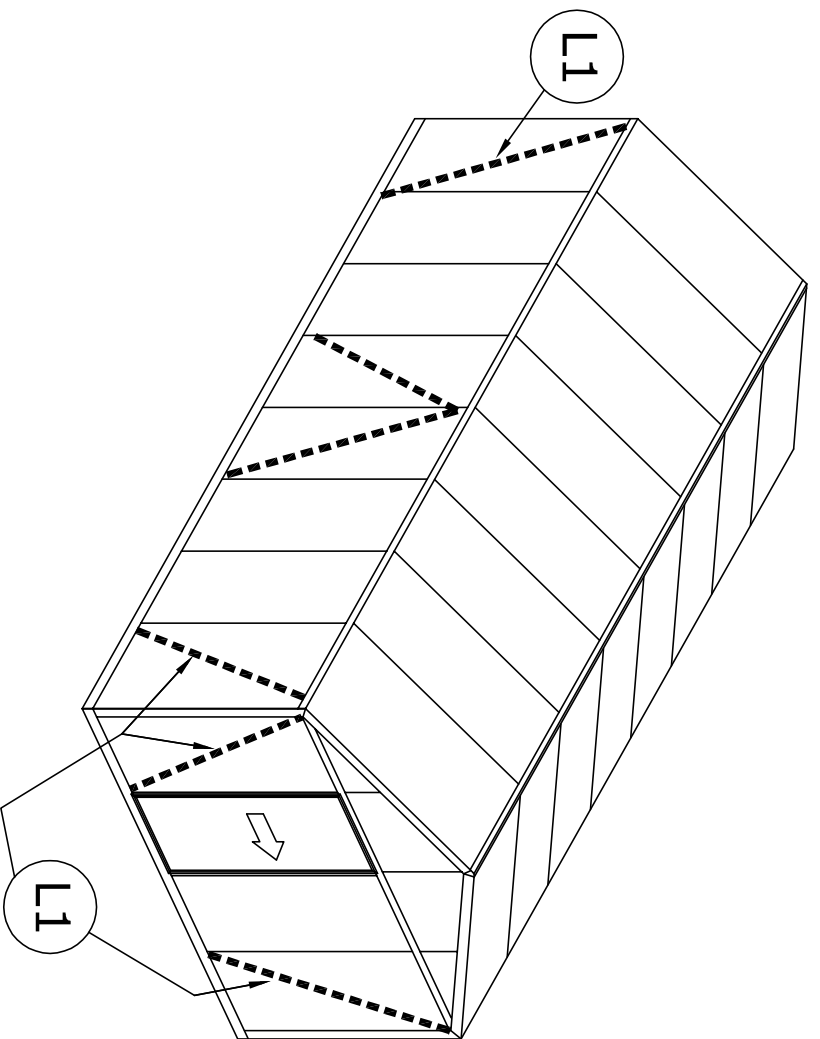

L1 = 1975mm

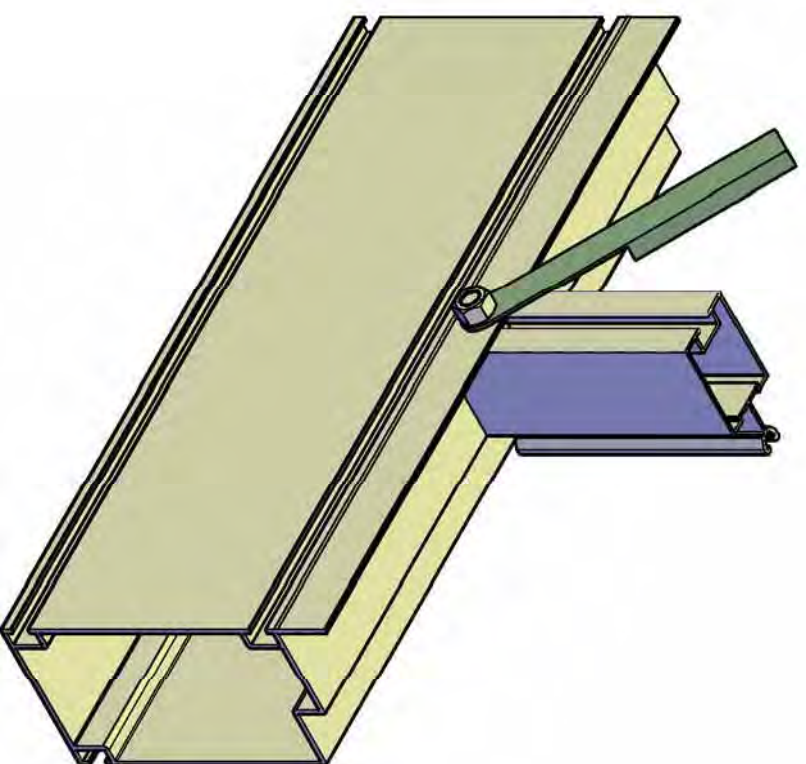

PAGODE

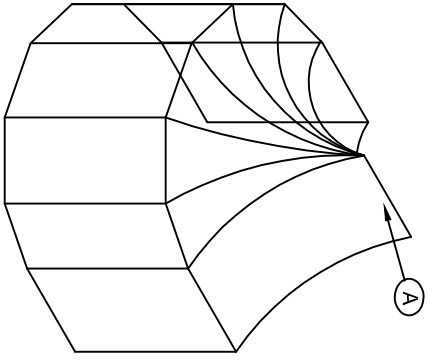

TYPE A

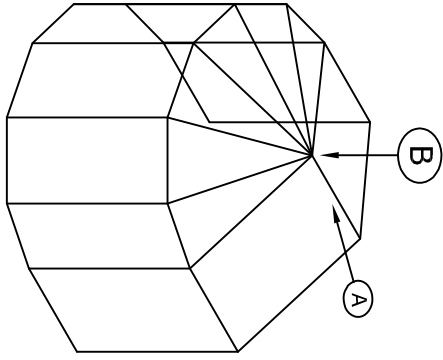

TYPE B

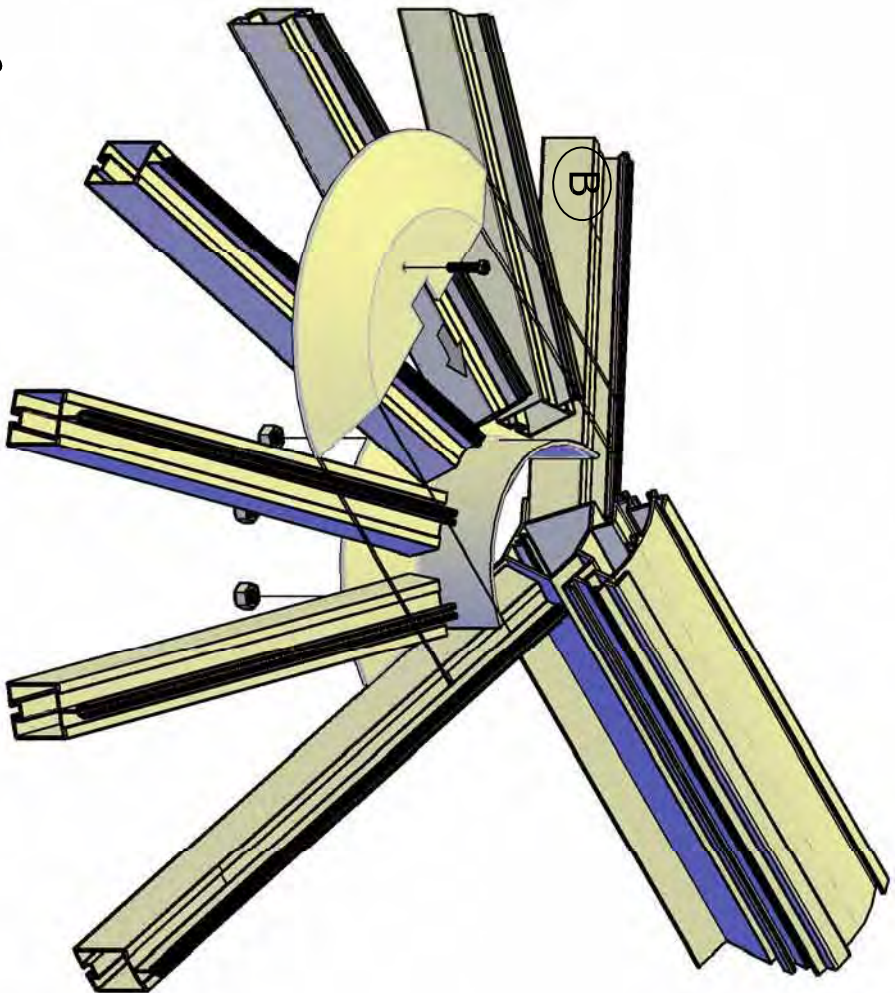
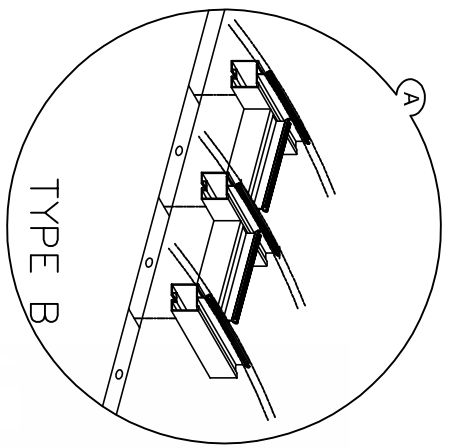
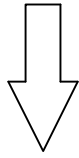
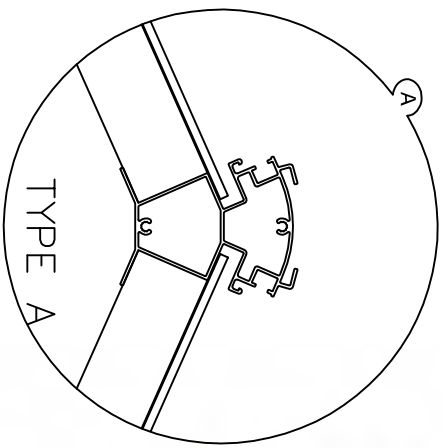
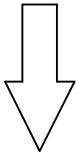
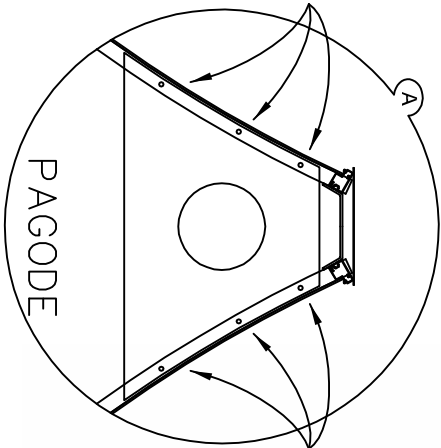
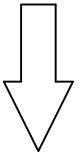
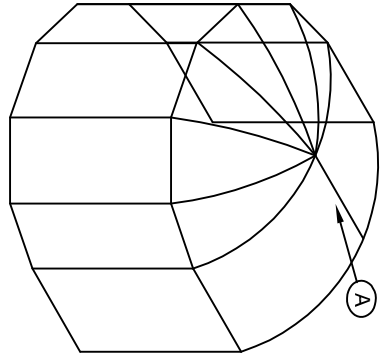

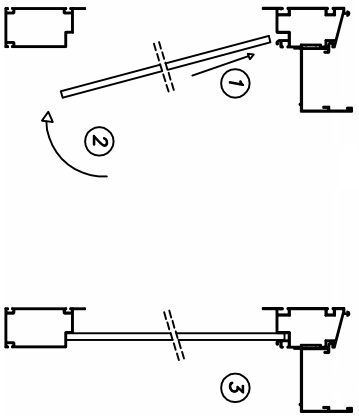
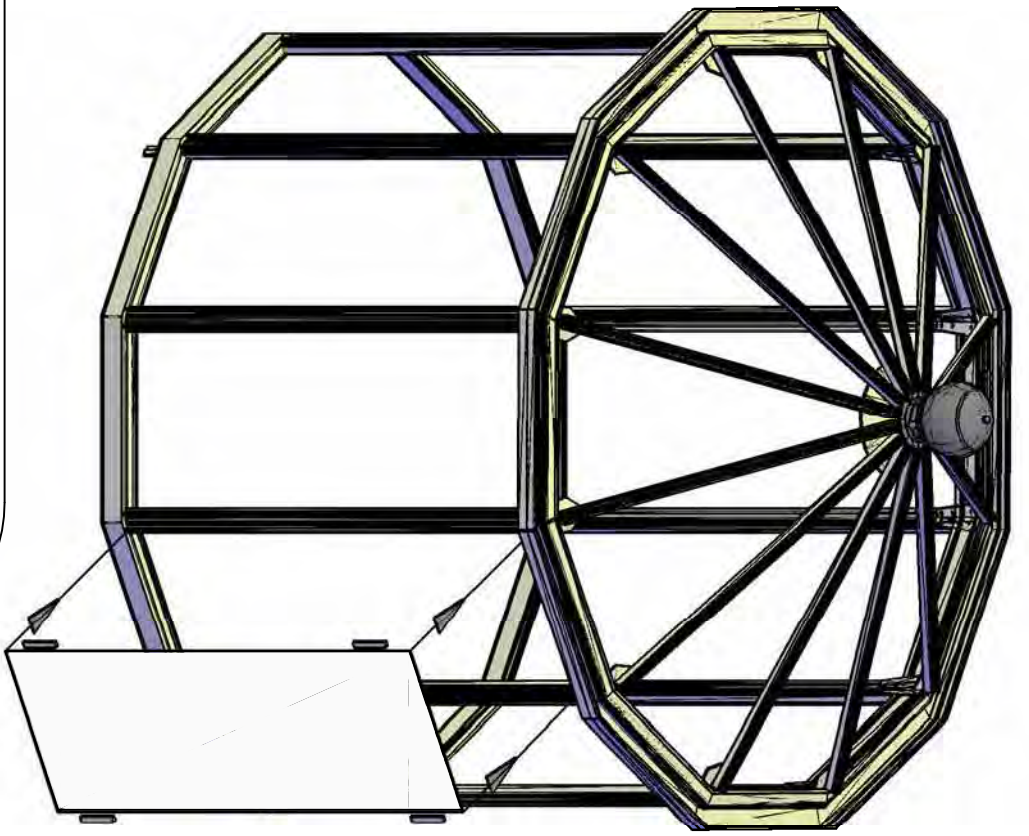

!!! K-glas: ● =Inside / Innerseite / Intérieur

SILICONEN

100 mm

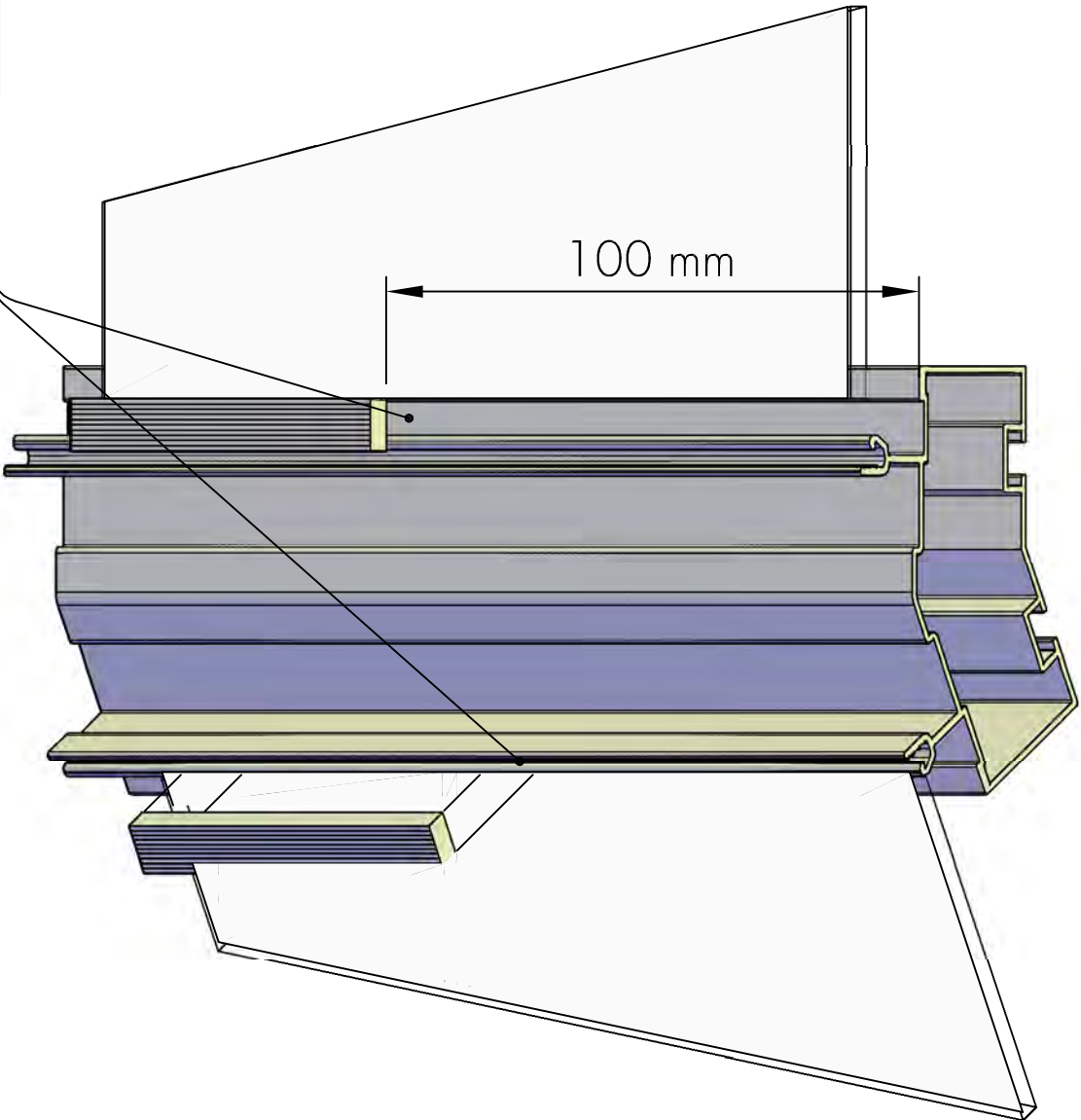

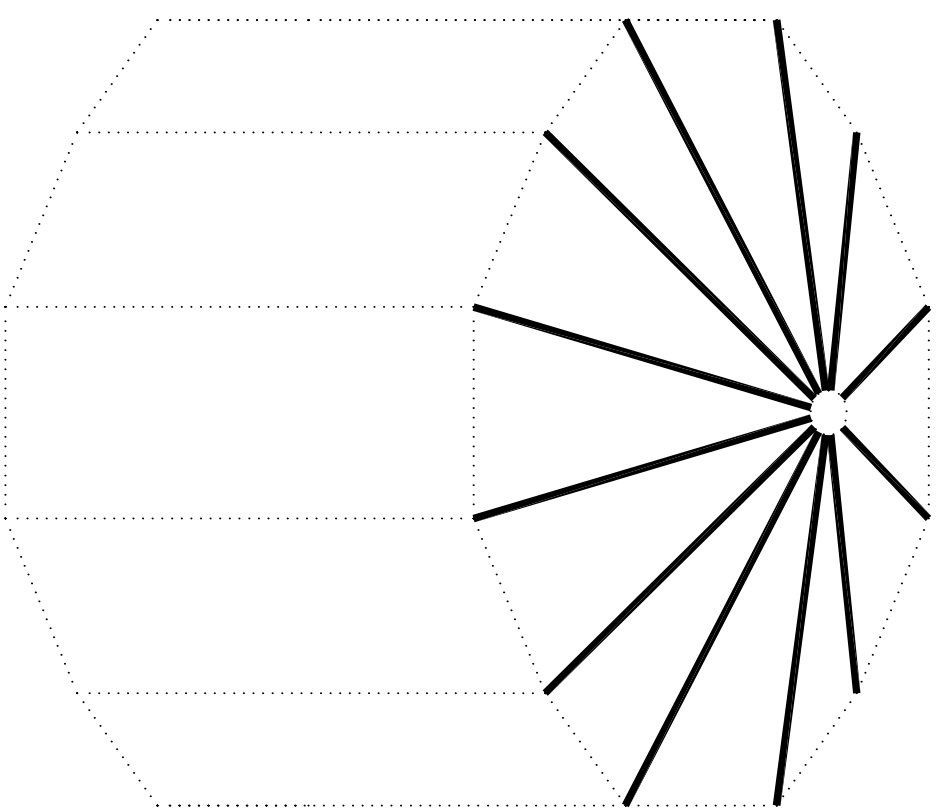
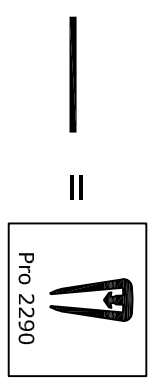
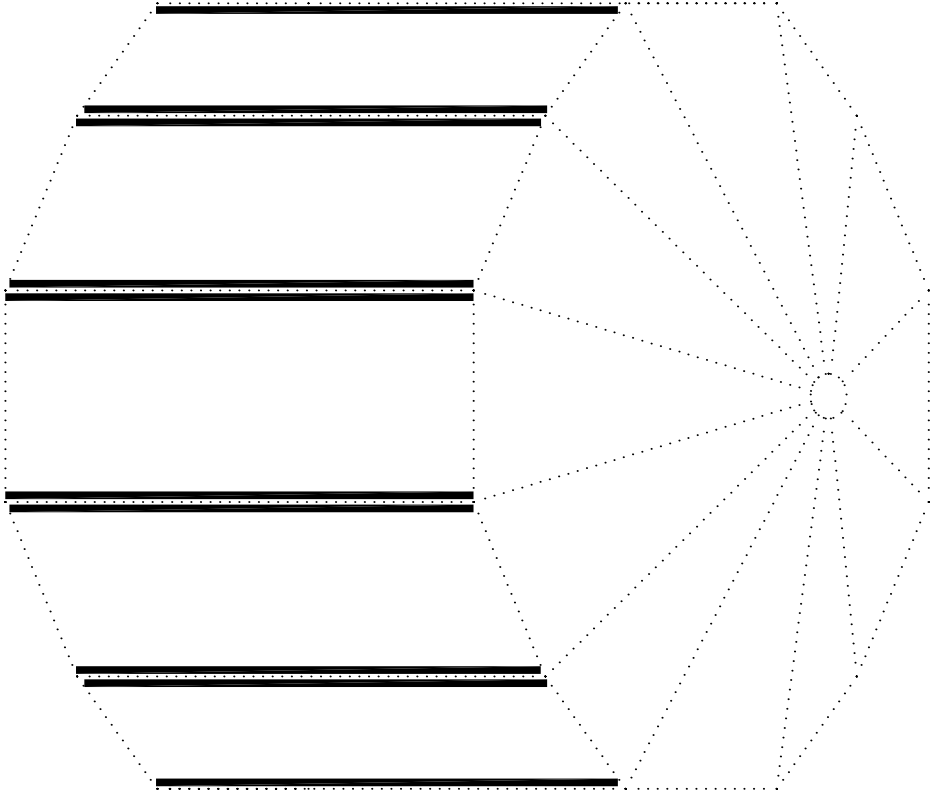
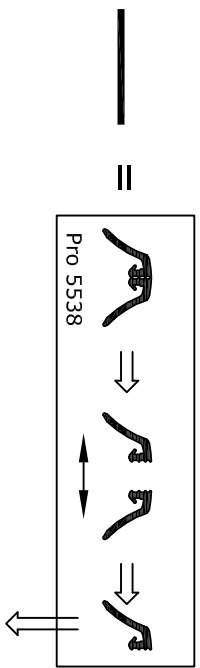

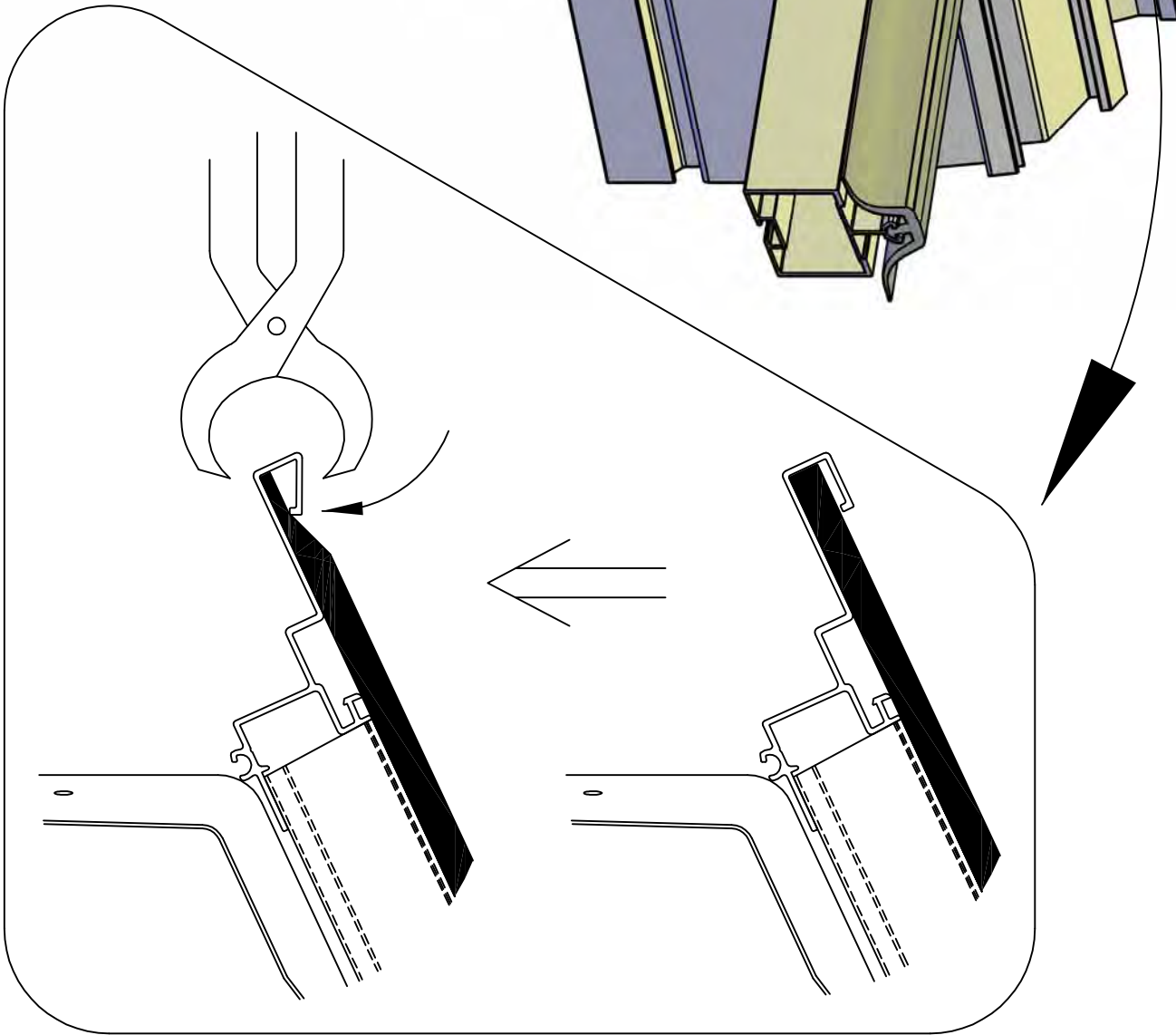
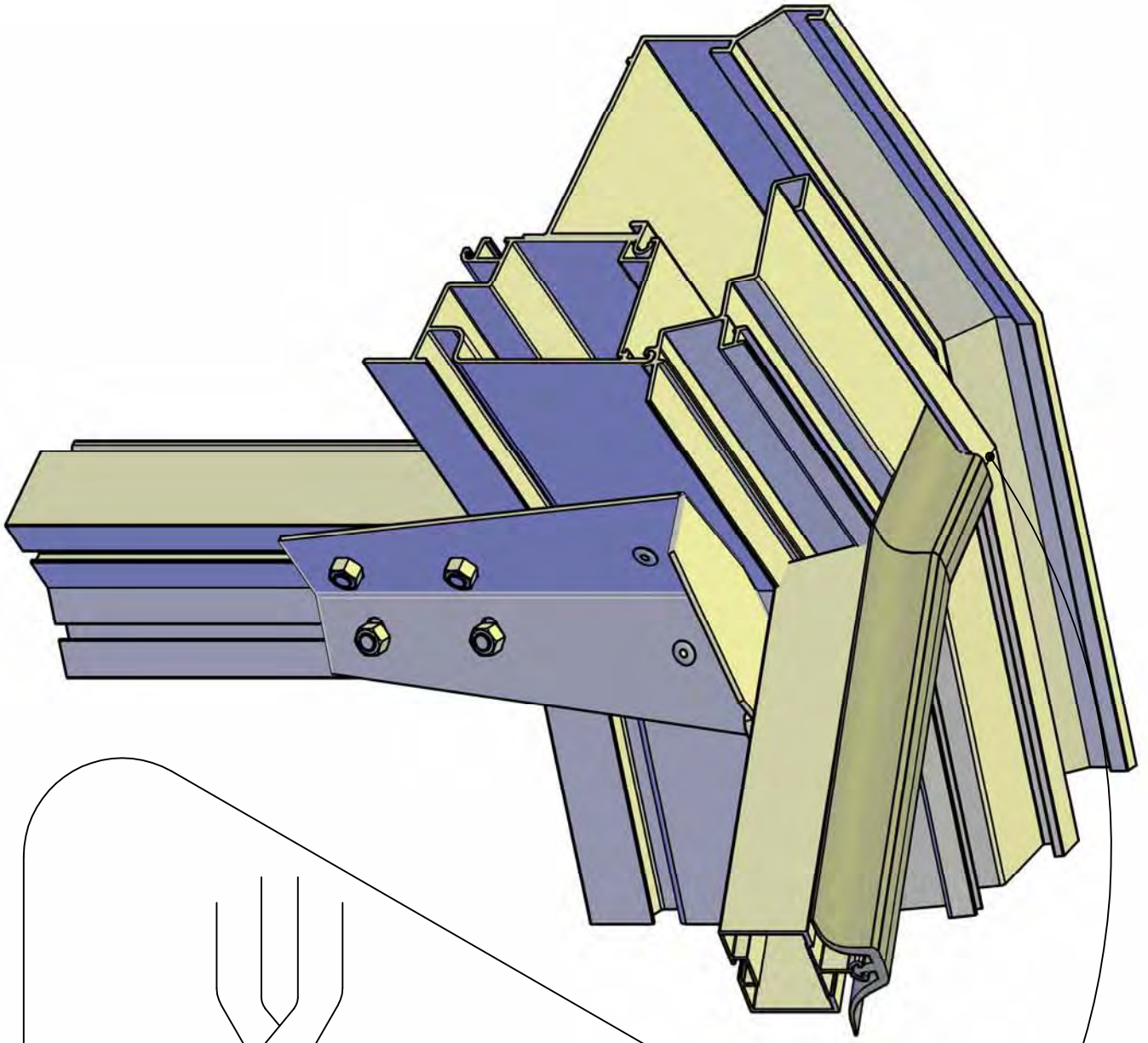

HELIOS > 6M

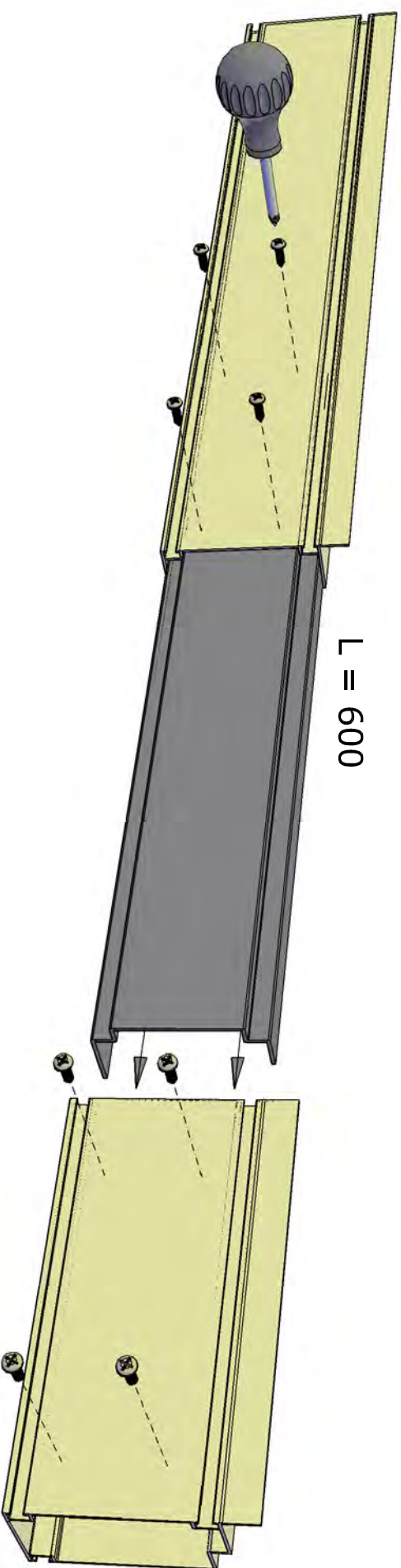
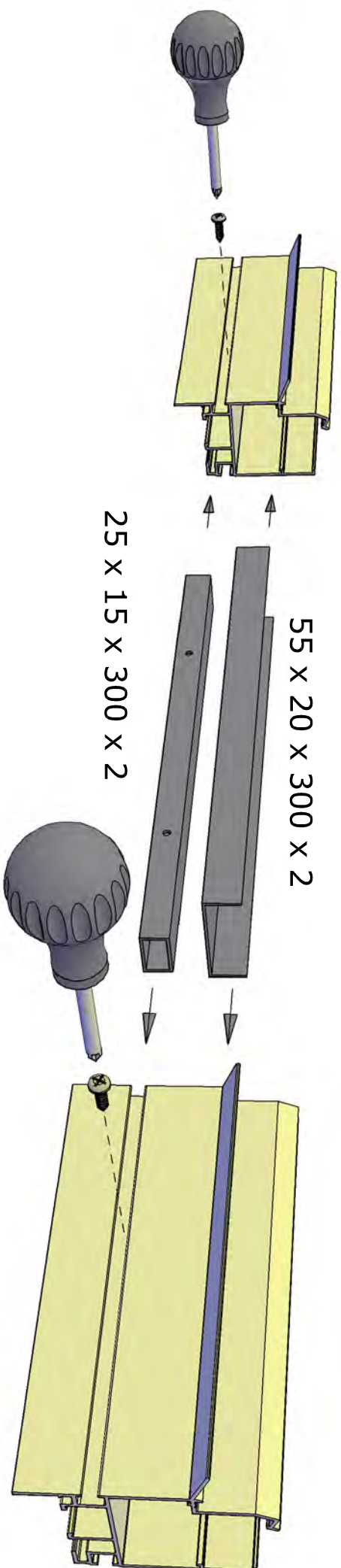
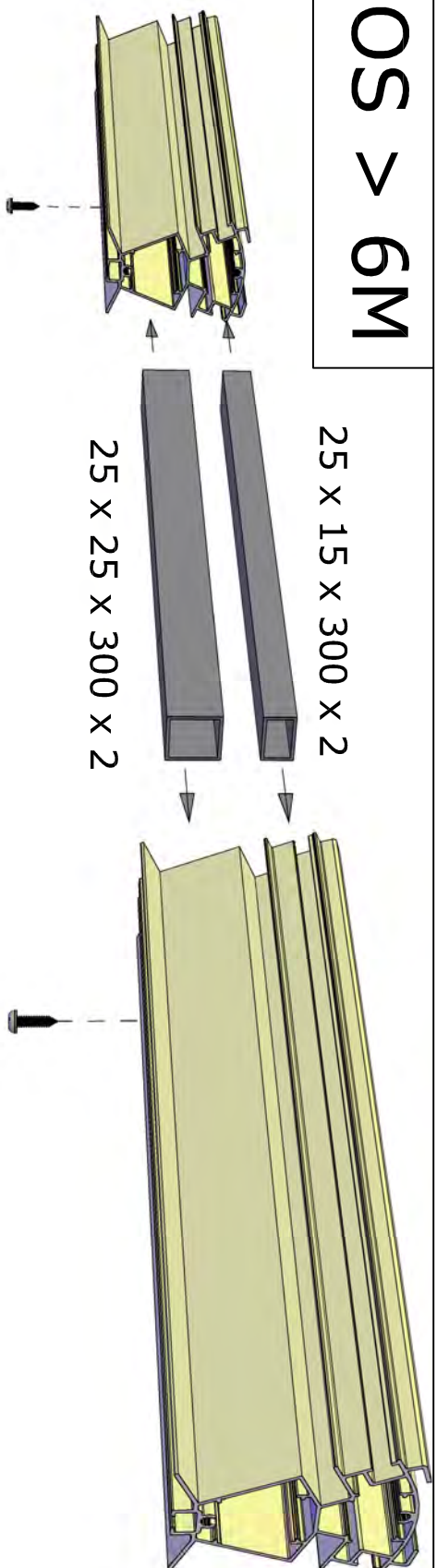

Schuifdeur-Porte Coulissante-Schiebetür-Sliding door Skydedør-Skyvedør-Skuggväv-Porta scorrevole-Skjutdörr

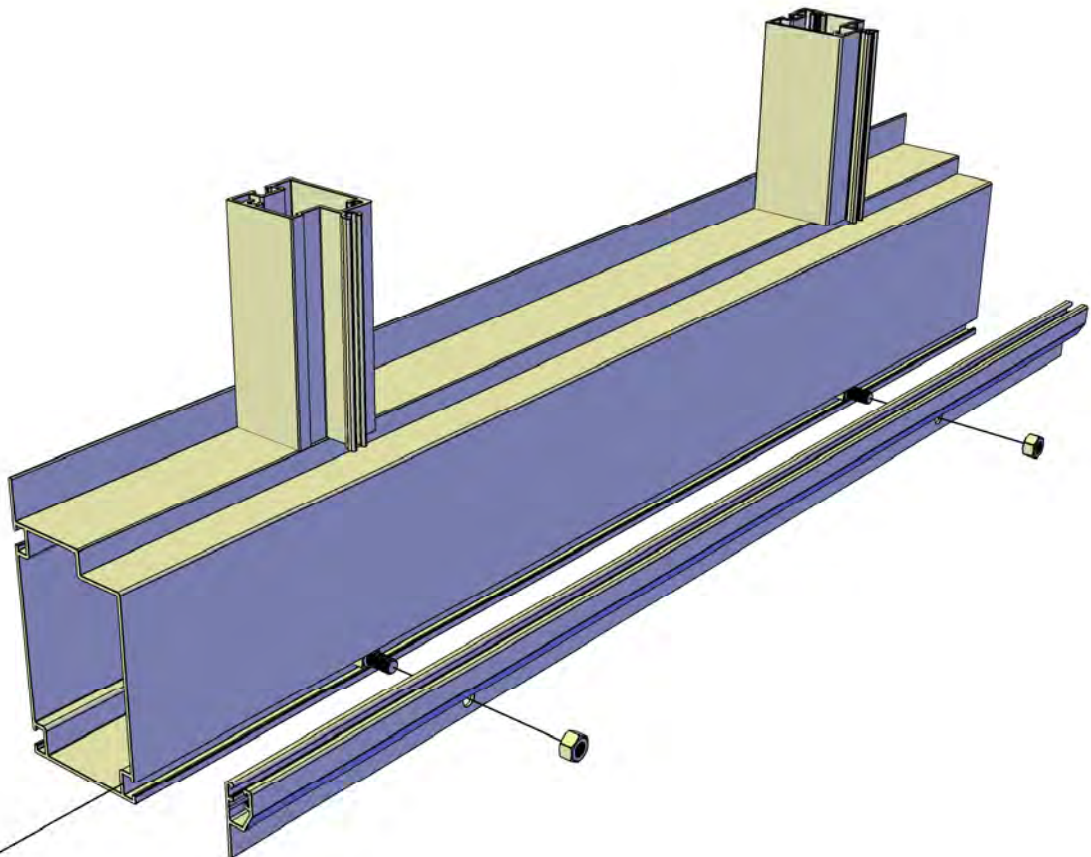
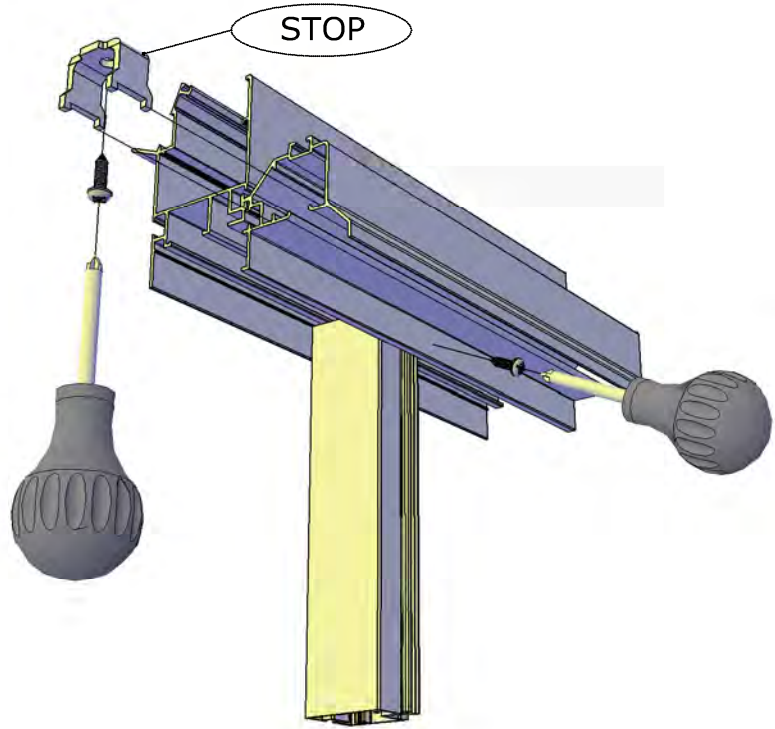
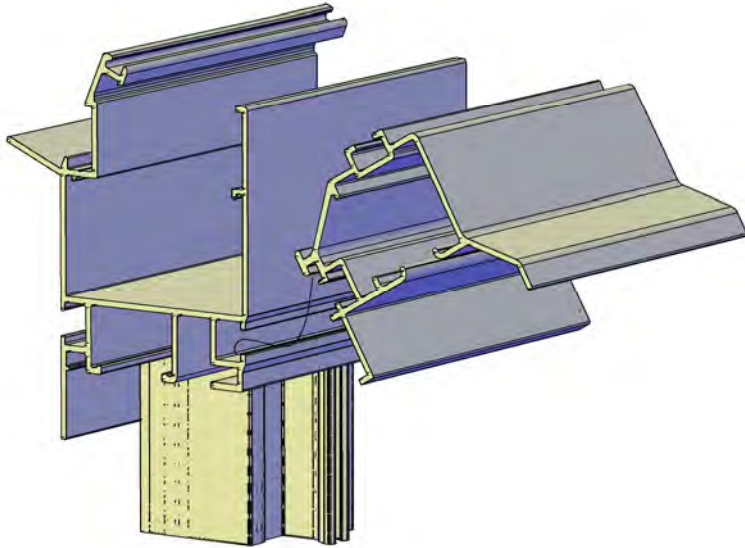
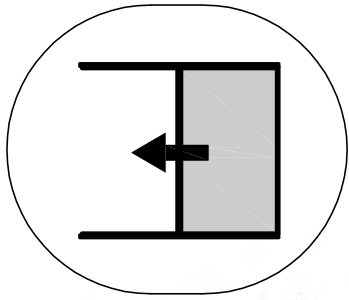

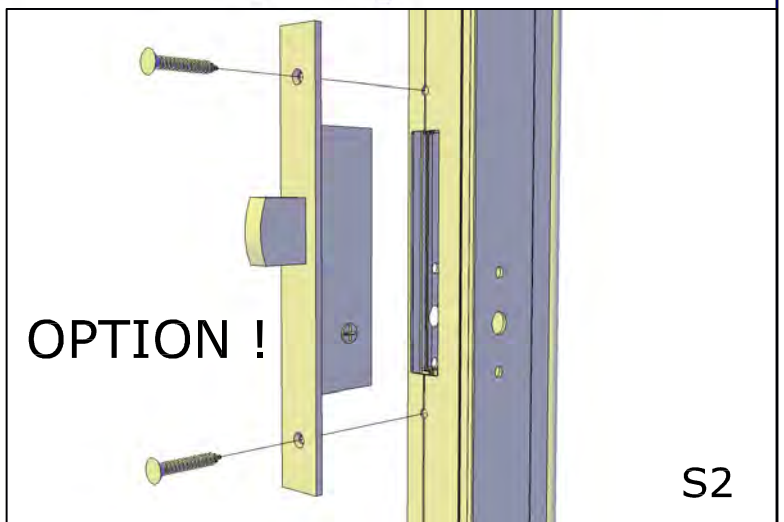
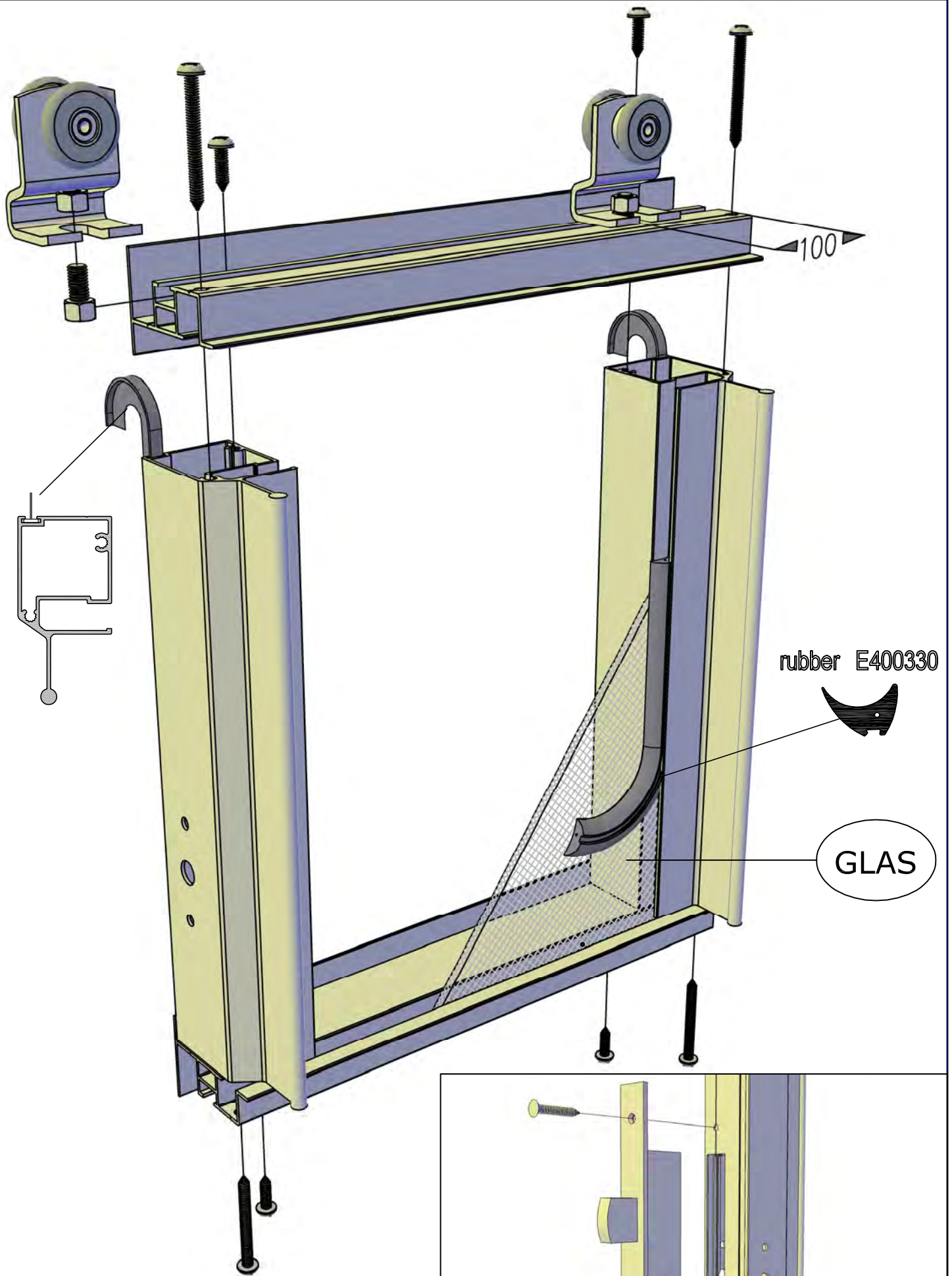

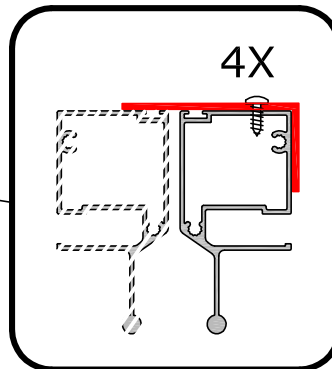
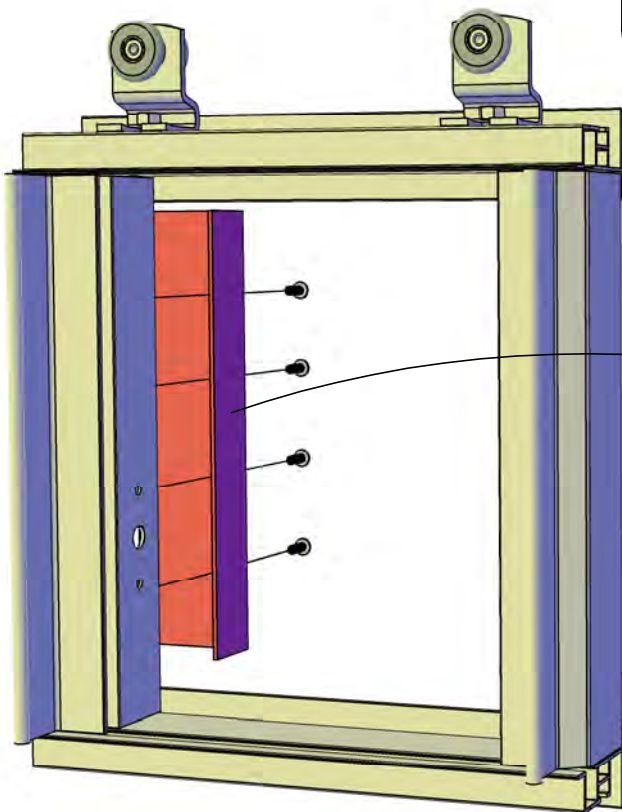
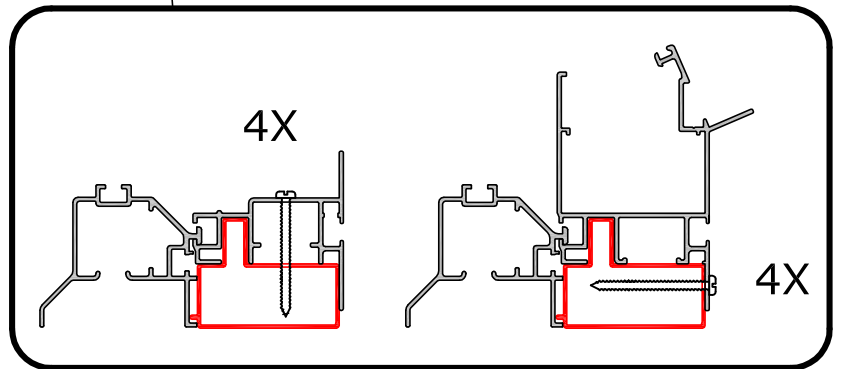
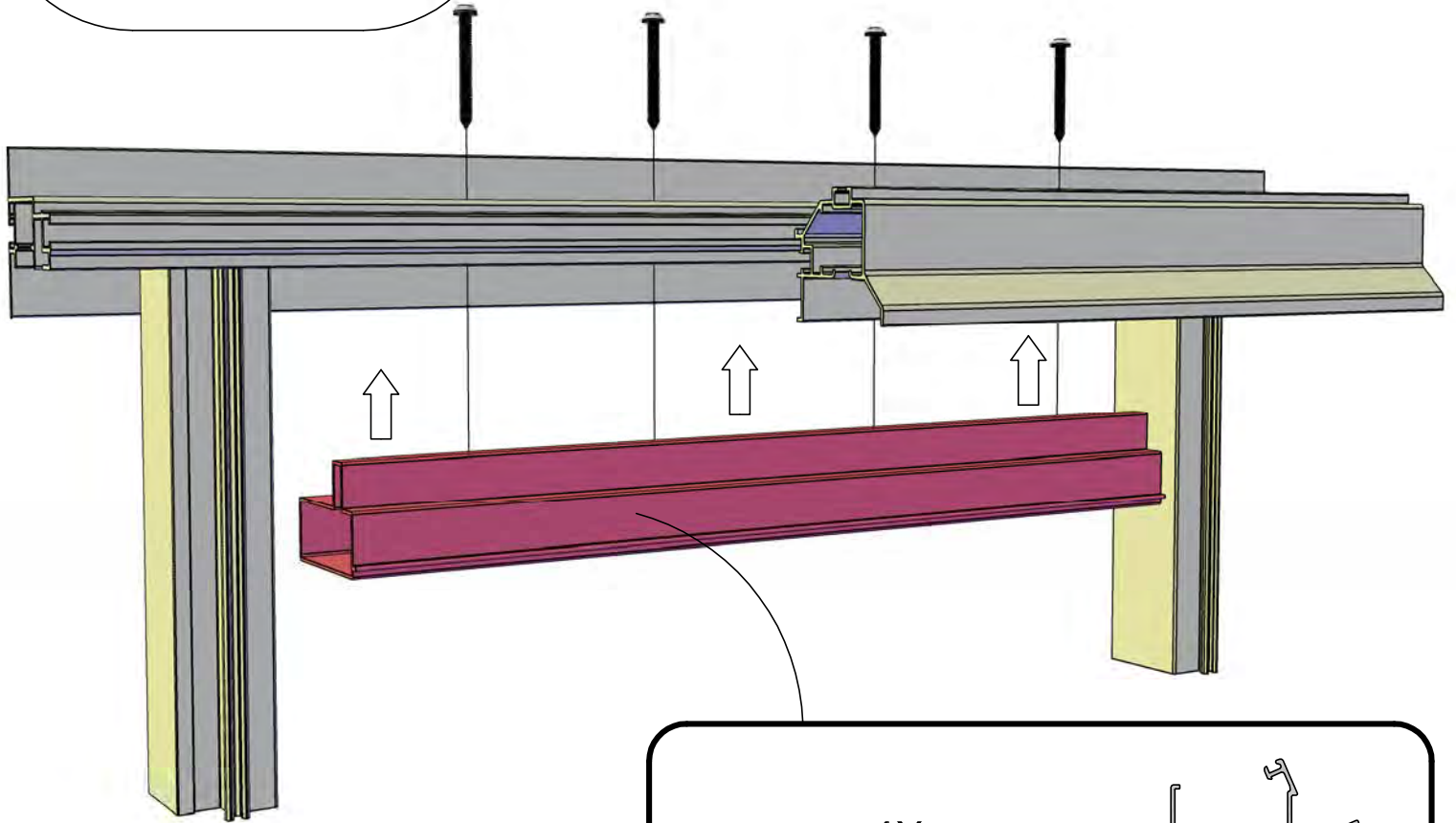
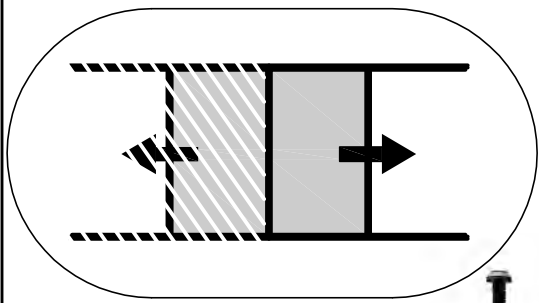

Lammelenraam - Lamellenfenster - Louvre vent
Lamellfenster - Louvre

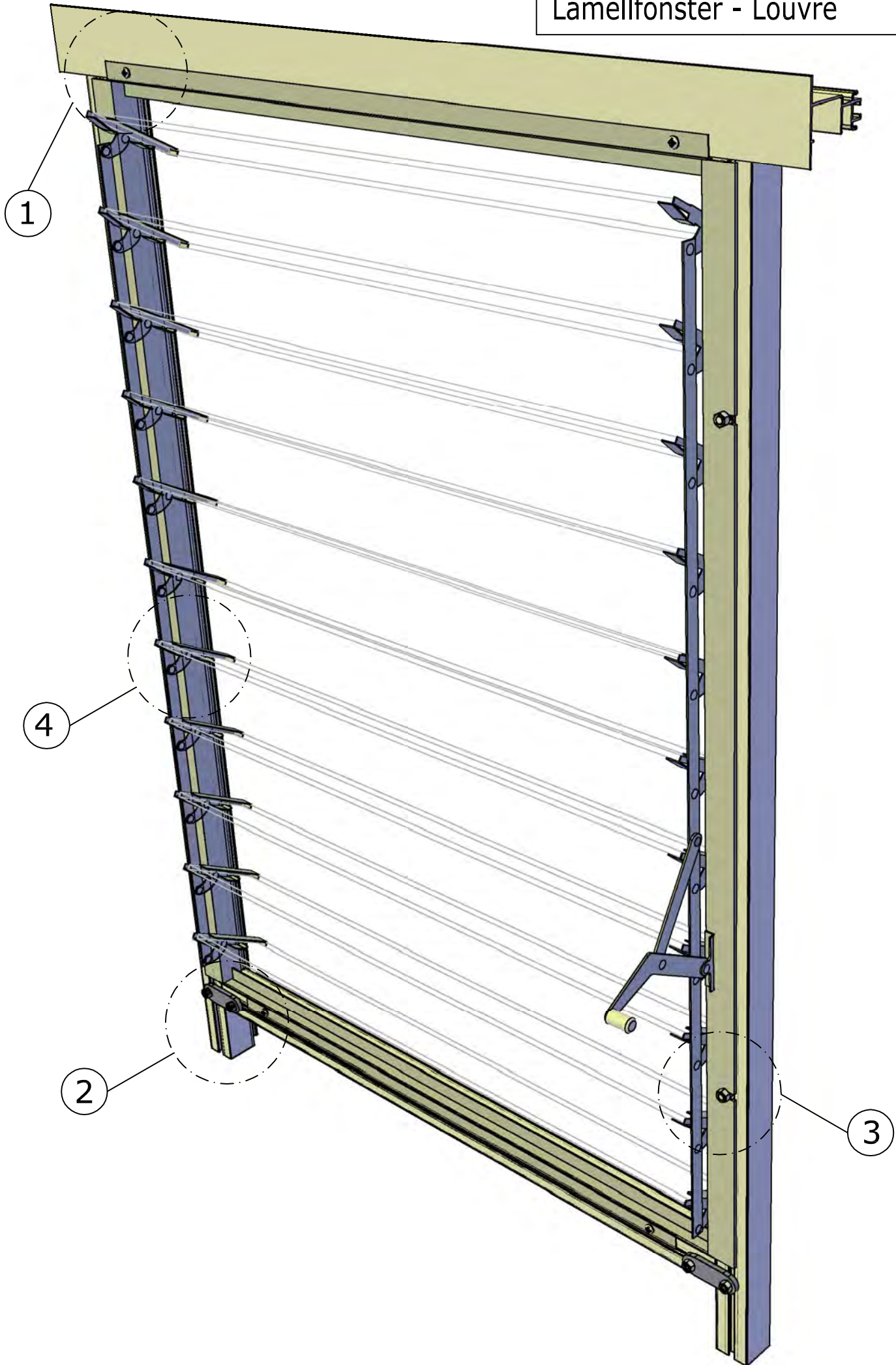

Lammelenraam - Lamellenfenster - Louvre vent - Lamellfenster - Louvre

1

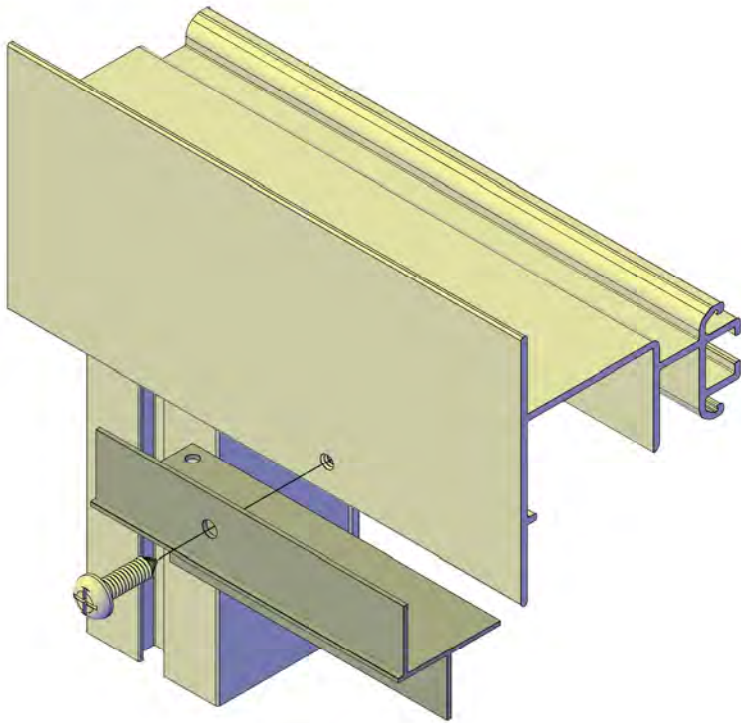

2

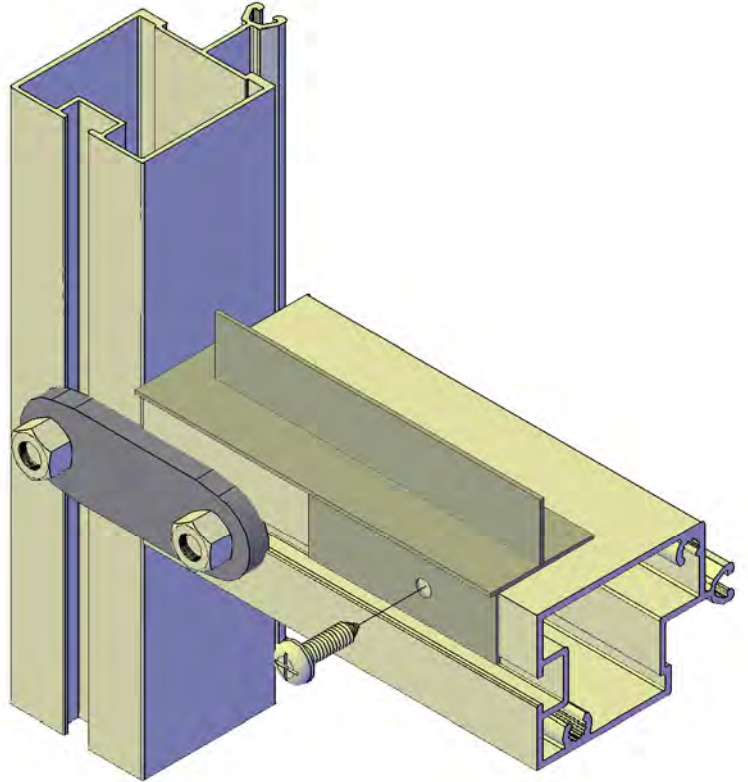

3

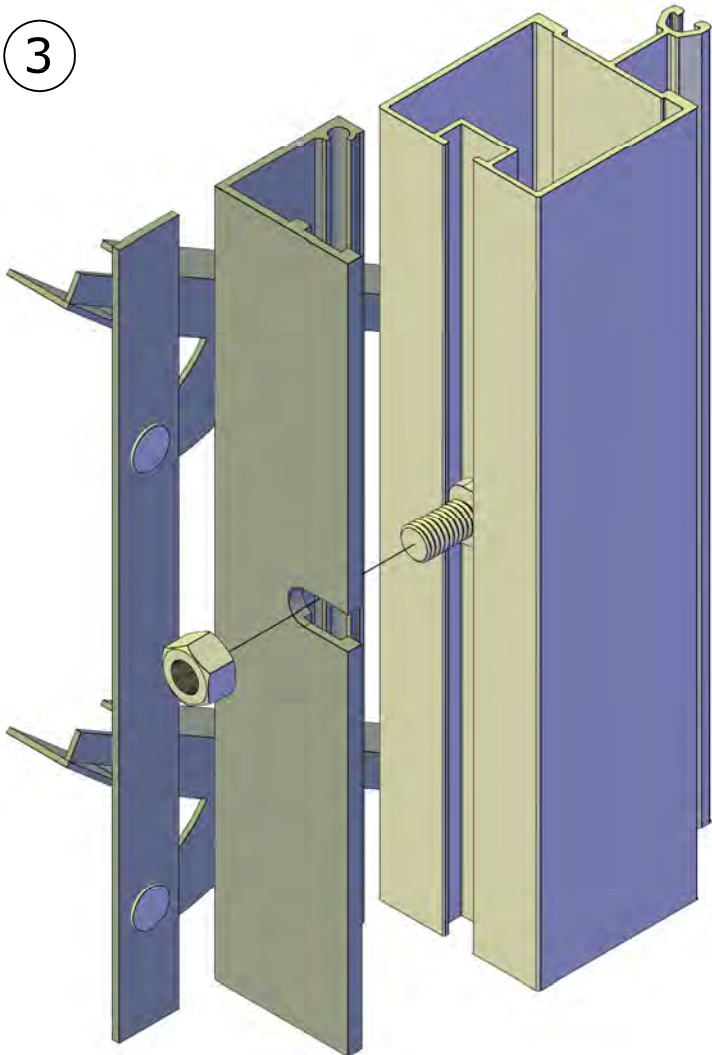

4

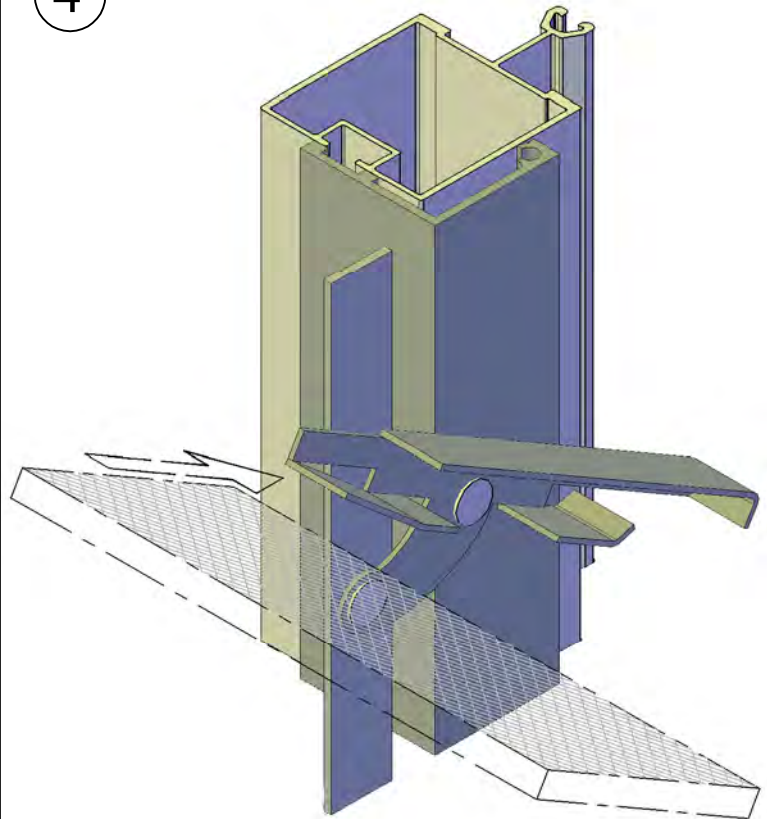

Dakraam-Lucarne-Dachfenster-Roofwindow-Tagvindue
Takluke-Takfönster-Finestra del tetto

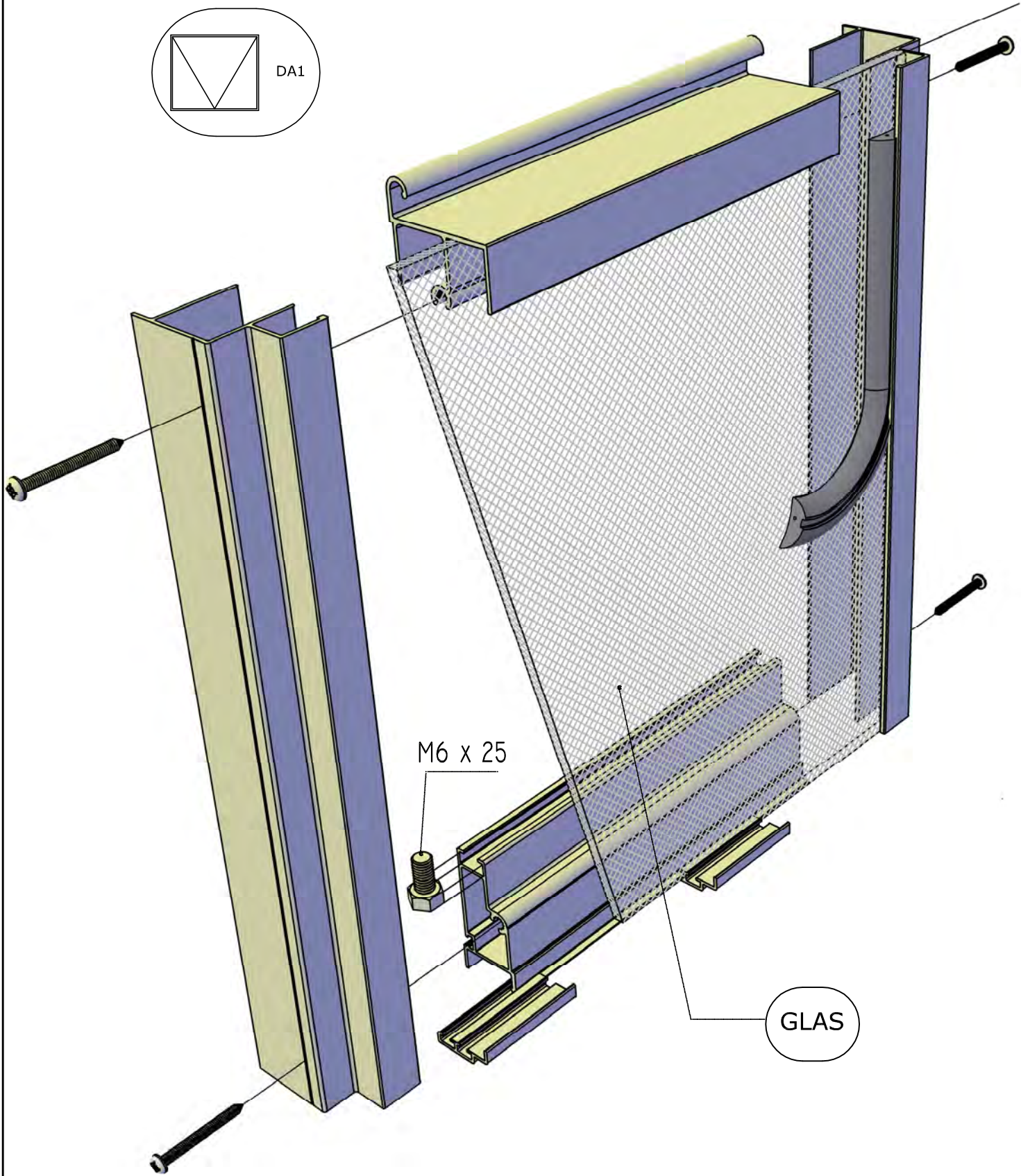

RUBBER E400330

DA1

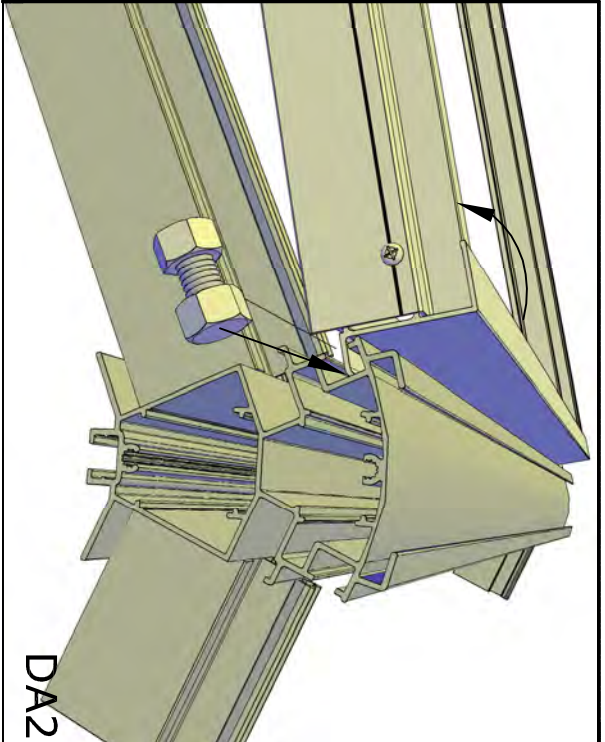
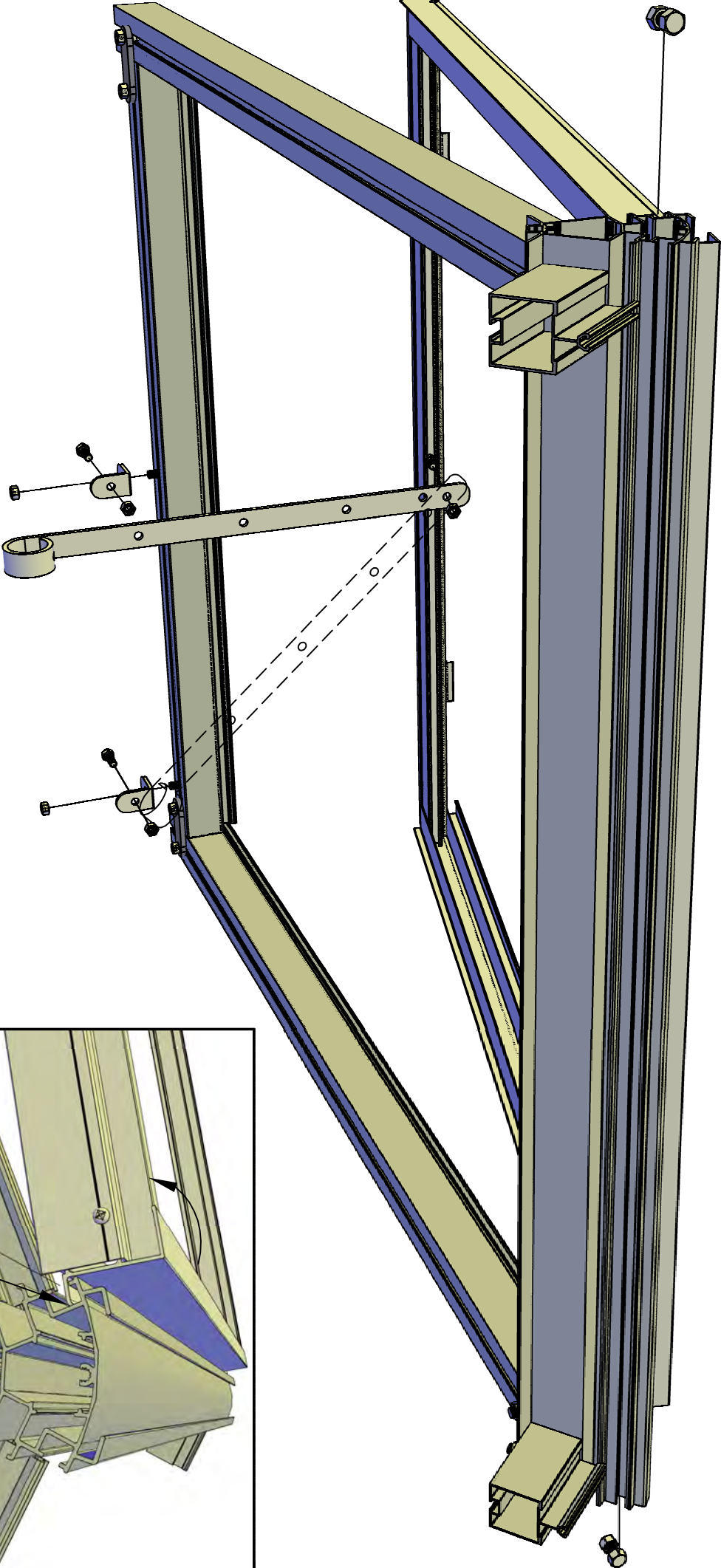

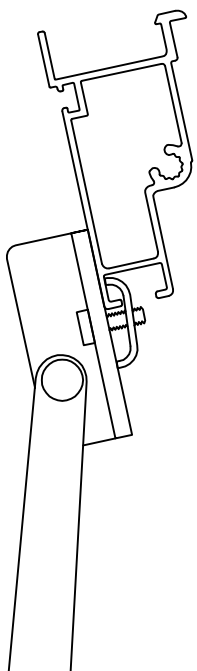
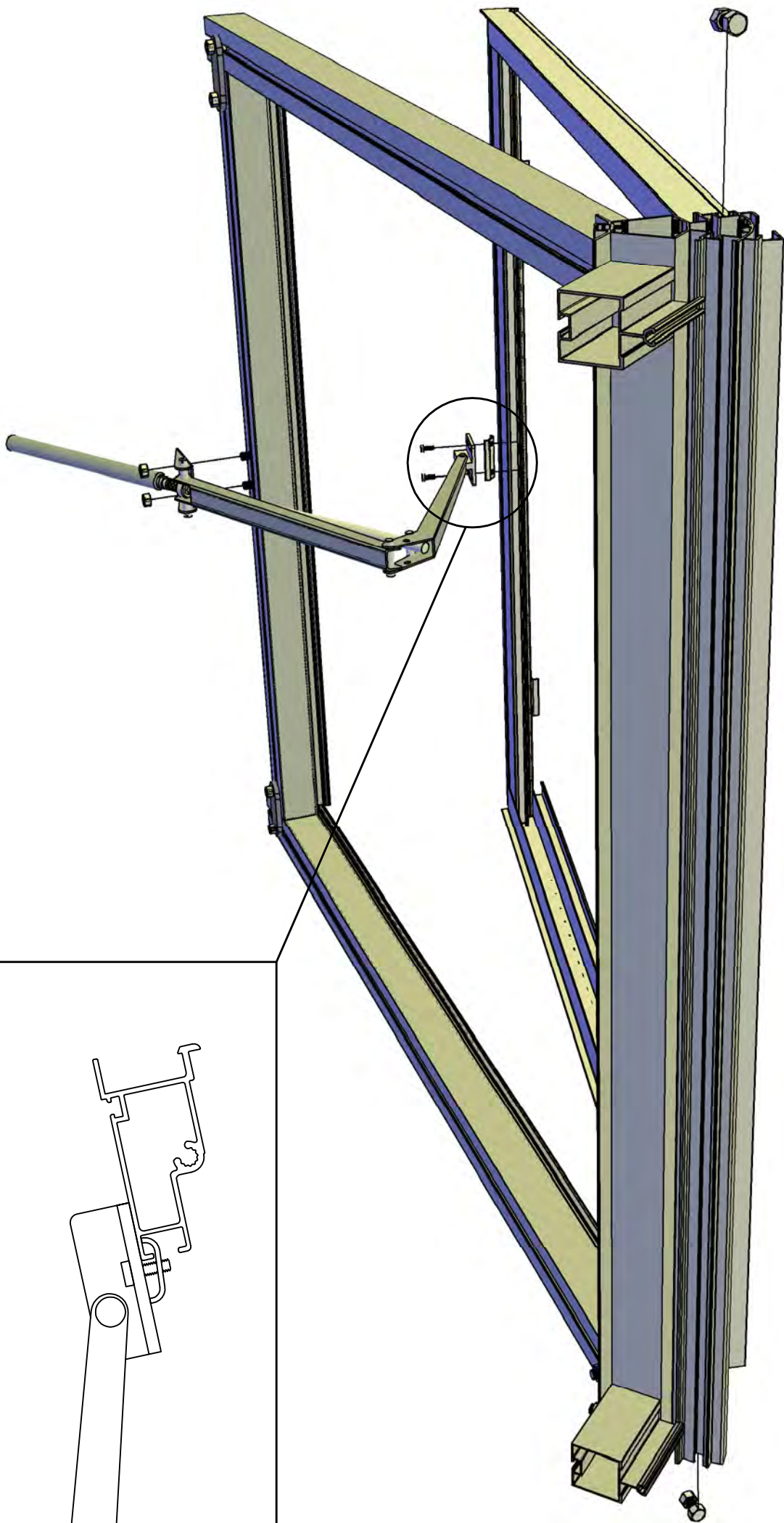

DA2



DA3

Schermdoek - Toile d' ombrage - Strahlenschutz - Sunscreen
 Solskærm-Solskjerm-Telo ombreggiante scorrevole - Skuggväv

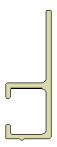
TYPE	800	H23 H33 H43
	160	160
	160	160
	2X L2970	

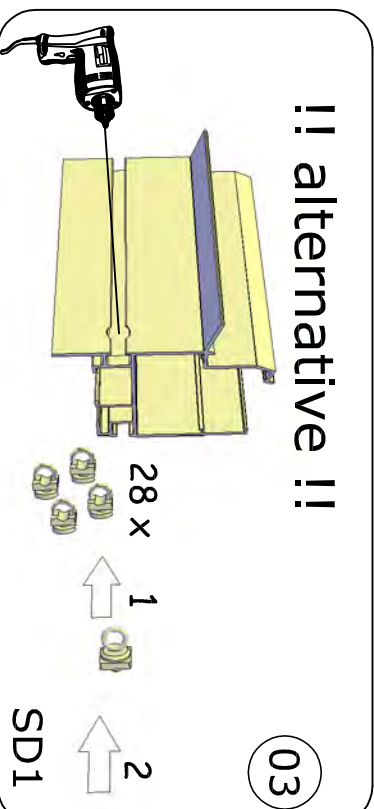
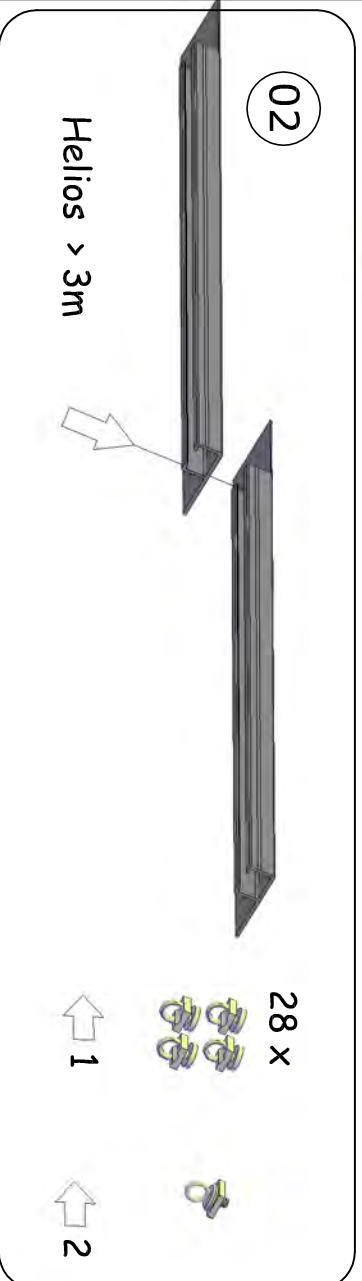
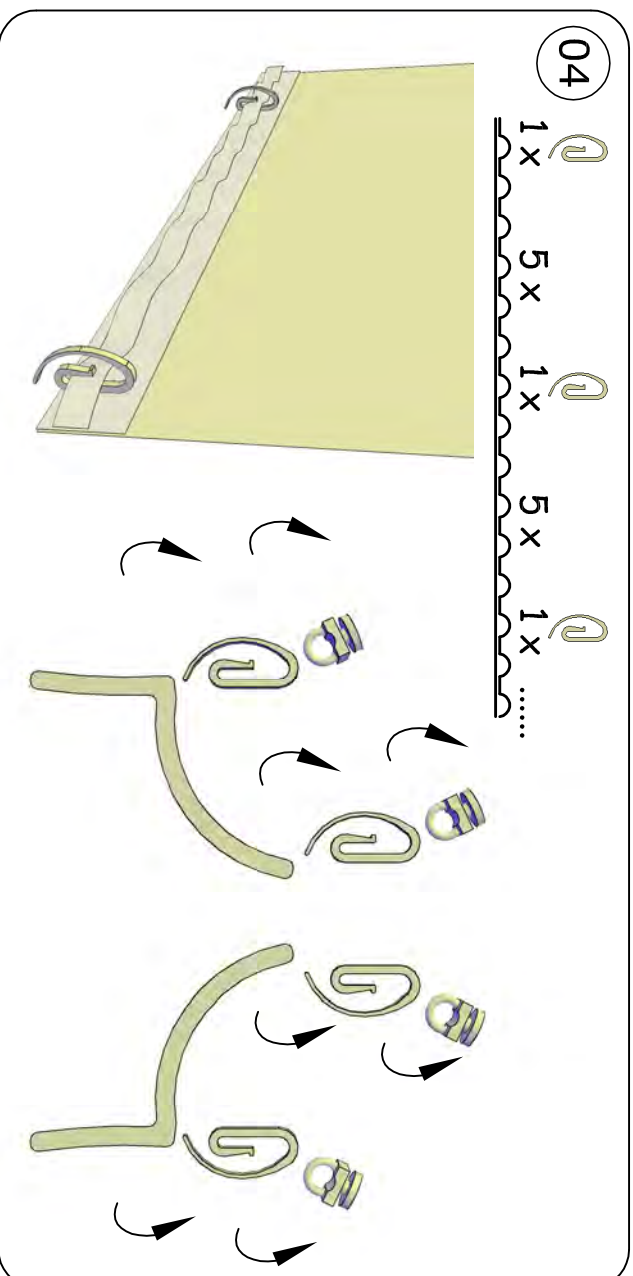
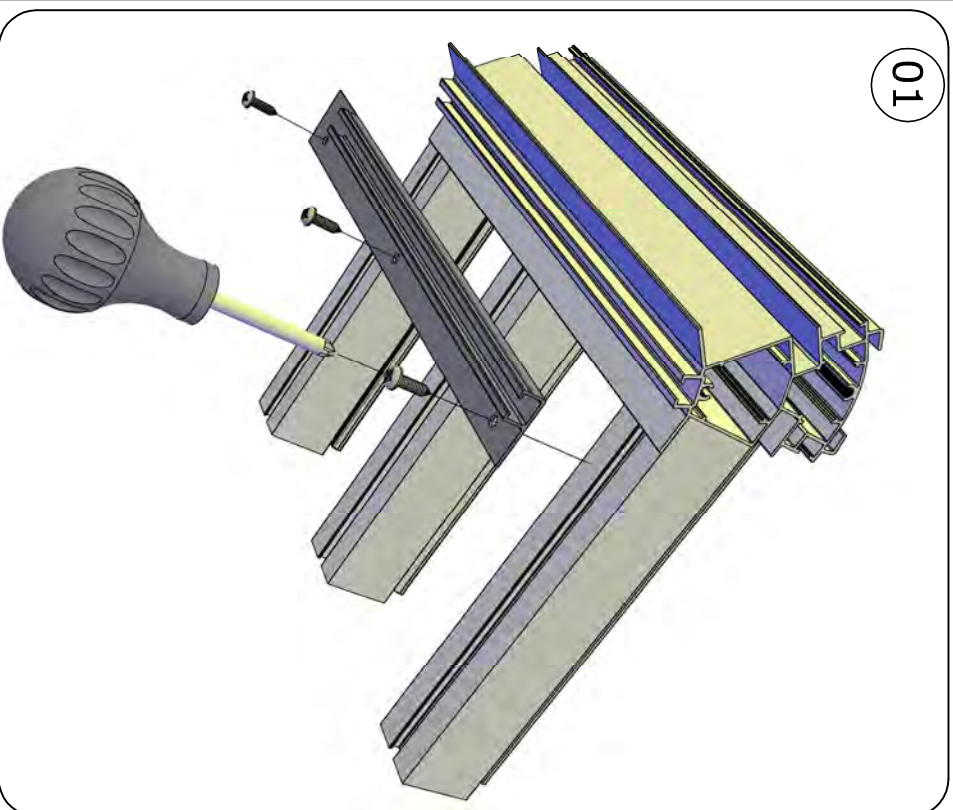

Zaibak-Bac de Culture-Kulturkübel-Seedbed-Blomsterbakke Dyrkningskasse-Såbädd-Bancale da semina

01

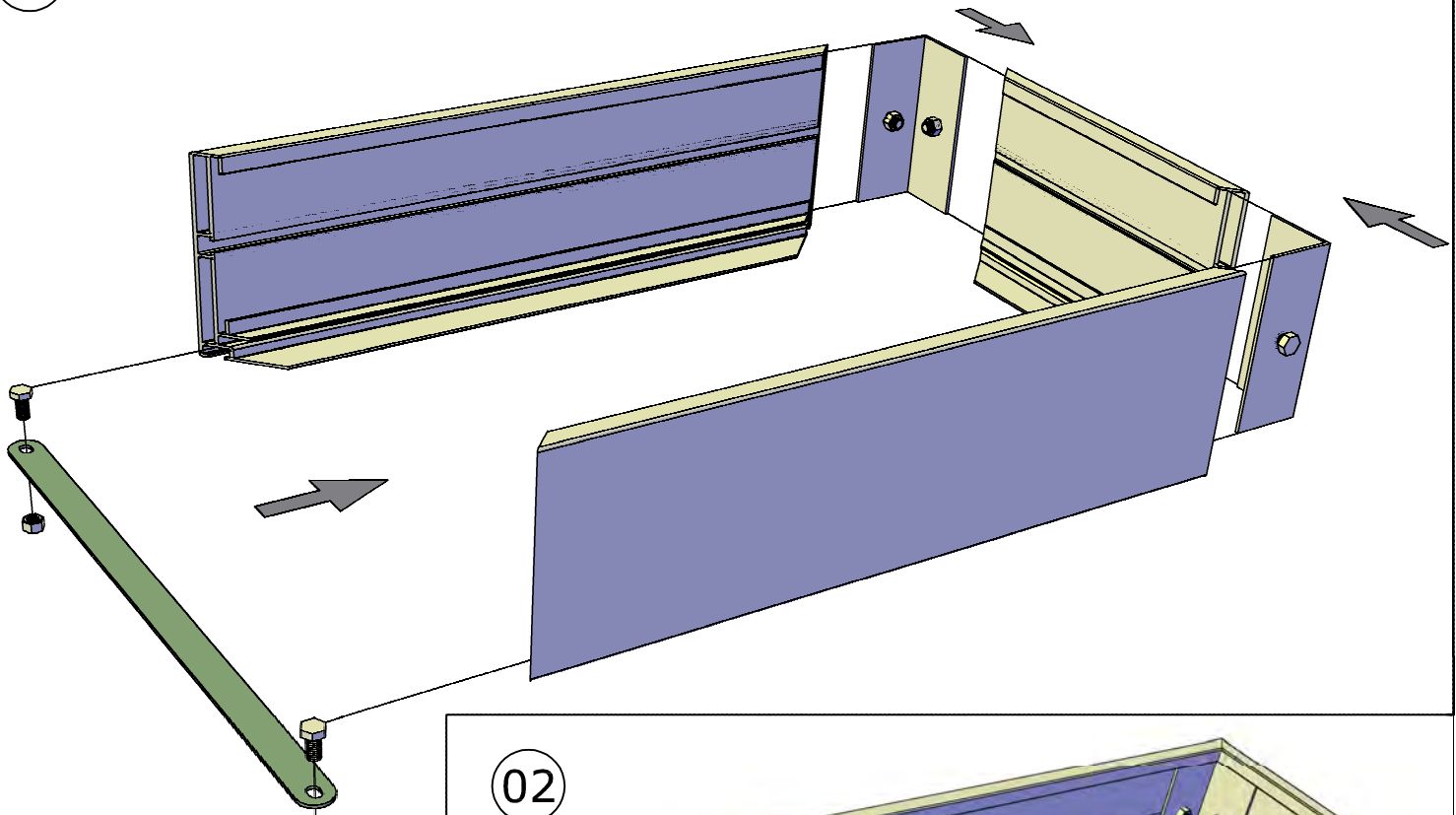

HELIOS
ARCADIA >3,5M

02

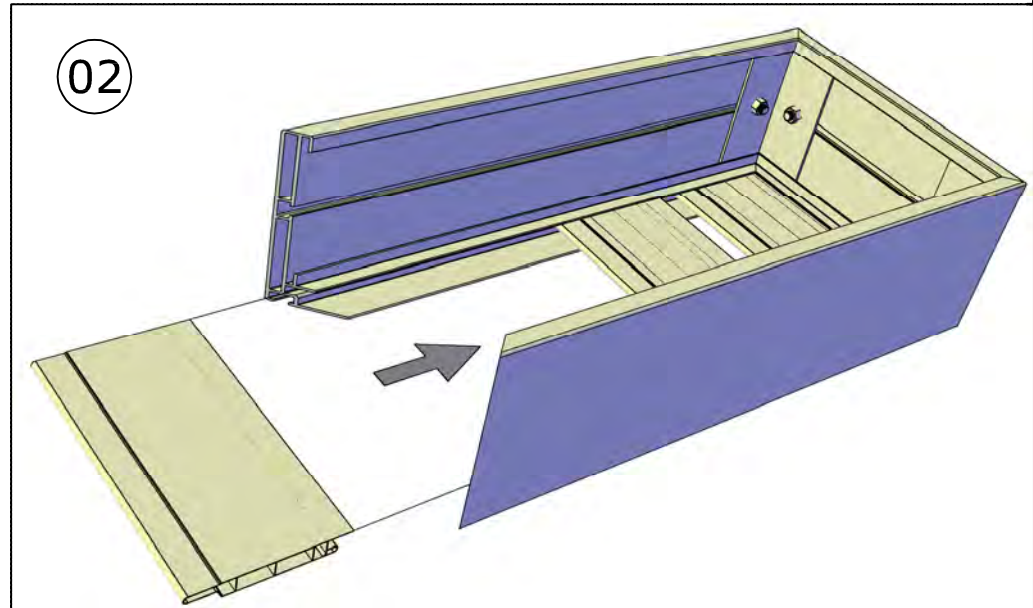

03

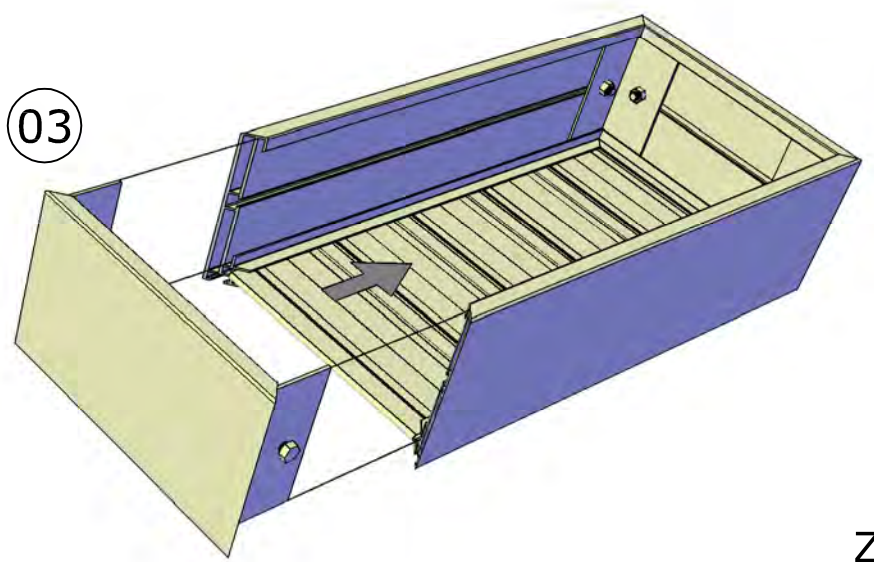

04

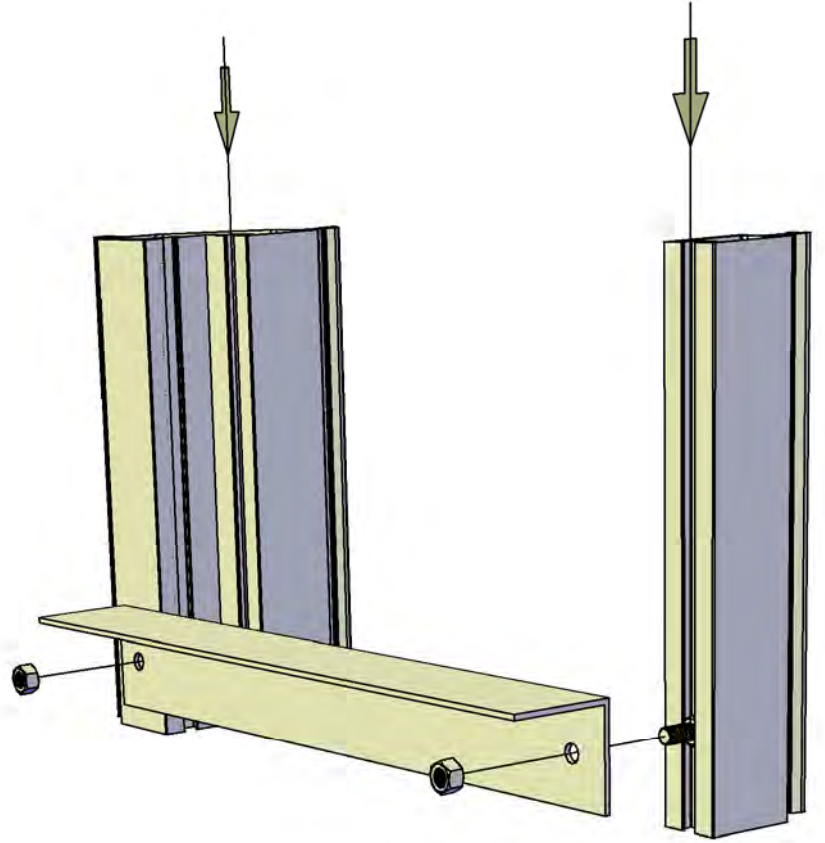

05

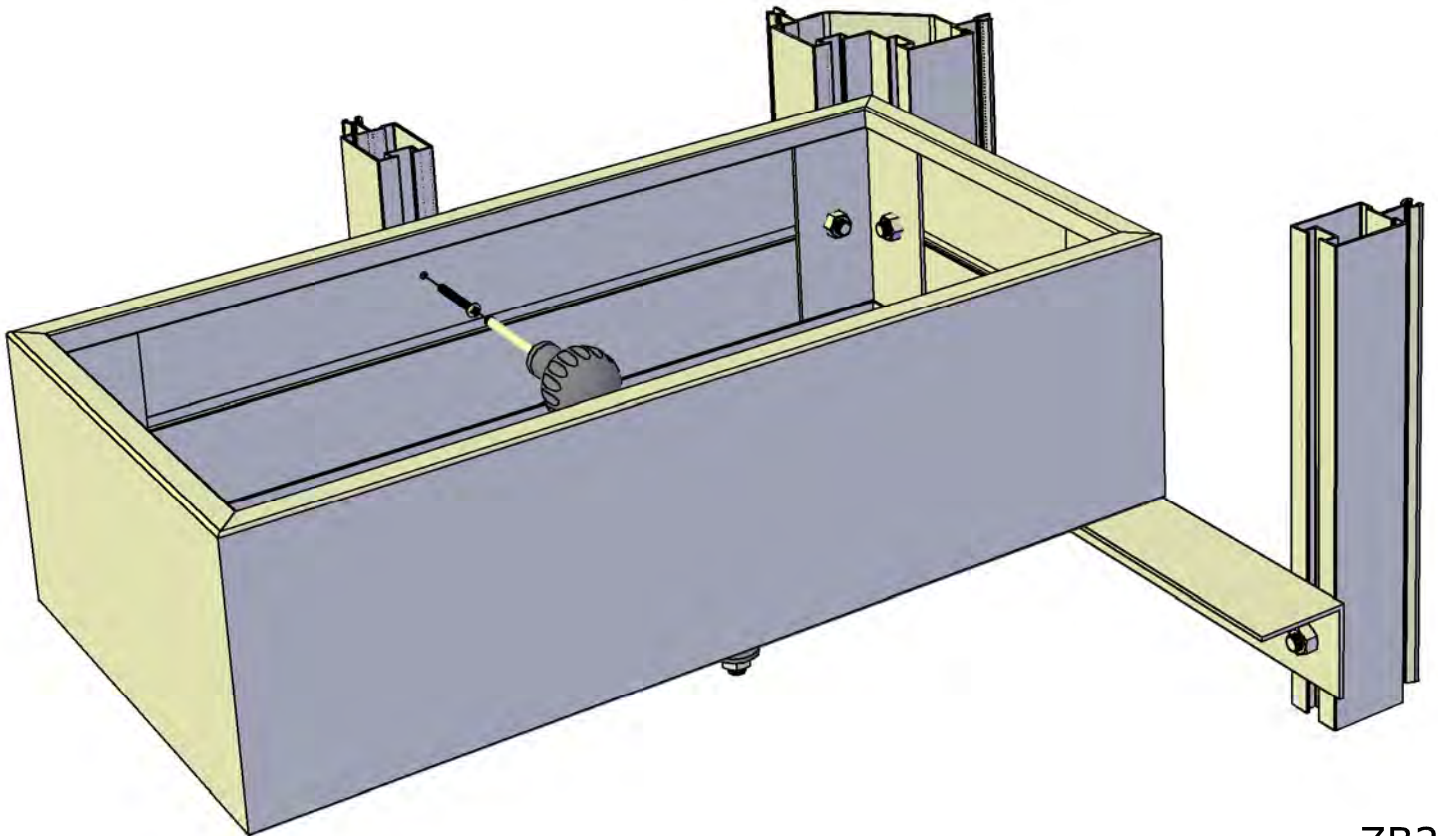

ZB2

Schap - Etapère - Abstellbord - Shelf - Hyide - Hyller - Hyllor - Ripiano di appoggio

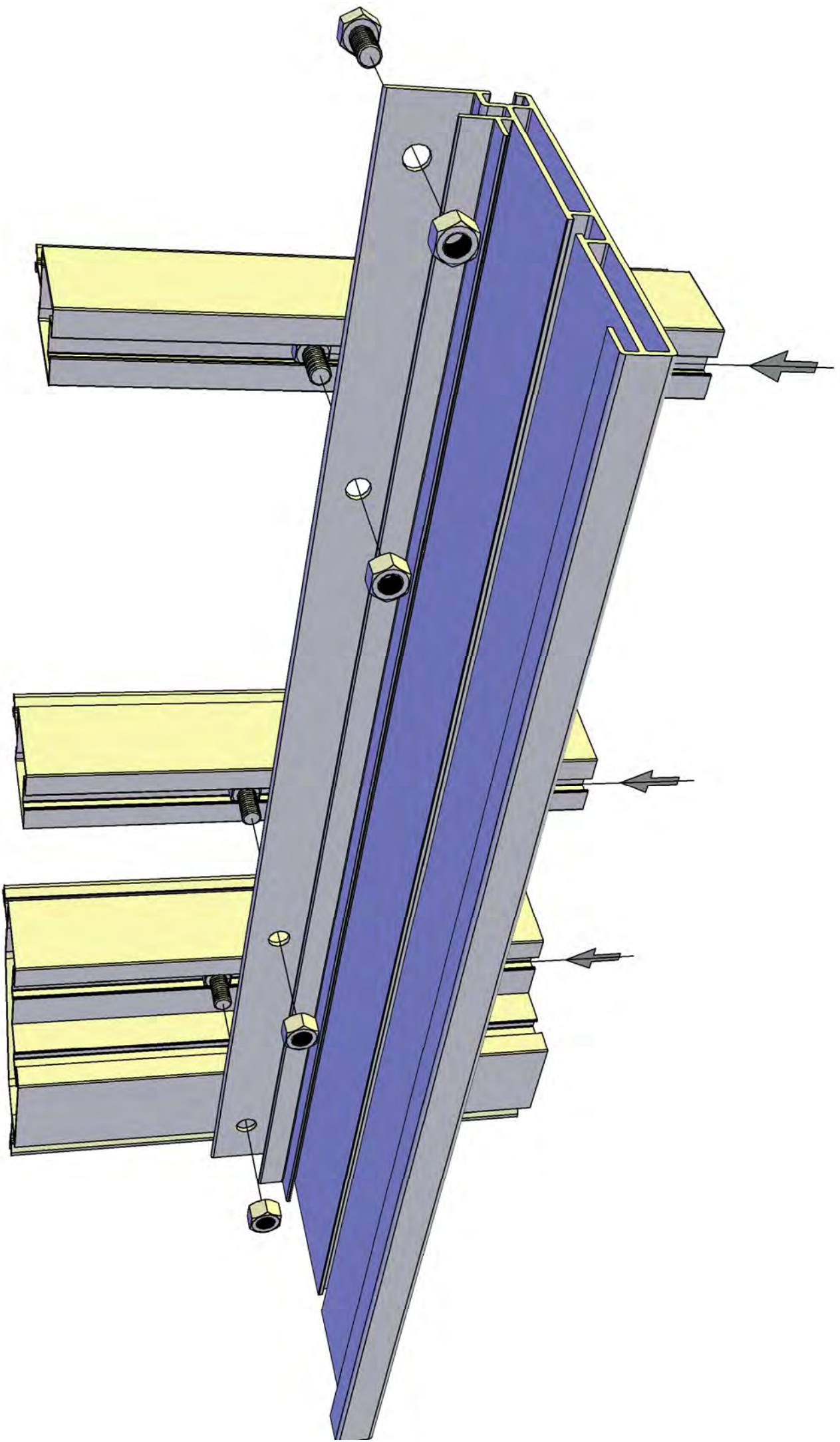

SCI1

Janssens NV Mechelsesteenweg 388, B-2500 Lier Belgium
(T) +32 15 30 67 80 (W) www.janssens-alusystems.be (E) info@janssens-alusystems.be